

The effect of combination lighting of LED and neon light on the growth and yield of potato seeds on the production of Aeroponic seeds in the tropical highland

Eni Sumarni¹, Loekas Soesanto², Widhiatmoko Herry Purnomo³, Priswanto³

(1. Department of Agricultural Technology, Faculty of Agriculture, Jenderal Soedirman University, Purwokerto, Jl. dr. Suparno, Karangwangkal. Postal Code. 53123;

2. Department of Agro-technology, Faculty of Agriculture, Jenderal Soedirman University, Purwokerto, Jl. dr. Suparno, Karangwangkal. Postal Code. 53123;

3. Electrical Engineering Department. Faculty of Engineering. Jl. Mayjen Sungkono Km.05 Blater, Kalimantan, Purbalingga)

Abstract: The lack of solar radiation which reaches potato plants in extreme weather conditions can reduce potato seed production in aeroponic systems. Production of aeroponic potato seedlings in the Indonesian highlands will reduce the number of tubers under conditions of low sunlight. Frequently, misty weather in the highlands inhibits the formation and growth of tubers. In view of this, there is a need to study the addition of the light using different type of lighting and the effect on growth and yield of aeroponic potato seeds. The purpose of this study is to investigate the effect of light addition from LED and neon lights on the growth and yield of potato seeds in an aeroponic system. This study was conducted in a greenhouse at the Banjarnegara Potato Seed Company, Central Java, Indonesia. The research site was at an altitude of 1500 m above sea level. The potato seeds used were Granola variety, produced from tissue culture. The electric conductivity (EC) of nutrition used was 1.8-2 mS cm⁻¹. The nutrition acidity (pH) used was 6. The following lamp types (TL) were investigated: LED1 (12 watts), LED2 (18W), Neon1 (8W), Neon2 (16W), and no additional lighting. A randomized complete block design (RAK) was used with four repetitions. The lamp distance was 90 cm above the surface of the styrofoam. Plant growth parameters that were determined included plant height, number of leaves, number of tubers and tuber weight. Growth data and other results were analyzed by F-test and also with Duncan's Multiple Range Test (DMRT) 5% level. The result of the F-test analysis showed that there was an effect of lamp treatment on plant height, number of leaves, number of tubers, and tuber weight. Plant height with the 18W LED light indicated the greatest plant height response and was not significantly different from plants grown without additional light at 40 and 50 days after planting. The highest number of leaves occurred with the 18W LED light at 50 days after planting. The supply of lighting using 18W LED light has the potential for more high than other types of lights in this research. However, the result of 18W LED lights were inferior to results without additional lighting. Therefore, further research is needed on the lamp power and the height the lamp placed above the plant.

Keywords: Aeroponics, potato seeds, tropical highland, control, LED light, neon lighting

Citation: Sumarni, E., L. Soesanto, W. H. Purnomo, and Priswanto. 2019. The effect of combination lighting of LED and neon light on the growth and yield of potato seeds on the production of Aeroponic seeds in the tropical highland. *Agricultural Engineering International: CIGR Journal*, 21(4): 115–120.

1 Introduction

Cultivation technology for increasing potato seed

production in the wet tropical area begins with aeroponic system (Sumarni et al., 2013a, 2013b, 2013c, 2013d; Sumarni et al., 2016a; Sumarni et al., 2016b; Sumarni et al., 2016c). However, this system is limited by the less than optimal amount of sunlight that reaches the potato in extrem weather condition. If the weather is foggy, the intensity and duration of potato plant exposure to the sun is also reduced which inhibits the formation and growth of tubers. Production of potato seeds in an

Received date: 2018-12-10 **Accepted date:** 2019-07-28

Corresponding author: Eni Sumarni, Ph.D., Associate Professor, Departement of Agricultural Technology, JenderalSoedirman University. Purwokerto. Jl. dr. Suparno. Karangwangkal. Postal Code. 53123. Email: arny0565@gmail.com, Tel: +6281391396079, Fax: (+62281) 638791.

aeroponic system with an average light intensity of ≥ 150 Lux resulted in 25-30 tubers/plant (Sumarni et al., 2016c). In foggy conditions, with < 150 Lux, the number of tubers produced dropped drastically to < 10 tubers/plant (Sumarni et al., 2018). Research on the influence of lamp type on the vegetative growth of aeroponic potato plants in the wet tropical highlands shows that at 40 days after planting the addition of 12W LED lighting gives a better plant growth pattern and higher number of leaves than with a neonlamp.

However, there were many plants that showed etiolation symptoms, so that further research needs to be conducted on the effect of adding light at 50 days after planting and also the effect on potato seed production (Sumarni et al., 2018). Potatoes at the nursery location receive 5-6 hours day^{-1} of light. However, if one day is foggy, the lighting falls below that number of hours and, therefore, reduces tuber production. Potato plants need optimal irradiation, which is 16 hours day^{-1} (Adams and Langton, 2005). Potatoes with irradiation 16 hours day^{-1} will have not susceptible to plant disease (Wijacaksono, 2011). A study of the effect of lamp type on the growth and yield of aeroponic potato seeds is required.

Research on the effect of adding light during the production of several horticultural commodities has been conducted. The addition of light using red, blue, and white LED lights increased can the growth, appearance and quality of lettuce in greenhouse conditions (Lin et al., 2013). The addition of lighting with a lamp that has a blue, yellow, and orange wavelength had a positive impact on the total content of leaf chlorophyll in tomato plants (Kotiranta, 2013). The addition of lighting to the growth of leaf lettuce grown in hydroponic system produced a high growth rate with good photosynthetic activity (Kang et al., 2013). The use of LED light is also able to increase potato growth (Iwanami et al., 1992). However, it is not known how the type of lamp affects the number of potato tubers grown in an aeroponic system in the highlands. Therefore, a study of lighting using a combination of LED and neon lights and investigating the effect on growth and yield in aeroponic potato seed production in the tropical highlands is required. The purpose of this

study is to investigate the effect of adding lighting from LED and neon lights on the growth and yield of aeroponic potato seeds.

2 Materials and methods

This research was conducted in a greenhouse at the Banjarnegara Potato Seed Company, Central Java, Indonesia. The research was conducted at an altitude of 1500 m above sea level from June to September 2018.

2.1 Control of additional lighting

The control system constructed for this research used the following main components: light sensor using a Light Dependent Resistor (LDR), temperature and humidity sensor DHT11, real-time clock (RTC) using DS3231 IC, SD card module for storing data logger, relay module, ULN 2003 IC as a driver circuit, power supply, Arduino Mega 2560 as a controller, and a LCD viewer. The light control circuit with temperature and humidity monitoring, equipped with a data logger, is shown in Figure 1. A flow diagram of the control process is presented in Figures 2 and 3.

The principle of the circuit is the LDR light sensor converts the measurement of light intensity into an electrical signal. The Arduino controller via the Analog Pin A1 then reads the electrical signal in the form of an analog voltage. Then, the Arduino controller converts the analog voltage signal to digital voltage data as an indicator of light intensity. The digital voltage data are then converted into units of lux light intensity.

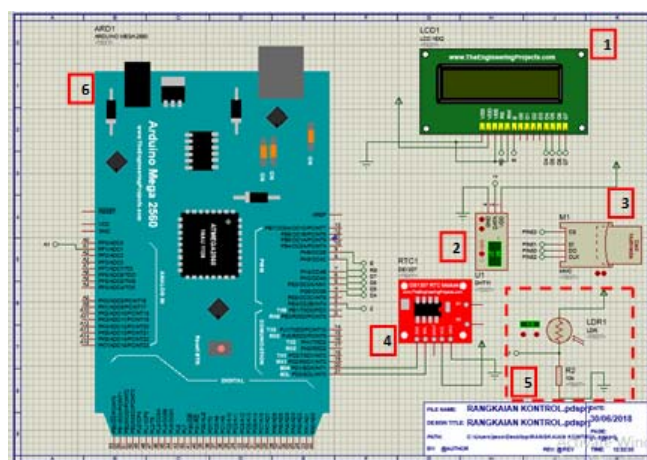

1. LCD viewer 2. DHT11 sensor 3. SD card module 4. RTC DS1307 / 3231 5. LDR sensor circuit 6. Arduino Mega 2560

Figure 1 Light control circuit with temperature and humidity data logger

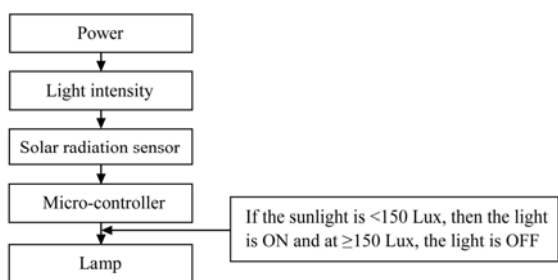

Figure 2 Flow diagram sensor for adding light

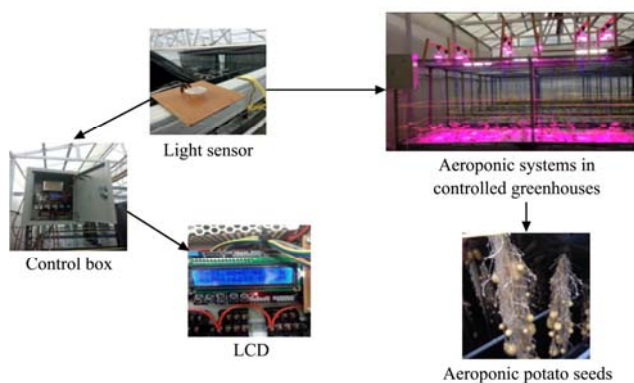

Figure 3 Sensor layout for adding light in the greenhouse

Intensity data in the form of lux, then compared with the set point that to control by the ON or OFF. The ON or OFF light control was controlled via the Arduino pin output Number 30, 31, 32, 33 which was connected to the relay driver. The relay regulated the connection between the AC 220V lamp load and the 220V AC power supply for the lamp. In this study, the lower limit of light

intensity that turned the light ON was set at <150 Lux, while the upper limit of the light intensity to deactivate the lamp was set at ≥ 150 Lux. The controller also switched the lamp ON or OFF based on time, that is the lamp was automatically turned OFF at 10:00 p.m. until 6:00 p.m., whereas outside that period the light was set based on the reading of the light intensity according to the set point.

2.2 Experimental design and analytical data

Granola seed potatoes were used in the study, grown by tissue culture. The Electric Conductivity of nutrient solution (EC) used was $1.8-2 \text{ mS cm}^{-1}$. The acidity of nutrient solution (pH) used was 6. The following lamp types (TL) were investigated (LT): LED1 (12W), LED2 (18W), Neon1 (8W), Neon2 (16W), and without additional lighting. A randomized complete block design (RCBD) was used with four repetitions. The lamp was positioned 90 cm above the surface of the styrofoam. Plant growth parameters observed included plant height, number of leaves, number of tubers and tuber weight. Growth data and other results were analyzed using the F-test, followed by Duncan’s Multiple Range Test (DMRT) with a 5% probability level. The picture of light layout of the data retrieval is presented in Figure 4.

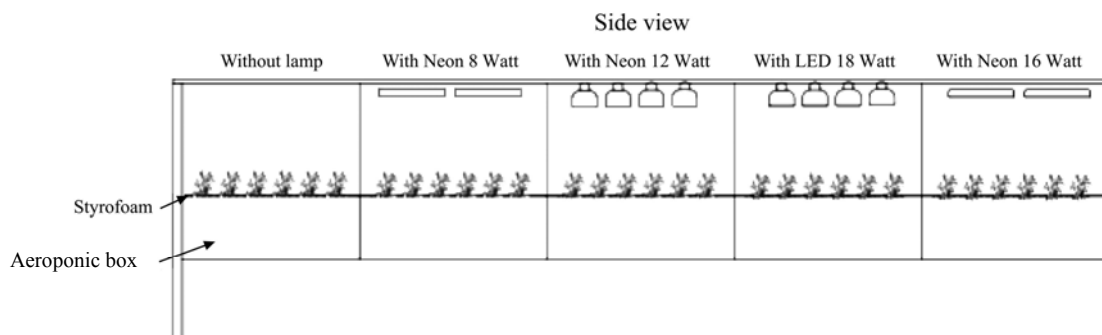

Figure 4 Light layout on data retrieval in the greenhouse

3 Results and discussion

3.1 Micro-climate in the greenhouse

3.1.1 Intensity of light in the greenhouse

Micro-climate conditions in the greenhouse used for potato seed production, such as monthly light intensity during data retrieval, are presented in Figure 5. Light intensity in June reached 900 Lux, 980 Lux in July and 1009 Lux in August. Misty conditions often occurred at the location, which are less than optimal for the growth of potato plants. Potato plants, according to Otroshy (2006),

include short-day crops and C3 plants which have a low tendency for light saturation. This allowed the addition of light using LED or Neon lamps.

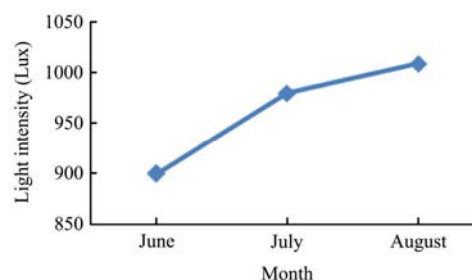

Figure 5 Light intensity in the greenhouse during the experiment

3.1.2 Air temperature and humidity in the greenhouse

The average air temperature in the greenhouse used for aeroponic potato seed production ranged from 9.7°C to 13.7°C. Air humidity was 85%-90% (Figure 6). The air temperature during the growth of the potato plants was low. Optimal air temperature for the development of potato tubers is around 15°C-20°C (Rykaczewska, 1993; Van Dam *et al.*, 1996). The low temperature conditions in the research greenhouse were triggered by snowfall near the location.

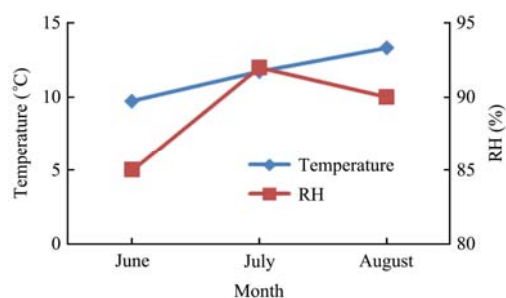

Figure 6 Air temperature and humidity during the experiment

3.2 Effect of lamp type on plant growth

The result of the F-test analysis shows that there was an effect of lamp treatment on the variables of plant height, number of leaves, number of tubers and tuber weight. The plant height with the 18W LED lighting showed the biggest response and was not significantly different from plant height without light at 40 and 50 days after planting. The greatest plant height occurred with 18W LED lighting at 50 days after planting (Table 1).

Table 1 The effect of lamp type on plant height

Treatment	Plant height (cm)		
	30 Days after planting	40 Days after planting	50 Days after planting
Without lamp	27.50a	29.93a	32.60a
Neon 8W	17.85c	21.18b	24.18c
LED 12W	17.98c	22.23b	25.50bc
LED 18W	24.40b	27.48a	31.45a
Neon 16W	18.50c	23.40b	26.78b

Note: Numbers which are followed by the same letter are not significantly different in DMRT at the 5% level.

The greatest plant height occurred in plants without additional light (32.60 cm) and with 18W LED lights (31.45 cm). LED light can be an alternative to additional lighting during the vegetative period in aeroponic potato plants. This is consistent with some of the results of research on LED lights which were able to increase bud assimilation in cropped roses (Harada and Komagata, 2014). Blue red LED lights also produced fast growth in

chrysanthemum plants compared to other types of lights (Syafriyudin and Ledhe, 2015). Based on previous research absorption of the blue and red light from LED lights gives 90% influence on plant development and physiological process (Frechilla *et al.*, 2000; Terashima *et al.*, 2009).

The development of the number of leaves, also shows that 18W LED lamps (31.23 sheets of leaves) gives an increase in the number of leaves from 30 days after planting to 50 days after planting is the highest and followed by no light (26.93 sheets of leaves) (Table 2). Characteristics of the LED light used at 18W has 14 red-colored composition with a wavelength of 640-670 nm and 4 in blue colored with a wavelength of 450-470 nm. Results of research on the use of LED lighting chrysanthemum plants show that the additional lighting using blue and red LED lights produced rapid growth (Syafriyudin and Ledhe, 2015).

Table 2 Effect of lamp type on number of leaves

Treatment	Number of leaves (sheet)		
	30 Days after planting	40 Days after planting	50 Days after planting
Without lamp	16.48b	23.65a	26.93b
Neon 8W	11.28c	17.10d	21.80c
LED 12W	14.60c	21.85b	23.38c
LED 18W	17.68a	24.85a	31.23a
Neon 16W	13.25d	19.68c	23.40c

Note: Numbers which are followed by the same letter are not significantly different in DMRT at the 5% level.

Red LED lights consist of several materials, namely aluminum gallium arsenide (AlGaAs), gallium arsenide phosphide (GaAsP), aluminum gallium indium phosphide (AlGaInP), and gallium (III) phosphide (GaP). Red color contributes well to plant growth. This is because chlorophyll absorbs red light during photosynthesis, so that the length and shape of the leaves are ideal. Blue LEDs have several constituent materials, such as zinc selenide (ZnSe) and indium gallium nitride (InGaN). Blue LED lights are also good for photosynthesis. The development of the use of LED lights for additional lighting is reported to have a strategic position to manipulate lighting in the framework of plant growth and development compared to conventional electrical light sources (Morrow, 2008; Massa *et al.*, 2008; Folta and Childers, 2008; Stutte, 2009; Adams and Langton, 2005). This can be a challenge to overcome the foggy conditions

in the highlands. From the research of this type of lamp in the production of potato seeds in tropical highlands, 30% of plants showed symptoms of etiolation, indicating that additional lighting is needed (Sumarni et al., 2018).

3.3 Type of light to the number of tuber and tuber weight

The effect of the lamp type on potato seed production in terms of the number of tubers and tuber weight showed differences. The 18W LED produced the highest number of tubers (18.8 pieces) compared to the other types of lamp, but tuber production was higher without using a lamp (22.0 pieces). Likewise with tuber weight, the 18W LED light (6.5 g) produced a higher yield than the other types of lamps, but yield was higher without using light (16.5 g) (Table 3).

Table 3 Effect of types of lamps on the number of tubers and tuber weight

Treatment	Number of tubers (pieces)	Tuber weight (g)
Without lamp	22.0a	16.5a
Neon 8W	5.8d	3.8c
LED 12W	13.8c	4.0c
LED 18W	18.8b	6.5b
Neon 16W	6.0d	4.5c

Note: Numbers which are followed by the same letter are not significantly different in DMRT at the 5% level.

The addition of LED artificial light has a higher yield compared to other lamp types in this study. However, the results for 18W LED lighting are still poorer than results without lights. Therefore, further study on lamp power and the height that it is placed above the plant is needed.

4 Conclusions

The result of the F-test analysis showed that there was an effect of lamp treatment on plant height, number of leaves, number of tubers, and tuber weight. Plant height with the 18W LED light indicated the greatest plant height response and was not significantly different from plants grown without additional light at 40 and 50 days after planting. The highest number of leaves occurred with the 18W LED light at 50 days after planting. The supply of lighting using 18W LED light has the potential for more high than other types of lights in this research. However, the result of 18W LED lights were inferior to results without additional lighting. Therefore, further research is needed on the lamp power and the height the lamp placed above the plant.

Acknowledgement

We thank Jenderal Soedirman University for the funding provided in 2018 (no. 3781/UN2314/PN/2018) that enable thus research to be conducted.

References

- Adams, S., and A. Langton. 2005. Photo period and plant growth: journal of horticultural. *Science and Biotechnology*, 80(1): 2–10.
- Folta, K. M., and K. S. Childers. 2008. Light as a growth regulator: controlling plant biology with narrow-bandwidth solid-state lighting systems. *Horticultural Science*, 43(7): 1957–64.
- Frechilla, S., L. D. Talbott, R. A. Bogomolni, and E. Zeiger. 2000. Reversal of blue light-stimulated stomatal opening by green light. *Plant Physiology*, 41(2): 71–176.
- Harada, T., and T. Komagata. 2014. Effects of long-day treatment using fluorescent lamps and supplemental lighting using white LEDs on the yield of cut rose flowers. *Japan Agricultural Research Quarterly*, 48(4): 443–448.
- Iwanami, Y., T. Kozai, Y. Kitaya, and S. Kino. 1992. Effects of supplemental red and far-red lighting using light emitting diode on stem elongation and growth of potato plantlets in vitro. In *International Symposium Transplant Production Systems*, pp.183. Yokohama, Japan, 21-26 July (abstr).
- Kang, J. H., S. K. Kuma, S. L. S. Atulba, B. R. Jeong, and S. J. Hwang. 2013. Light intensity and photoperiod influence the growth and development of hydroponically grown leaf lettuce in a closed-type plant factory system. *Horticulture, Environment and Biotechnology*, 54(6): 501–509.
- Kotiranta, S. 2013. The effect of light quality on tomato (*Solanum Lycopersicum* L. Cv Efialto) growth and drought tolerance. M.S. thesis, Helsinki: University of Helsinki, Department of Agricultural Sciences Horticulture.
- Lin, H., M. Huang, W. Huang, M. Hsu, Z. Yang, and C. Yang. 2013. The effects of red, blue, and white light-emitting diodes on the growth, development, and edible quality of hydroponically grown lettuce (*Lactuca sativa* L. var. capitata). *Scientia Horticulturae*, 150(2): 86–91.
- Massa, G. D., H. H. Kim, R. M. Wheeler, and C. A. Mitchell. 2008. Plant productivity in response to LED lighting. *HortScience*, 43(7): 1951–1956.
- Morrow, R. C. 2008. LED lighting in horticulture. *HortScience*, 43(7): 1947–1950.
- Otroshy, M. 2006. Utilization of tissue culture techniques in a seed potato tuber production scheme. Ph.D. diss., Netherlands: Wageningen University.
- Rykaczewska, K. 1993. Effect of temperature during growing season and physiological age of minitubers on potato plant development and yield. *Bulletin of the Potato Institute*, 42(1):

- 39–46.
- Stutte, G. W. 2009. Light-emitting Diodes for manipulating the phytochrome apparatus. *HortScience*, 44(2): 231–234.
- Sumarni, E., S. Herry, B. S. Kudang, and dan S. K. Saptomo. 2013a. Aplikasi pendinginan zona perakaran (*root zone cooling*) pada produksi benih kentang menggunakan sistem aeroponik. *Indonesian Journal of Agronomy*, 41(2): 154–159.
- Sumarni, E., S. Herry, B. S. Kudang, and dan S. K. Saptomo. 2013b. Perpindahan panas pada aeroponik chamber dengan aplikasi zone cooling. *Jurnal Biofisika*, 9(1): 8–19.
- Sumarni, E., G. H. Sumartono, and dan S. K. Saptomo. 2013c. Aplikasi zone cooling pada sistem aeroponik kentang di dataranmedium tropika basah. *Jurnal Keteknik Pertanian*, 1(1): 99–106.
- Sumarni, E., S. Herry, and dan S. K. Saptomo. 2013d. Seed potato production using aeroponics system with zone cooling in wet tropical lowlands. *ISHS Acta Horticulturae 1011: II Asia Pacific Symp. on Postharvest Research, Education and Extension*, 1011. Yogyakarta, 18-20 September. DOI: 10.17660/ActaHortic.2013.1011.16.
- Sumarni, E., N. Farid, A. N. Sugiarto, and A. Sudarmadji. 2016a. Go seed potentia lof the aeroponics potatoes seed in the lowlands with a root zone cooling into G1 in the highlands. *Rona Teknik Pertanian*, 9(1): 1–10.
- Sumarni, E., N. Farid, and Darjanto. 2016b. Pengembangan produksi benih kentangdataran rendah dengan aeroponik sistem *root zone cooling* dan biopestisida serta pemanfaatan listrik energi surya. Universitas Jenderal Soedirman. Purwokerto: Laporan Penelitian Hibah Strategis Nasional.
- Sumarni, E., N. Farid, Suwanto, and L. Susanto. 2016c. Diseminasi teknologi aeroponik di dataran tinggi Banjarnegara. Universitas Jenderal Soedirman. Purwokerto. Jawa Tengah.
- Sumarni, E., L. Soesanto, and W. H. Purnomo. 2018. Pengaruh jenis lampu pada aplikasi kontrol ptotoperiodic terhadap pertumbuhan vegetatif tanaman kentang aeroponik di dataran tinggi tropika basah. *Proceeding In Seminar Nasional PERTETA*, pp: 270–274. Yogyakarta, 29-30 Agustus. ISBN : 978-602-51151-6-5.
- Syafriyudin, N., and T. Ledhe. 2015. Analisis pertumbuhan tanaman krisan pada variabel warna cahaya lampu LED. *Jurnal Teknologi*, 8(1): 83–87.
- Terashima, I., T. Fujita, T. Inoue, W. S. Chow, and R. Oguchi. 2009. Green light drives leaf photosynthesis more efficiently than red light in strong white light: Revisiting the enigmatic question of why leaves are green. *Plant and Cell Physiology*, 50(4): 684–697.
- Van Dam, J., P. L. Kooman, and P. C. Struik. 1996. Effects of temperature and photoperiod on early growth and final number of tubers in potato (*Solanum tuberosum* L). *Potato Research*, 39(1): 51–62.
- Wijacaksono, A. 2011. *Respon Pertumbuhan Tanaman Kentang (Solanum Tuberosum L.) Varietas Atlantis Dalam System Aeroponik Terhadap Periode Pencahayaan*. Bogor: FMIPA IPB.