

Presence and dimensional assessment of power take-off (PTO) protection of new Brazilian agricultural tractors

Sabrina Dalla Corte Bellochio^{*}, Airton dos Santos Alonço, Gessieli Possebom, Patrícia Gubiani, Lutiane Pagliarin

(Agricultural Engineering Post Graduation Program, Rural Engineering Department, Federal University of Santa Maria, Santa Maria, Rio Grande do Sul State, Brazil)

Abstract: Contact with tractor moving parts is one of the most frequent causes of accidents with agricultural machinery. Thus, the present study aims to verify the presence of power take-off (PTO) master shield and its dimensional specification, in new Brazilian agricultural tractors, according to ABNT NBR ISO 500-1 (2016) standard. We evaluated 43 agricultural wheeled tractors models, with power above 36.8 kW, distributed in seven dealers located in Santa Maria, RS. Data collection was based on the visual verification of the presence or absence of PTO master shield (BRASIL, 2013), as well as its dimensional variables verified through the use of measuring tape. Regarding the presence, 100% of the analyzed models contained the PTO master shield. Regarding the PTO master shield dimensions, tractor models classified as PTO type 2 or 3, fulfilled 100% of the current standard, however, considering PTO type 1, 79.31% showed total compliance. Regarding to the tractor manufacturers brands, four out of seven was totally non-compliant, two brands was non-compliant in most of the dimensional variables studied and only the brand “D” was 100% compliant in all variables analyzed. Thus, the most agricultural tractors manufacturers studied are placing on the Brazilian market tractors who are not totally compliant with PTO master shield standard, which may favor the occurrence of accidents.

Keywords: agricultural mechanization, safety, compliance, moving parts, accidents

Citation: Bellochio, S. D. C., A. D. S. Alonço, G. Possebom, P. Gubiani and L. Pagliarin. 2019. Presence and dimensional assessment of power take-off (PTO) protection of new Brazilian agricultural tractors. *Agricultural Engineering International: CIGR Journal*, 21(3): –.

1 Introduction

The agriculture evolution has opened channels for the expansion of agricultural frontiers. In Brazil, the increase in modernization and agricultural production began to show significant results in the twentieth century, more precisely during the 1960s and 1970s in the period known as the Green Revolution (Vian et al., 2013; Gerhard, 2016; Gonçalves, 2017). At this time, there was a growing stimulus to the development of mechanization, intensifying the production of agricultural tractors, which have the purpose of transporting, traction and supplying

power for implements, which facilitates the accomplishment of activities in rural areas (Schlosser, 2001; Rinaldi et al., 2016).

From the use of tractors, Madeira (2011) considered that there was an improvement in working conditions, experienced by workers in the agricultural environment, contributing to the minimization of physical efforts. However, it is possible to observe that this equipment is involved in the majority of the accidents that occur in the agricultural environment (Fernandes et al., 2014; Corrêa et al., 2016; Alçayir and Haciseferoğullari, 2017; Cividino et al., 2018). The contact with the cardan shaft was responsible for 37.5%, 29.82% and 20.9% of the accidents occurrences with agricultural tractors, respectively to studies by Monteiro (2010), Fernandes et al. (2014) and Alçayir and Haciseferoğullari (2017).

According to the data obtained by Lubicky and

Received date: 2018-10-04 **Accepted date:** 2018-12-12

*** Corresponding author: Sabrina Dalla Corte Bellochio,** Agricultural Engineering Post Graduation Program, Rural Engineering Department, Federal University of Santa Maria. Tel +55 55 3220 8158, Email:bellochiosabrinad@hotmail.com.

Feinberg (2009), in the analysis of the index of fractures and amputations in children and adolescents after accidents in USA rural properties, the agricultural tractor was the machine most commonly associated with these injuries (33.2%) and the entanglement with moving parts, was the most cited mechanism (36.3%). This information is corroborated by Madeira (2011), where two-thirds of the accidents, occurred on rural properties in Minas Gerais, are related to agricultural tractors, and the contact with moving parts of the tractor, are the more frequent nature of accidents. In addition, a study of Cividino et al. (2018) in North-East of Italy showed that the power take-off (PTO) guards were missing in 24,7% of sampled tractors.

The power take-off (PTO), is a splined shaft located usually at the rear of the tractor above the drawbar. It presents the function of transmitting the power of the engine, through the cardan shaft, for the drive of agricultural machinery and equipment coupled to the tractor (Machado et al., 2017). Due to this fact, PTO becomes a hazard for accidents. In addition, contact with the shaft can cause serious accidents or fatalities, as their use is not always associated with adequate protection and safety measures. Thus, studies on ergonomics and safety, seek to inform and alert about the hazards involved in the operation of agricultural machinery and equipment. Complementarily, Brazilian laws and standards, like BRASIL (2013) and ABNT NBR ISO 500-1 (2016) standard, aim to minimize the risk of accidents in the interaction between man and machine.

The regulatory norm of occupational health and safety in agriculture, livestock, forestry and aquaculture, denominated BRASIL (2013), deals with agricultural machines and implements, determining the presence of a PTO master shield protection on agricultural tractors. The standard ABNT NBR ISO 500-1 (2016) Agricultural tractors – Rear mounted power take-off types 1, 2, 3 e 4, part 1 is about general specifications, safety requirements, dimensions for master shield and clearance zone.

In view of the mandatory PTO protection and the dimensional specifications presented by legislation and standards, the present study aims to verify the presence of PTO master shield in new agricultural tractors and master shield dimensional specification, according to the ABNT NBR ISO 500-1 (2016).

2 Materials and methods

2.1 Location and characterization

The study was carried out in the municipality of Santa Maria, central region of the state of Rio Grande do Sul, Brazil. For the data collection, technical visits were made in January, 2018 to seven agricultural tractors dealers installed in the municipality: Agrotec Comércio de Máquinas Agrícolas; RGS Agrícola; Green Mechanized Systems Vales; Dosul Machinery; Itaimbé Agricultural Machinery; Super Tratores Máquinas Agrícolas Ltda; Tritec Valtra Santa Maria, which represent the following brands^①: Agrale, Case, John Deere, LS Tractor, Massey Ferguson, New Holland and Valtra, respectively.

We evaluated new wheeled agricultural tractors, assembled or manufactured in Brazil in 2017. The tractors were available to the Brazilian market, through the dealerships of the respective manufacturers. The location, dealers, brands, and the number of tractors evaluated were based on the resources availability (material, human and infrastructure). It was attributed to each tractor brand evaluated, a general name: Brand A, Brand B, Brand C, Brand D, Brand E, Brand G and Brand H.

The study delimitation aimed to evaluate the tractor models' original factory characteristics, without worrying about the occurrence of changes that can be caused by the user or through field use.

2.2 Procedures for data collection

Data collection for this study covered a sample of 43 different agricultural tractors models, with power above 36.8 kW. These were available at the visited dealers, being: a) two models of Brand A; b) five models of Brand B; c) eleven models of Brand C; d) three models of Brand D; e) eight models of Brand E; f) eight models of Brand F; and g) six models of Brand G.

For further analysis, the tractors were grouped by engine power ranges, according to the characteristics of the PTO types, described at ABNT NBR ISO 500-1 (2016), as follows: Type 1 – less than 110 kW; Type 2 - between 110 kW and 130 kW; Type 3 - between 130 kW and 300 kW; and, Type 4 – between 300 kW and 450 kW.

^① The brands and/or dealers mention does not suggest approval or recommendation by the authors.

The data acquisition resulted from the visual verification of PTO master shield presence or absence, according to BRASIL (2013). Therefore, the dimensional variables of the PTO master shield were measured by the use of Tramontina Master 43156/303 measuring tape, according to ABNT NBR ISO 500-1 (2016) standard (Figure 1 and Table 1).

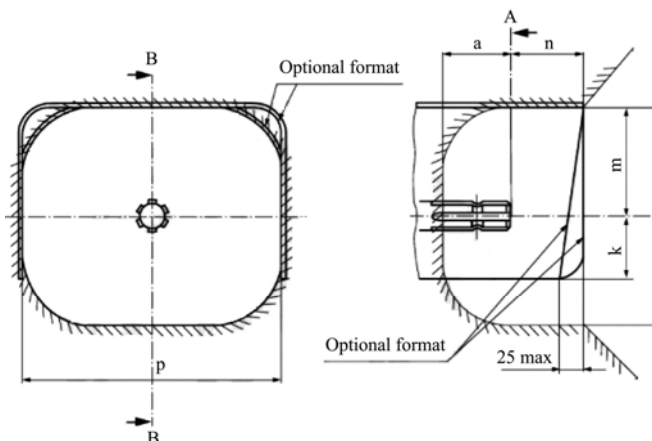

Note: Dimensions in millimeters; Source: BRASIL (2013); ABNT NBR ISO 500-1 (2016).

Figure 1 PTO master shield dimensions and clearance zone

Table 1 PTO master shield dimensions and clearance zone by PTO Type

Dimension	PTO type			
	1	2	3 ^a	4 ^b
a_{min}	80	80	95	105
$m \pm 5 \text{ mm}$	125	125	150	150
$n \pm 5 \text{ mm}$	85	85	100	100
$p \pm 10 \text{ mm}$	290	290	360	360
k_{min}	70	70	80	80

Note: Dimensions in millimeters.

^a for tractors equipped with TDP Type 3, which can be adapted to also provide a TDP Type 1 or 2, the master shield only needs to meet specifications for TDP type 3.

^b for tractors equipped with TDP Type 4, which can be adapted to also provide a TDP Type 1, 2 or 3, the master shield only needs to meet the specifications for TDP Type 4. Source: BRASIL (2013); ABNT NBR ISO 500-1 (2016).

This procedure was adopted in an analogous way for each tractor model available at the dealerships visited. Subsequently, the data collected were digitalized in an electronic file in Microsoft Excel® format, containing information about the models, power, brand, PTO master shield presence and respective dimensions.

3 Results and discussions

Regarding to the presence, 100% of the analyzed models contained the PTO master shield, satisfying the

BRASIL (2013) requirement. This fact, compared to the study by Corrêa et al. (2005) demonstrated evolution in the presence of safety items in Brazilian agricultural tractors. In the mentioned study, when verifying safety requirements on 487 tractors in use and 31 new ones, at São Paulo state, the authors observed 17.3% PTO master shield presence at used tractors and 71% at new tractors. In complement, in a study carried out by Corrêa et al. (2016), of the 112 tractors evaluated, 62.5% showed the presence of PTO master shield, indicating greater adherence to the norms by new tractors.

According to Reis and Machado (2009), old tractors were an aggravating factor for the occurrence of accidents, given the natural depreciation of the machine. Corroborating this profile, Cividino et al. (2018) said that missing protection devices are mostly related to tractor's old age and, in complement, Madeira (2011) showed that 89.5% of the tractors analyzed with more than 40 years of use did not show any type of protection at PTO area.

The importance of the presence of PTO master shield is related to the high response time of the human compared to the rotation involved. This is because the time between the perception of the movement situation and the reaction of the human being, takes an average of ¼ of a second. In that time interval, the PTO with 540 rpm rotation, for example, is capable of giving about 6 turns, rolling clothes, or even some body member. To reduce the possibility of accidents, always keep the PTO protection in place (Reis and Machado, 2009).

From the total of 43 models analyzed, 29 are in the range of Type 1 PTO, which corresponds to 67% of the sample. In relation to PTO Type 2 and Type 3, they corresponded to 1 and 13 models, characterizing 3% and 30% of the sample, in that order. Figure 2 shows the level of compliance of the protection dimensions, for each PTO Type.

The master shield dimension denominated 'a' showed complete compliance in the models evaluated with PTO Type 1 and 2, in addition to 53.85% of consonance in the models with PTO Type 3, standing out as the most consistent variable with the standard. While the dimensions 'm' and 'n' were, in general, the ones that presented lower levels of compliance, highlighting

negatively. Dimensions ‘a’ and ‘m’ refer to master shield frontal and lateral side, respectively, so the non-compliance may allow inadvertently access to the moving parts, contributing to accidents (Reis and

Machado, 2009), as in the cases reported in the virtual media (Guillen, 2011; Patriarca, 2014; Anon, 2015; Radar, 2016) and in the technical literature (Debiasi and Schlosser, 2002; Corrêa et al., 2003; Beer et al., 2007).

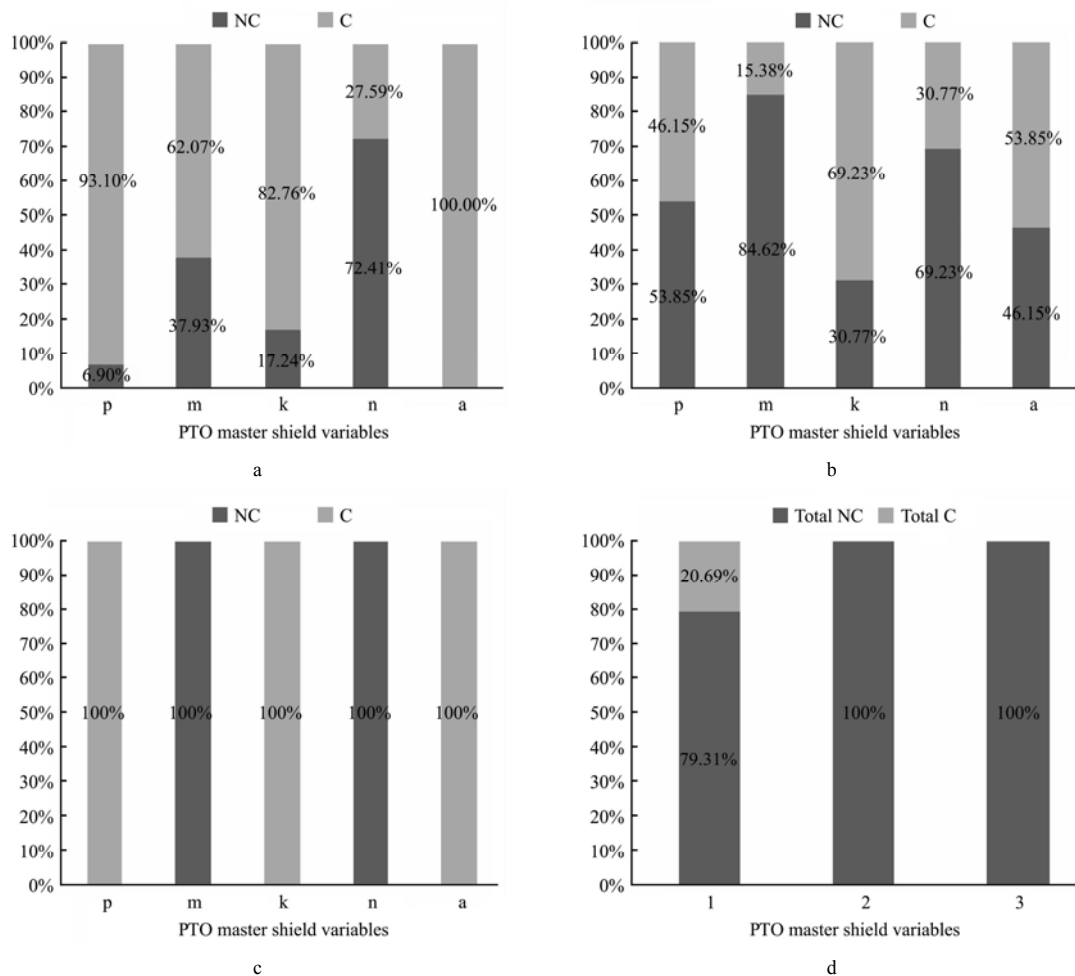

Note: NC: Non-compliant; C: Compliant.

Figure 2 PTO master shield dimensions’ compliance level of PTO Type 1 (a), Type 2 (b), Type 3 (c), and total compliance level (d)

When analyzing the total compliance level (Figure 2d), comparing PTO Types, it can be observed that analyzed agricultural tractors models with PTO Type 2 or 3 did not fully meet the current standard. This result may have been influenced by the sample size, mainly in the PTO Type 2, which corresponds to 3% of the total models. However, tractors with up to 110 kW of power, classified as PTO Type 1, 79.31% showed total compliance with the ABNT NBR ISO 500-1 (2016) requirements.

According to the Brazilian Yearbook of Tractors (2017), 57.5% of the total number of agricultural tractors models available in the country are offered in the power range of 37 kW to 147 kW. In accordance with data from Anfavea (2016), in the last two years, 47% of total tractor sales in Brazil were models with up to 59.7 kW of power

and approximately 30% in the power range of 59.7 and 97 kW. It should be noted that the greater availability of models and sales occur in the similar power range. It is observed a trend to increase tractor safety level when the tractor power was increased (Oldoni et al., 2017).

As believed by Debiasi and Schlosser (2002), the non-compliance of a standard could bring countless negative consequences. In a study carried out by the authors, the lack of tractors moving parts protection was one of the main causes of 75% of the accidents involving tractors in the central region of Rio Grande do Sul state in Brazil.

The PTO protection is part of top ten tractor safety items (Oldoni et al., 2017). The same authors indicated that the presence of safety items in tractors were directly

related to the final product purchase cost and, complementary, a lack of specific legislation could lead a low safety level tractor. In other hand, tractors with more safety items could lead a reduction in the number of accidents.

In order to characterize the accidents with agricultural tractors in the state of Minas Gerais, Brazil, Fernandes et al. (2014), observed among the various types of accidents found, the one with the highest level of risk was the

contact with moving parts of the tractor or implement. According to the same authors, this was due to the fact that the contact with the cardan shaft was the occurrence with the highest frequency among the reported accidents, as well, present a high level of severity.

Figure 3 shows the level of compliance of PTO master shield dimensions by tractor brand assessed (A – G) and the total compliance level (H).

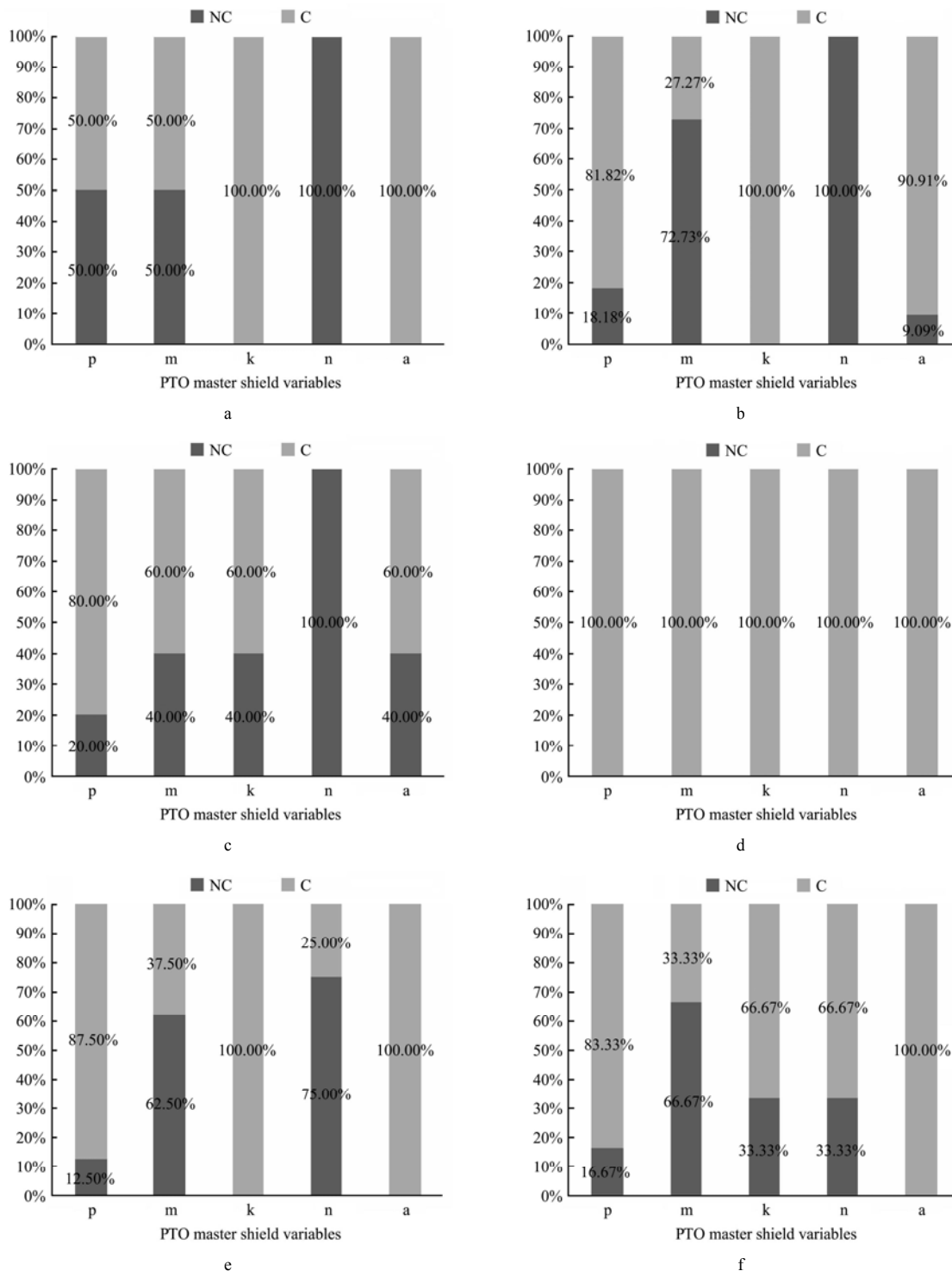

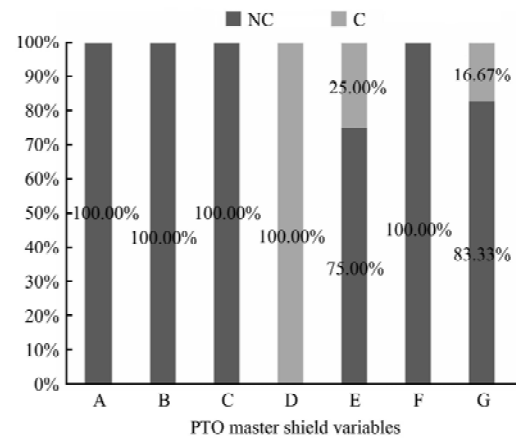
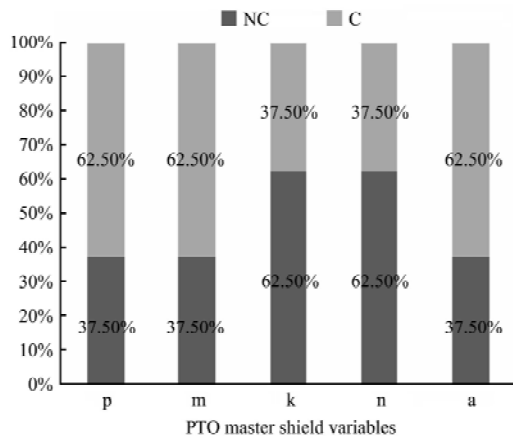

NC: Non-compliant; C: Compliant.

Figure 3 PTO master shield dimensions' compliance level by tractor brand - Brand A (a), B (b), C (c), D (d), E (e), F (f), G (g) and total compliance level (h)

The dimensions 'a', 'p' and 'k' presented a higher percentage of non-compliance in Brands B, C, D, E and G. On the other hand, the dimensions 'm' and 'n' presented less compliance in Brands A, B, C, D, E and F. The PTO master shield presence is of paramount importance, but its correct dimensions is of equal significance for preventing accidental contact with moving parts.

When analyzing Figure 3h, it was observed that four of seven brands covered showed total non-compliance (Brands A, B, C and F), two brands (E and G) presented non-compliance in most of the PTO master shield dimensions and only Brand D showed 100% compliance in all analyzed variables. This result indicates that there is no standardization by the Brazilian agricultural tractors manufacturers on the dimensional aspect of the PTO master shield.

This result is consistent with Lima et al. (2005) who indicated that machines were placed on the market without apparent concern of their manufacturers regarding to the certain parameters that were essential to the work performance, such as comfort and safety, which could favor the occurrence of agricultural machinery accidents. Mattar et al. (2010) highlighted the need of more compliance from national agricultural tractors manufacturers on norms and standards related to occupational safety. In addition, Balestra (2008) stated that tractor manufacturers, although they knew certain technical standards, did not apply them, did not contribute to the products homogeneity.

In the product design, the safety requirements

fulfillment must be foreseen, both in the informational and in the conceptual phase of the project. Another important aspect is related to the company's product safety strategic planning, as Alonço (2004) explains. In this way, it can be understood that the companies analyzed use different safety policies, according to the restriction of the market in which they operate, or they do not follow a consistent process of product development that identifies all the safety needs applicable.

Regardless of the consumer market, it is imperative that agricultural tractors fully comply with applicable legislation and standards in order to reduce possible causes of accidents. According to Mattar et al. (2010) compliance with tractors safety standards, allows better ergonomic conditions to operators, acting as a preventive action to possible occupational accidents.

4 Conclusions

Every tractor model evaluated has PTO master shield. However, the results were unsatisfactory in relation to the PTO master shield dimensional compliance. In this sense, 20.69% of tractors with PTO Type 1 and 100% with PTO Type 2 and 3 did not fully meet the requirements of ABNT NBR ISO 500-1 (2016).

Related to the analyzed brands, 57% showed total non-compliance on PTO master shield dimensions. In addition, 29% of brands showed non-compliance in most of the studied variables, and only one brand showed 100% compliance in all PTO master shield dimensions.

Agricultural tractors are being made available to the

Brazilian market, with non-compliance from manufacturers in relation to certain parameters in PTO master shield dimensions, which may favor the accidents occurrence.

Acknowledgment

The authors thank the National Council for Scientific and Technological Development (CNPQ).

References

- ABNT – ASSOCIAÇÃO BRASILEIRA DE NORMAS TÉCNICAS. 2016. NBR/ISO 500-1. Agricultural Tractors - Initial Potentiality Take 1, 2, 3, 4. Part 1: General specializations, safety requirements, dimensions for protection and sessions. Rio de Janeiro: ABNT.
- Alçayır, A., and H. Haciseferoğulları. 2017. Assessment of tractor and agricultural machine accidents happened in agricultural enterprises of Çumra town of Konya province. *Selcuk Journal of Agriculture and Food Sciences*, 31(3): 169–176.
- Alonço, A. S. 2004. Design methodology for safe agricultural machinery. Ph.D. diss., Santa Catarina Federal University, Florianópolis.
- ANFAVEA - NATIONAL ASSOCIATION OF MOTOR VEHICLE MANUFACTURERS. (2016). Brazilian automotive industry directory 2017. <http://www.anfavea.com.br/estat%3%adsticas.html>. Accessed 18 March 2017.
- Anon. 2015. 11-year-old child dies in tractor accident. PORTAL TRI. Dionísio Cerqueira, SC. Available at: <http://www.portaltri.com.br/1/noticias/4/geral/44868/crianca-d-e-11-anos-morre-em-acidente-comtrator>. Accessed 2 August 2018.
- Balestra, M. R. G. 2008. Survey and identification of graphic symbols used to characterize commands and controls, for agricultural tractors. Ph.D. diss., Agricultural Engineering post-graduation program, Santa Maria Federal University., Santa Maria.
- Beer, S. R., G. R. Deboy, and W. E. Field. 2007. Analysis of 151 agricultural driveline-related incidents resulting in fatal and non-fatal injuries to U.S. children and adolescents under age 18 from 1970 through 2004. Available at: <http://www.ncbi.nlm.nih.gov/pubmed/17555204>. Accessed 2 August 2018.
- BRASIL. 2013. *NR 31 - Occupational safety and health in agriculture, livestock, forestry, forestry and aquaculture*. Brasília: Ministry of Labor and Employment.
- Brazilian Yearbook of Tractors. 2017. *Revista Cultivar Máquinas*, 1(1).
- Cividino, S. R. S., G. Pergher, N. Zucchiatti, and R. Gubiani. 2018. Agricultural health and safety survey in Friuli Venezia Giulia. *Agriculture*, 8(1): 9.
- Corrêa, I. M., C. A. Moreira, S. R. Filipini, R. D. C. Mello and P. S. Pontes. 2016. Evaluation of agricultural cardan shafts in the field. *Applied Research & Agrotechnology*, 9(2): 71–77.
- Corrêa, I. M., R. Y. Yamashita, H. H. Ramos, and A. V. F. Franco. 2003. Profile of rural accidents in agencies of the INSS of São Paulo at year 2000. *Revista Brasileira de Saúde Ocupacional*, 28(107/108): 39–57.
- Corrêa, I. M., R. Y. Yamashita, A. V. F. Franco, and H. H. Ramos. 2005. Verification of safety requirements of agricultural tractors in some municipalities of the state of São Paulo. *Revista Brasileira de Saúde Ocupacional*, 30(111): 25–33.
- Debiasi, H., and J. F. Schlosser. 2002. Tractor accidents. *Cultivar Máquinas*, 12(2): 28–33.
- Fernandes, H. C., N. G. Madeira, M. M. Teixeira, P. R. Cecon, and D. M. Leite. 2014. Accidents with agricultural tractors: nature, causes and consequences. *Engenharia na Agricultura*, 22(4): 361–371.
- Gerhard, M. 2016. An environmental history of the modernization of agriculture: the north of Rio Grande do Sul. *História: Debates e Tendências*, 16(1): 166–180.
- Gonçalves, M. C. V. 2017. Agribusiness and the mechanization of work in the field: between profit, precariousness and exclusion. In *VIII Jornada de políticas públicas*, Maranhão, Brazil, august 2017.
- Guillen, F. 2011. Accident with tractor leaves farmer in serious condition in Mamborê. Available at: <http://www.gazetadopovo.com.br/vida-e-cidadania/maringa/acidentecom-trator-deixa-agricultor-em-estado-grave-em-mambore-c0usq02un6lqqeum7vuswk18u>. Accessed 2 August 2018.
- Lima, J. S. S., A. P. Souza, C. C. Machado, and R. B. Oliveira. 2005. Evaluation of some ergonomic factors in the "Feller-buncher" and "Skidder" tractors used in harvesting wood. *Revista Árvore*, 29(2): 291–298.
- Lubicky, J. P., and J. R. Feinberg. 2009. Fractures and amputations in children and adolescents requiring hospitalization after farm equipment injuries. *Journal of Pediatric Orthopedics*, 29(5): 435–438.
- Machado, T. A., A. G. Costa, J. B. Cunha. 2017. How to use. *Revista Cultivar Máquinas*, 174(15): 9–11.
- Madeira, N. G. 2011. Work safety in operations with agricultural tractors in regions of Minas Gerais. Ph.D. diss., Agricultural Engineering post-graduation program, Viçosa Federal University., Viçosa.
- Mattar, D. M. P., A. U. Dallmeyer, J. F. Schlosser, and M. E. Dornelles. 2010. Conformity of accesses and exits of agricultural tractor stations according to NBR/ISO 4252 standard. *Revista Engenharia Agrícola, Jaboticabal*, 30(1):

- 74–81.
- Monteiro, L. A. 2010. *Accident Prevention with Agricultural and Forest Tractors*. Botucatu: Diagrama.
- Oldoni, A., R. T. Spagnolo, C. S. De Moraes, M. A. N. Da Rocha, A. L. T. Machado, and Â. V. dos Reis. 2017. Safety index for agricultural tractors. *Acta Scientiarum Technology*, 39(1): 9–15.
- Patriarca, P. 2014. Rural worker dies in tractor accident. Available at: <http://www.jcnet.com.br/Regional/2014/09/trabalhador-rural-morre-em-acidente-com-trator.html>. Accessed 2 August 2018.
- Radar, C. L. 2016 Young man has foot amputated in tractor accident. Available at: <http://www.radaraltovale.com/noticia/antenido/jovem-tem-o-pe-amputado-em-acidentecom-trator-26094#.V4POTPkLIU>. Accessed 5 July 2016.
- Reis, A. V., and A. L. T. Machado. 2009. *Accidents with Agricultural Machinery: Reference Text for Technicians and Extension Workers*. Pelotas, Rio Grande do Sul, Brazil: Publisher and Graphic University Pelotas.
- Rinaldi, P. C. N., H. C. Fernandes, M. M. Teixeira, P. R. Cecon, and C. B. Alvarenga. 2016. Diagnosis of power and torque of agricultural tractors manufactured and marketed in Brazil. *Engenharia na Agricultura, Viçosa*, 23(3): 246–256.
- Schlosser, J. F. 2001. *Tractors agricultural. Technical series I*. UFSM, Department of Rural Engineering, Santa Maria: university press.
- Vian, C. E. F., A. M. A. Júnior, L. G. Baricelo, and R. P. Silva. 2013. Origins, evolution and trends of the agricultural machinery industry. *Brazilian Journal of Rural Economics and Sociology*, 51(4): 719–744.