

Justification of a finger device for feeding sesame plants into harvester

Stoyan Ishpekov^{*}, Nayden Naydenov, Petar Petrov, Rangel Zaykov

(*Department of Mechanization, Agricultural University, 4000 Plovdiv, Bulgaria*)

Abstract: The objective of the study is to give a proof of a technological scheme and basic parameters of a new device for feeding sesame plants into the harvesting machine at reduced seed scattering. The kinematics of the point of contact between the plant and a finger of the feeder conveyor was investigated. The laws for the displacement and the velocity of that point were synthesized. They were used to determine the displacement of the contact point on the stem, the kinematic factor of the conveyors and to calculate the position of the knife to the point of initial contact of fingers with the plant. The operation of the new device requires adjusting the longitudinal slope of the conveyors from 0° to 10° and their kinematic factor of 1.1 to 1.5. To ensure a sufficient slope of the stem over the header in the moment of cutting, it is necessary to adjust the distance of the blade to point of initial contact with fingers from 0.05 to 0.30 m. The expressions obtained can be used to determine the basic parameters of a finger device for feeding sesame stems in a harvesting machine as well as for manufacturing a sesame header for grain harvesters.

Keywords: sesame harvesting, mechanization

Citation: Ishpekov S., N. Naydenov, P. Petrov and R. Zaykov. 2019. Justification of a finger device for feeding sesame plants into harvester. *Agricultural Engineering International: CIGR Journal*, 21(1): 100–108.

1 Introduction

In recent years, many scientific studies are carried out to mechanize the harvesting of sesame seeds without significant losses from scattering (Langham, 2014). Research has begun with a study of the capability of the grain harvester to harvest sesame in many places of the world (Langham et al., 2008). The first results testify to total seed losses of about 50%. Harvesting sesame of non-shattering variety Nevena with a New Holland CX8060 grain harvester are reported from 20% to 22% scattered seed by the header (Trifonov et al., 2014). Two-phase mechanized harvesting of sesame does not show good results either (Naydenov et al., 2016). Studies with different devices and machines showed the seed were scattered from 20% to 65% (Leffel and Rick, 1988).

The conventional reel is considered one of the perfect

devices for feeding stems in harvesting machine. Unfortunately, its paddles enter between the plants from above before tilting them to the header. When harvesting sesame the paddle wedges between the central stem and capsules or branches because they conclude a sharp angle to each other. As a result, the reel bends the stems to the soil surface and shakes them before their feeding into the header, which leads to significant scattering of seeds (Langham, 2014). For this reason, it is not the suitable device for feeding sesame stems into the header. Unsatisfactory results are obtained when harvesting sesame with headers for rapeseed, sunflower and soybean (Zareei and Abdollahpour, 2016). Apparently, the existing devices do not meet requirements for feeding sesame plants to harvesting machine and therefore it is necessary to justify a new one that does not scatter seed on the field.

The release of seeds caused by a lateral mechanical impact for feeding sesame stems into harvester is investigated in order to define the conditions for reducing losses. It is found that the mentioned feeding reduces

Received date: 2018-01-03 **Accepted date:** 2018-07-16

*** Corresponding author: Stoyan Ishpekov**, Agricultural engineering department, Agricultural University Plovdiv 4000, Bulgaria. Email: sishpekov@abv.bg.

losses of seed's scattering up to four times compared with feeding of stems by the conventional reel (Ishpekov et al., 2017).

The purpose of the study is to substantiate the basic parameters of a new mechanical device for feeding sesame stems into the harvester at reduced seed scattering.

The tasks of the study are:

- Development of the technological scheme of the new device;
- Analyzing the impact of device on a sesame plant;
- Determination the accuracy of the results obtained.

2 Method and materials

2.1 Development of the technological scheme

The technological scheme of a new device was developed based on the obtained results for lateral mechanical impact for feeding sesame stems into harvester (Ishpekov et al., 2017). Besides, it should meet the following requirements:

- Ensuring a continuous technological process and rectilinear movement of stems;
- Delivering plants in the header without significant shaking;
- Stroke - less cutting off stems, which is taking place after their tilting over the header.

2.2 Theoretical analysis for the impact of the device on a sesame plant

It was made by kinematic analysis. The law of displacement the contact point between the device and the sesame stem was synthesized by applying the geometric approach. The law was applied to define the conditions for tilting the stem over the header depending on the kinematic factor of device. A numerical experiment was conducted to determine the factor values that are applicable in practice. The theoretical condition for minimal displacement of the contact point over the stem at it feeding to the header was defined. This condition ensures feeding of the sesame stems without wedging and shaking. Based on the theoretical results obtained, a second numerical experiment was conducted to determine the effect of factors affecting to the displacement of the contact point. Theoretically, the distance of the knife to the point of initial contact between the plant and the device was justified. Via third numerical experiment, the

optimal position of the knife depending on its height from the soil and the slope of the stem at the time of its cutting from the root was determined.

The theoretical results were compared with the field impact that single sesame plant endures without scattering its seeds significantly (Ishpekov et al., 2017). Based on the results of the numerical experiments, lines on equal level were drawn using the '3D Custom Function Plot' procedure of the Statistica software (www.statsoft.com). The area with practically significant values was marked with different color.

2.3 Determining the accuracy of obtained results

The accuracy of the study was determined by the difference between theoretical and field results for the following indicators:

- The value and direction of the displacement of the contact point between a finger of the device and the plant during its tilting to the header;
- The slope of the stem at the moment of its cutting off.

Field results were obtained through a manufactured experimental of one-row finger device that achieves the parameters substantiated in the theoretical studies. The device acts on a single sesame stem that is fixed vertically between two metal profiles. A laboratory - field experiment with three replications was performed on a horizontal plot. In this experiment, the responses were the mentioned indicators and the controllable factor was the longitudinal slope of the device.

3 Results and discussion

3.1 Technological scheme

The new device consists of platform - 7, rotary knife - 1, chain wheels - 2 and 6, fingers - 3 and two chain - fingers conveyors - 4 (Figure 1). In operation, the new device moves forward with a velocity v_M . The two conveyor chains - 4 form a common groove in which they move in the opposite direction with a velocity v_b . They approach the plant bilaterally and tilt the stem towards the header by means of the fingers - 3.

The tilting of stem begins at point M_0 and continues to point M_1 where the knife - 1 cuts it from the root. Afterwards, the conveyors - 4 feed the stem into the header. While the finger moves from M_0 to M_1 , the

machine travels the path A_0A_1 . It is obvious that the work of the new device is determined by the impact of the fingers on the plant, which was called ‘finger type’.

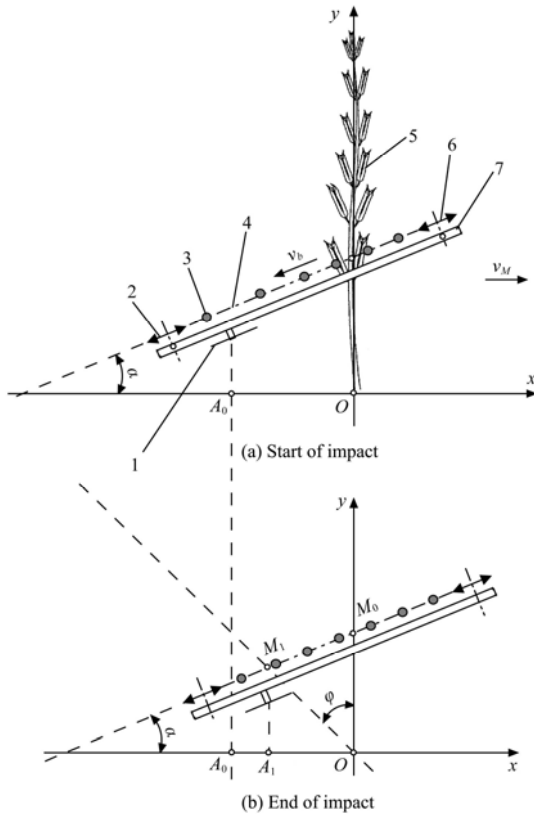

1. Rotary knife 2, 6. Chain wheels 3. Fingers 4. Chain - fingers conveyors
5. Sesame stem 7. Platform

Figure 1 Technological scheme of a finger device for feeding sesame stems into harvesting machine

3.2 Impact of the finger device on a sesame plant

The theoretical analysis is carried out under the following prerequisites:

- Neighboring plants do not interact each other when tilting;
- The sesame stem is approximated with the straight segment OM_1 , which rotates about the boundary point with the soil when applying the tilting effort.

M is the contact point between the plant and the finger of the conveyor (Figure 2).

The kinematic of the point M is analyzed because it influences the efficiency of the new device.

3.2.1 Law of movement of the contact point

An absolute Cartesian coordinate system xOy is introduced with a starting point O , which is situated in the border between roots of the stem. The horizontal axis x is toward the direction of moving the machine, and the vertical axis y - along the vertical stem. The contact point M participates simultaneously in two translational motions:

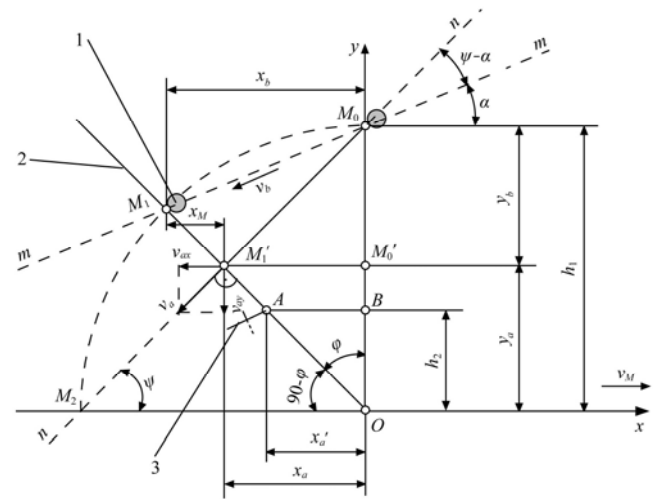

1. Finger 2. Sesame plant 3. Rotary knife
Figure 2 Kinematic scheme

- Transport motion, which is from the displacement of machine about xOy ;

- Relative motion, which is from the displacement of chains toward the machine.

The following symbols are entered:

x_M, y_M - the coordinates of the point M in the forward motion, (m);

x_b, y_b - the coordinates of the point M in the relative motion, (m);

x_a' - the horizontal coordinate of the knife blade, (m);

h_1 - the distance from the soil surface to the point M at the moment of grabbing the plant by the front finger, (m);

h_2 - the height of the knife to soil surface, (m);

α - the inclination of the conveyor relative to the direction of movement of the machine, ($^\circ$);

φ - the angle of inclination of the stem to vertical, ($^\circ$);

ψ - the angle between the trajectory of point M (line $n-n$) and axis x , ($^\circ$);

t - the time for moving of point M , (s);

v_M - the forward speed of the machine, ($m\ s^{-1}$);

v_b - the chain speed, ($m\ s^{-1}$);

v_{ax} - the projection of absolute speed by axis x , ($m\ s^{-1}$);

v_{ay} - the projection of absolute speed by axis y , ($m\ s^{-1}$);

The absolute displacement of the point M was presented by the coordinates x_a and y_a (Figure 2).

$$\begin{cases} x_a = x_M - x_b \\ y_a = y_M - y_b \end{cases} \quad (1)$$

The change of the coordinate x_M is:

$$x_M = v_M t \quad (2)$$

Moving of point M relative the machine along the axis x is:

$$x_b = v_b t \cos \alpha \quad (3)$$

The forward motion $y_M = const$, therefore

$$y_M = h_1 \quad (4)$$

The coordinate of the point M on axis y of the relative motion is:

$$y_b = v_b t \sin \alpha \quad (5)$$

After substituting Equations (2), (3), (4) and (5) in Equations (1), we get the law of moving the contact point:

$$\begin{cases} x_a = v_M t - v_b t \cos \alpha \\ y_a = h_1 - v_b t \sin \alpha \end{cases} \quad (6)$$

We substitute

$$\frac{v_b}{v_M} = \lambda \quad (7)$$

where, λ is the kinematic factor of the finger device.

After rendering of Equation (7), the law (in Equation (6)) acquires the species

$$\begin{cases} x_a = v_M t (1 - \lambda \cos \alpha) \\ y_a = h_1 - \lambda v_M t \sin \alpha \end{cases} \quad (8)$$

To obtain the equation for the displacement of point M , the time t from the first system Equation (8) is off -

$$t = \frac{x_a}{v_M (1 - \lambda \cos \alpha)} \quad (9)$$

For the second equation of system (Equation (8)) we get:

$$y_a = h_1 - \frac{\lambda \sin \alpha}{1 - \lambda \cos \alpha} x_a \quad (10)$$

Here

$$\frac{\lambda \sin \alpha}{1 - \lambda \cos \alpha} = k \quad (11)$$

where, k is the angular coefficient of the straight line $n-n$.

Thus, Equation (10) acquires the species:

$$y_a = h_1 - k x_a \quad (12)$$

$$k = tg \psi \quad (13)$$

The Equation (12) shows that the trajectory of point M is a straight line. In order to determine the angle to x axis, we substitute Equation (11) in Equation (13):

$$\psi = \arctg \frac{\lambda \sin \alpha}{\lambda \cos \alpha - 1} \quad (14)$$

To obtain the components of the absolute velocity v_a on both axes we differentiate Equation (8).

$$\begin{cases} v_{ax} = v_M (1 - \lambda \cos \alpha) \\ v_{ay} = -\lambda v_M \sin \alpha \end{cases} \quad (15)$$

The absolute velocity of point M is:

$$v_a = \sqrt{v_{ax}^2 + v_{ay}^2} \quad (16)$$

After replacing Equation (15) in Equation (16), we obtain the absolute velocity of the point M in dependence on the kinematic factor λ , the forward speed of the machine v_M and the slope of the conveyors relative to the horizontal - α :

$$v_a = v_M \sqrt{\lambda^2 - 2\lambda \cos \alpha + 1} \quad (17)$$

3.2.2 Condition for tilting the stem to the header

For tilting the stem in direction opposite of the machine forward speed, it is necessary:

$$v_{ax} \leq 0 \quad (18)$$

This condition is achieved by changing the kinematic factor λ . After substituting Equation (15) in Equation (18) the condition for its minimum value is obtained -

$$\lambda \geq \frac{1}{\cos \alpha} \quad (19)$$

Figure 3 presents the result for the influence of the conveyors slope α on the minimum value of the kinematic factor - λ . It is clear that the kinematic factor λ must be greater than one in order to ensure tilting the stem to header. Moreover, increasing the slope α requires an increase of the minimal value of kinematic factor.

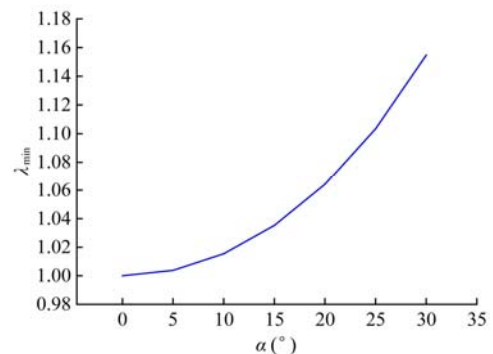

Figure 3 Minimal value of kinematic factor λ depending on conveyors slope α

3.2.3 Condition for minimal displacement of the contact point relative to the stem

The movement of the contact point M on the stem is minimal when the distance $M_1 M_1'$ approaches to zero (Figure 2). This is observed when the direction of the

absolute velocity of the finger is perpendicular to the stem, i.e. at:

$$\psi = \varphi \tag{20}$$

Therefore

$$\operatorname{tg}\psi = \operatorname{tg}\varphi \tag{21}$$

From Equation (15) we have

$$\operatorname{tg}\psi = \frac{v_{ay}}{v_{ax}} = \frac{-\lambda \sin \alpha}{1 - \lambda \cos \alpha} \tag{22}$$

After converting of Equations (21) and (22) we get:

$$\lambda \leq \frac{\operatorname{tg}\varphi}{\cos \alpha \operatorname{tg}\varphi - \sin \alpha} \tag{23}$$

The resulting inequality is a condition for the maximal value of kinematic factor λ , at which achieves the minimum displacement of the contact point M on stem. From Equations (19) and (23) we get the final conditions

$$\frac{1}{\cos \alpha} \leq \lambda \leq \frac{\operatorname{tg}\varphi}{\cos \alpha \operatorname{tg}\varphi - \sin \alpha} \tag{24}$$

The result from a numerical experiment based on the Equation (23) is presented in Figure 4. It is seen that the maximum value of kinematic factor can reach 3.

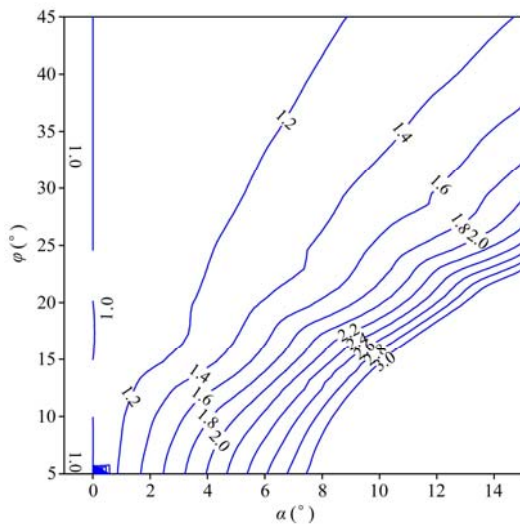

Figure 4 Kinematic factor λ_{\max} depending on conveyors slope α and the slope of the stem φ at $\varphi=\psi$

3.2.4 Displacement of the contact point along the stem

The contact point between finger and stem is located in the zone with capsules and branches. It slides along the stem when tilting it to the header. If the sliding is directed to the root, then the finger wedges in the branches or capsules and bends the central stem because the angle between them is sharp. Therefore, the displacement of the contact point must be minimal and directed to the top of

the plant.

The displacement of the contact point is in the direction of its absolute velocity v_a (Equation (17)). It depends on the kinematic factor and on the slope of the conveyors. At $\lambda=\text{constant}$ we consider the following cases:

- The conveyor slope is negative ($\alpha < 0$), which means that its front end is closer to the soil surface than the rear;
- The conveyor is horizontal ($\alpha = 0$);
- The conveyor slope is positive ($\alpha > 0$).

At $\alpha < 0$, the impact of the finger starts from point M_0 and continues to point M_1 where the knife cuts the stem (Figure 5a). The displacement Δ is equal to the segment M_1M_1' and is directed to the top of the plant.

At $\alpha = 0$, the directions of the absolute velocity of the contact point v_a and the speed of the conveyor v_e coincide (Figure 5b). The displacement Δ is directed to the top of the plant, but at the conditions of the study are less than in the first case.

At $\alpha > 0$, the displacement of the contact point is directed to the root of the plant (Figure 5c). This creates conditions for wedging of the fingers between the stem and the capsules or branches.

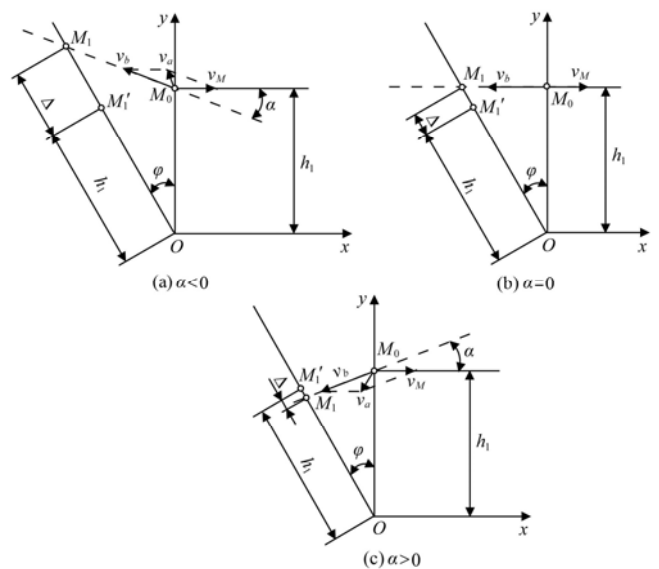

Figure 5 Direction of the absolute velocity of the contact point v_a on the stem at $\lambda=\text{constant}$

The examined cases are in effect when sesame stem is approximated with a straight line that bends only at the boundary with the soil at it is inclining above the header. In fact, the stems bend their entire length in a different way depending on the variety and condition of the plants during harvest. Therefore, the magnitude and direction of

sliding of the contact point along the stem should be determined experimentally.

To consider the case when the displacement is the largest and denote it with Δ_{max} . This is observed at $\varphi = \psi$, when the stem is perpendicular to the absolute trajectory $n-n$ of point M and the angle $\alpha > 0$ (Figure 2). From the triangle OM_0M_1' we have

$$M_0M_1' = h_1 \sin \varphi \tag{25}$$

From the triangle $M_0M_1M_1'$ we can write

$$\Delta_{max} = h_1 \sin \varphi \operatorname{tg}(\psi - \alpha) \tag{26}$$

When $\varphi = \psi$

$$\Delta_{max} = h_1 \sin \psi \operatorname{tg}(\psi - \alpha) \tag{27}$$

Two numerical experiments were conducted to study Δ_{max} . In the first one, we examined the influence of the angle ψ by using the dependence (22) given in the form:

$$\psi = \operatorname{arctg} \frac{\lambda \sin \alpha}{\lambda \cos \alpha - 1} \tag{28}$$

The kinematic factor λ changes from 1.1 to 1.5 and the slope of the α conveyor from 0 to 10 degrees. In the second numerical experiment, we examined Δ_{max} via Equation (27) depending to the calculated values of ψ and the mentioned values of α and λ .

The results confirmed that the slope of the stem φ was the greatest and the displacement of the contact point was the least ($\Delta = 0 \div 0.05$ m) and directed to top of the plant at $\alpha = 0^\circ \div 7^\circ$ and $\lambda = 1.1 \div 1.5$ (Figure 6).

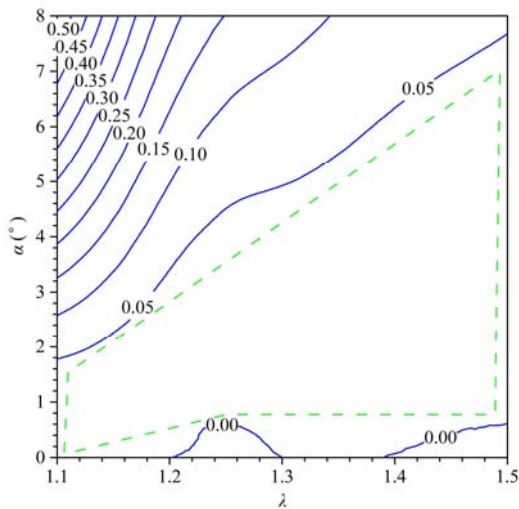

Figure 6 Displacement Δ (m) of the contact point depending on α and λ at $\psi = \varphi$ and $h_1 = 0.5$ m. The marked zone is recommended for working mode

The kinematic factor has insignificant effect on the displacement of the point M when α is in the range from 0

to 2° . However, in the range of 2° to 7° , the increase of λ leads to reduction of the displacement Δ and inclination of the stem φ (Figure 7).

The results obtained are valid at $\varphi = \psi$. When $\varphi > \psi$ the displacement of the point M changes its direction. Obviously, to minimize the displacement of the contact point on the stem, the longitudinal slope of the conveyors must be an adjustable parameter.

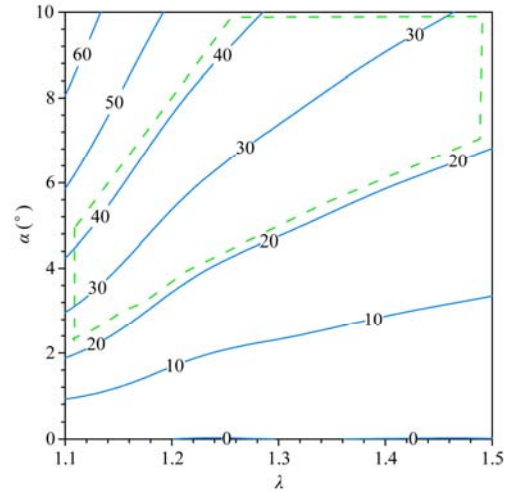

Figure 7 Inclination ψ ($^\circ$) of the trajectory of the contact point depending on the tilting angle of the conveyor α and the kinematic factor λ at $\psi = \varphi$ and $h_1 = 0.5$ m. The marked zone is recommended for working mode

3.2.5 Determining position of the knife

In order the stem to fall over the header, it is necessary to fix the knife correctly about the point of initial contact of plant with the finger. Let us denote the coordinate of the blade towards the abscissa with the x_a' (Figure 2). For triangles OAB and $OM_1'M_0'$ are valid:

$$\sphericalangle BOA = \sphericalangle M_0'OM_1' = \varphi$$

$$\sphericalangle OAB = \sphericalangle OM_1'M_0' - \text{corresponding angles, therefore}$$

$$\Delta OM_0'M_1' \sim \Delta OBA$$

From the similarity of both triangles it follows that:

$$\frac{x_a'}{x_a'} = \frac{y_a}{h_2} \tag{29}$$

From here we get

$$x_a' = h_2 \frac{x_a}{y_a} = h_2 \operatorname{tg} \varphi \tag{30}$$

The Equation (30) determines the factors that affect the horizontal coordinate of the knife blade. They are the height of the blade above the soil surface h_2 and the slope of the stem at the time of its shearing off - φ .

The third numerical experiment is based on Equation (30). The height of the knife h_2 relative to the soil surface changes from 0.1 to 0.7 m and the slope of the stem φ relative to the vertical axis from 0 to 70°. In Figure 8, it is evident that the increase in the slope of stem φ requires the growing of the distance x_a' . At a constant angle φ , this distance grows with increasing the height of the knife relative the soil surface h_2 .

The position of the knife must allow cutting stems under the lowest capsule. Contemporary non shattering sesame varieties lay their capsules at a height more than 0.3 m from soil surface (Stamatov and Deshev, 2018). If the height of the blade is $h_2=0.25$ m, the losses of seeds are avoided both from low-situated capsules and from the unevenness of the field, whose cause fluctuations of the shear height of plants.

For $h_2 = 0.25$ m and $\varphi = 20^\circ$ the horizontal coordinate of the knife blade should be $x_a' = 0.083$ m (Figure 8). These conditions change in practice and for this reason it must be ensured an adjustment of the distance from the blade to the initial point of contact between the stem and the fingers in the range from 0.06 to 0.20 m.

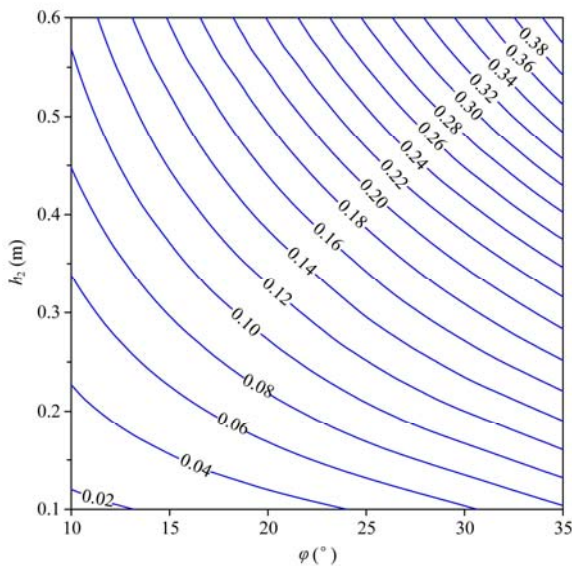
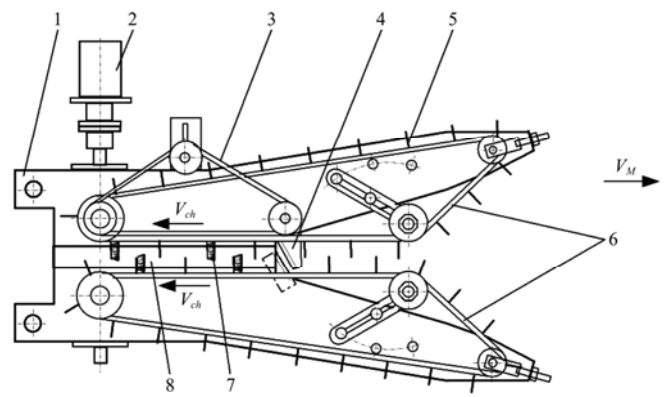

Figure 8 Coordinate of the knife blade x_a' (m) depending on its height to soil surface h_2 and the slope of stem φ at the time of its shearing off

3.2.6 Results accuracy

The theoretical data are calculated by the Equations (27) and (28). The field results are obtained through an experimental device, which was developed based on the theoretical studies at the Agricultural University - Plovdiv (Figures 9 and 10) (Ishpekov et al., 2018).



(a) General scheme

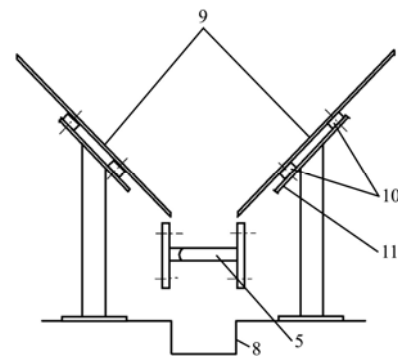

(b) Collecting surface

1. Platform 2. Hydro motor 3, 6. Chains 4. Rotary blade 5. Fingers
7. Brushes 8. Central groove 9. Collecting surface 10. Beams 11. Support plate with channels

Figure 9 Finger device for feeding sesame stems into harvesting machine



Figure 10 Photo of the one-row experimental device for feeding sesame stems

An experiment with three replications was conducted on a horizontal flat terrain. The responses were the indicators mentioned in 2.3 and the controllable factor was the longitudinal slope of the experimental device. The actual displacement of the contact point on the stem - Δ_r is determined by the Equation (31) (Figure 2)

$$BM_0 - AM_1 = \Delta_r \quad (31)$$

where, BM_0 is the distance from the blade to the initial contact point between finger and plant, (m); AM_1 is the distance from the blade to the contact point at the moment of cutting the stem, (m).

The slope of stem at the moment of its cutting (Figure 2) is calculated by the expression

$$\varphi_r = 90 - \varphi_{sec} \quad (32)$$

where, φ_r is the actual slope of stem at the time of cutting ($^\circ$); φ_{sec} is the angle between the surface of cut and the axis of stem, ($^\circ$).

In fact, these two angles replace the angle φ from the theoretical research.

Before the experiment, one sesame stem - 2 was attached vertically between two horizontal metal profiles - 1 (Figure 11). They were positioned so that the gap between them is coaxial to the groove between the two conveyors and the front finger - 4 was touched the stem. A white thread - 3 was tied to the touch point of stem, which serves as a scoring mark for measuring the segments BM_0 and AM_1 . Afterwards, the profiles are dragged parallel for a distance of 1.5 m in front of the device. It was starting and moving forward up to cutting the stem. The distance from the scar to the surface of cut was measured, which is the real length of the segment AM_1 .

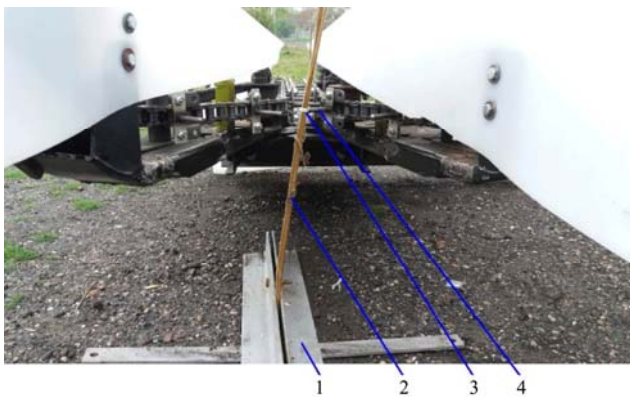

(a) Equipment

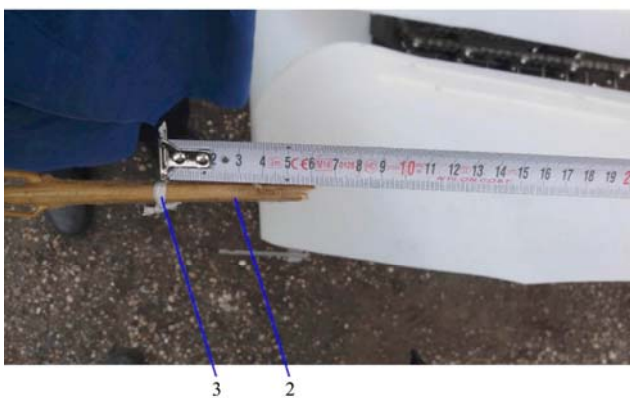

(b) Distance from the scar to the surface of cut

1. Metal profiles 2. Sesame stem 3. Scar 4. Front finger of the device

Figure 11 Determining the actual displacement of the contact point between the finger of device and a stem

The results of the last experiment are presented in Figure 12. They testify that when working with horizontal conveyors ($\alpha=0^\circ$) the segment AM_1 decreases from 75 mm in the vertical position of the stem to 26.7 mm at shearing. Therefore, the contact point between finger and stem moves to the top of the plant. When working with a negative slope of the conveyors ($\alpha=-4^\circ$) the segment AM_1 is prolonged to 96.7 mm as a result of moving the contact point to the root of the plant. This case is the most disadvantageous for the technological process because it creates the prerequisites for wedging the finger between the central stem and the capsules or side branches. When working with a positive slope of conveyors ($\alpha=4^\circ$) the segment AM_1 is changing its length at least. The average displacement of the contact point is $\Delta_r=9.8$ mm which exceeds the theoretically determined by 10.2%. The displacement Δ_r is less than the length of a sesame capsule, which greatly reduces the risk of wedging the finger in the central stem. In fact, the displacement of the contact point on the stem does not reach zero due to the vertical oscillations of the device at motion on the soil surface.

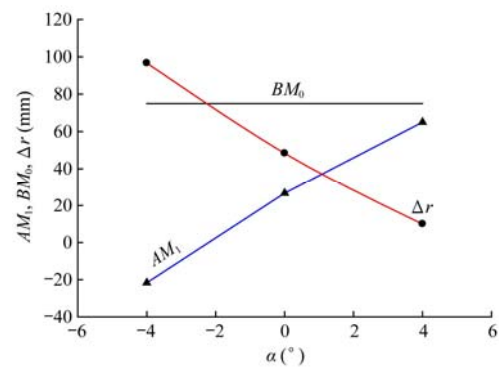

Figure 12 Displacement of the contact point on the stem Δ_r (mm) depending on the slope of the device α at $h_2=0.3$ m, $\lambda=1.2$ and $v_M=0.33$ m s $^{-1}$

The coincidence between theoretical and field results for the stem's slope at the moment of cutting is not as good as for the displacement of the contact point. At $\lambda = 1.2$ and $\alpha = 4^\circ$ the theoretical slope of stem is 25.0° but the actual average is 33.2° . This is a difference of 24.5%, which is explained by the way the stem bends. It does not rotate about the boundary point with the soil surface, as accepted in the theoretical studies. In fact, the stem bending increases in height and at raising the contact point with the finger. Consequently, the prerequisites for

simplifying the theoretical examinations should not be applied to determine the slope of the stem at the time of its shear.

4 Conclusions

A technological scheme and the basic parameters of a new finger device for feeding sesame plants into the harvesting machine at reduced seed scattering has been given proof. The operation of the device requires minimizing the displacement of the contact point between the finger of device and the plant. Besides, it is necessary to tilt the stem over the device to collect the seeds leaving the capsules during it is cutting off from the root. These requirements are achieved through adjusting the longitudinal slope of the device from 0° to 10° and the kinematic factor of the chain - fingers conveyors from 1.1 to 1.5. In this case, the displacement of contact point on the plant is shorter than the length of a capsule, which reduces the risk of wedging the fingers in the central stem during its tilting over the device.

The slope of the stem in the moment of cutting from the root depends on the height of the conveyors to the soil surface and on the distance of blade to the point of initial contact between the plant and fingers. Ensuring a sufficient slope of stem is conducted by adjusting the mentioned distance of the blade from 0.05 to 0.30 m;

The theoretical and the field results deviate acceptable for the displacement of contact point along the stem. They differ significantly for the slope of stem at the moment of cutting off, due to the accepted prerequisites for simplifying the theoretical study. However, the expressions obtained can be used to determine the basic parameters of a new finger device for feeding sesame stems into harvesting machine. Besides that, the optimal

values of the forward velocity, kinematic factor and longitudinal slope of the device must also be determined depending on the particular operating conditions. These results are necessary for manufacturing an one-row harvesting machine and a many-row sesame header to link with the grain harvester.

References

- Ishpekov, S., N. Naydenov, R. Zaykov, S. Stamatov, and D. Rushev. 2017. Releasing of seeds by a lateral mechanical impact for feeding sesame stems into harvester. *Agricultural Engineering International: CIGR Journal*, 19(4): 54–60.
- Ishpekov, S., P. Petrov, R. Zaykov, and N. Naydenov. 2018. Finger device for feeding sesame plants into harvester. Patent pending. (In Bulgarian).
- Langham, D. R., J. Riney, J. Aubin, D. Peeper, T. Spees, G. Smith, and T. Wiemers. 2008. Sesame Harvest Guide. Available at: www.sesaco.net. Accessed 23 April.
- Langham, D. R. 2014. Method for mechanical harvesting of improved non-dehiscent sesame. USA Patent No. 08656692 (In USA).
- Leffel, L. E., and G. Rick. 1988. Air seal for preventing seed loss in crop pickup mechanism. USA Patent No. 4730444 (In USA).
- Naydenov, N., S. Ishpekov, and R. Zaykov. 2016. Opportunities for mechanical feeding of sesame plants in harvesting machine. *Proceedings of University of Ruse*, 55, 27–33. book 1.1., (BG)
- Stamatov, St. and M. Deshev. 2018. Review of the methods for breeding of sesame varieties (*sesamum indicum* L.) in Bulgaria. *Bulgarian Journal of Agricultural Science*, 24(3): 411–416.
- Trifonov, A., P. Petrov, S. Ishpekov, S. Georgiev, S. Stamatov, and M. Deshev. 2014. Harvesting sesame with a combine harvester in the conditions of Bulgaria. *Mechanizacia na zemedeliето*, (1), 13–16, Sofia, (in Bulgarian).
- Zareei, S., and S. Abdollahpour. 2016. Modeling the optimal factors affecting combine harvester header losses. *CIGR Journal*, 18(2): 60–65.
- Statistica, www.statsoft.com