

Electrical properties of maize kernels contaminated with aflatoxin

Francis Collins Muga^{1*}, Tilahun Seyoum Workneh¹, Moses Okoth Marenya^{2,3}

(1. Department of Bioresources Engineering, School of Engineering, University of KwaZulu-Natal, Private Bag X01, Pietermaritzburg, South Africa;

2. Department of Agricultural and Rural Engineering, School of Agriculture, University of Venda, Private Bag X5050, Thohoyandou, South Africa;

3. Institute for Agricultural Engineering, Agricultural Research Council, Private Bag X519, Silvertown, Pretoria, South Africa)

Abstract: The purpose of this study was to investigate the effect of aflatoxin contamination on the dielectric constant of maize kernels. A factorial experiment comprising of three levels of moisture content (13.3%, 15.3%, and 16.4%), three frequencies (25, 50, and 100 kHz), and nine levels of aflatoxin contamination (0, 1.5, 2.6, 10, 50, 100, 150, 172, and 230 $\mu\text{g kg}^{-1}$) was used. The maize kernels were poured into a custom-built sample holder comprising a shielded parallel plate capacitor. An ISO-TECH LCR-821 meter was used to measure the capacitance, from which the dielectric constant was computed. The results indicated that moisture content and frequency significantly ($p \leq 0.05$) affected the dielectric constant. The dielectric constant increased with increase in moisture content and decreased with increasing frequency. However, aflatoxin contamination level had no significant ($p > 0.05$) effect on the dielectric constant of maize kernels. The coefficient of determination (R^2) of dielectric constant and aflatoxin contamination levels was low ($R^2 = 0.2687$), indicating a poor correlation between the aflatoxin levels and the dielectric constant of maize kernels. Based on the findings, the dielectric constant is unsuitable for predicting the level of aflatoxin contamination in maize kernels within the 20-200 kHz frequency range.

Keywords: aflatoxin, capacitance, dielectric constant, maize kernels

Citation: Muga, F. C., T. S. Workneh, and M. O. Marenya. 2018. Electrical properties of maize kernels contaminated with aflatoxin. *Agricultural Engineering International: CIGR Journal*, 20(2): 197–205.

1 Introduction

Aflatoxin is a highly potent carcinogen and has severe health impacts in humans and animals (Wu and Guclu, 2012). Maize, being an important staple for a vast majority of people in Sub-Saharan Africa (Wariboko and Ogidi, 2014), is a principal source of human exposure to aflatoxin (Strosnider et al., 2006; Liu and Wu, 2010). Many nations have, therefore, set regulatory limits on the level of aflatoxin allowed in food, hence the need for aflatoxin detection and quantification methods (Wu and Guclu, 2012; Gnonlonfin et al., 2013).

Screening and analytical methods have been developed to ascertain the levels of aflatoxin in maize.

Chromatographic techniques are the most common analytical methods used for aflatoxin analysis (Shephard, 2009). However, they are time-consuming and involve cumbersome sample preparation (Wacoo et al., 2014). Rapid screening techniques are immunoassay based methods that offer quick, qualitative aflatoxins analysis. Nonetheless, precise amounts of aflatoxin must always be confirmed by an analytical method. Both chromatographic and immunoassay methods involve laboratory-based chemical analyses that require huge capital investments (Wacoo et al., 2014).

Spectroscopic techniques such as fluorometry, near-infrared reflectance (NIR), hyperspectral imaging, and Fourier transform infrared spectroscopy (FTIR), can provide qualitative and quantitative information on mycotoxin contamination with minimal sample preparation and pretreatment (Del Fiore et al., 2010; Lee et al., 2014). However, difficulties with the interpretation of the spectral data and spectral overlapping have limited

Received date: 2017-08-17 Accepted date: 2018-06-29

* Corresponding author: Francis Collins Muga, Department of Bioresources Engineering, University of KwaZulu-Natal, 3209 South Africa. Email: 215081106@stu.ukzn.ac.za or Seyoum@ukzn.ac.za. Tel: +27 033 260 6140, Fax: +27 033 260 5818.

the application of spectroscopic technology in mycotoxin detection and quantification (Lee et al., 2014).

The currently used methods for aflatoxin analysis are inaccessible to small-scale farmers who are the majority producers of maize in Sub-Saharan Africa (Wacoo et al., 2014). Most of the maize produce from small-scale farmers are for subsistence, thus not subjected to quality analysis (Wu and Guclu, 2012). Consequently, it is vital to develop portable devices that can be used in far-flung rural areas to provide quick and accurate aflatoxin analysis (Del Fiore et al., 2010).

Electrical properties of grains have traditionally been used to develop portable devices that give quick quality estimates of cereal grains (Nelson, 2010). The electrical properties of grains are best represented by their dielectric properties (Skierucha et al., 2012). Several researchers (Sosa-Morales et al., 2010; Trabelsi and Nelson, 2012; Torrealba-Meléndez et al., 2015; Noreña and Lescano-Anadón, 2017) have reported quality parameters of agricultural products based on their dielectric properties. In cereals, dielectric properties have mostly been used in moisture content determination (Nelson and Trabelsi, 2012a). Other applications of dielectric properties in cereals include dielectric drying (Zhu et al., 2012), bulk density measurement (Trabelsi et al., 1998), prediction of grain damage levels (Al-Mahasneh et al., 2001), and the control of pest in stored grains (Jiao et al., 2011).

The dielectric properties of grains at a given frequency are affected by moisture content, bulk density and temperature (Jha et al., 2011; Nelson and Trabelsi, 2012). Chemical composition can also affect the dielectric properties (Zhang et al., 2007). Attempts to relate the weighted averages of the dielectric properties of the individual chemical components to the overall dielectric properties of food have so far not been successful (Bhargava et al., 2013). Nonetheless, Sahin and Sumnu (2006) reported that physical changes that affect the proximate composition such as moisture loss and protein denaturation, have an impact on the dielectric properties.

Maize kernels are susceptible to fungal attack, particularly *Aspergillus flavus* (*A. flavus*), which causes aflatoxin and grain deterioration. Fungal growth in stored grains can lead to losses in carbohydrates, proteins, and

total oil content while increasing moisture content and free fatty acids (Begum et al., 2013). It was hypothesized that changes in the chemical composition affect the dielectric properties of maize. Consequently, the dielectric properties can be used to detect the presence and predict the level of aflatoxin contamination in maize kernels. Therefore, the aim of the study was to investigate the effect of the level of aflatoxin contamination on the dielectric properties of maize kernels.

2 Materials and methods

2.1 Inoculum preparation

A. flavus fungal strain was obtained from the Department of Plant Pathology, School of Agricultural, Earth and Environmental Sciences, University of KwaZulu-Natal, South Africa. The fungus was plated on potato dextrose agar (Merk, Darmstadt, Germany) at 25°C for five days after which the conidia was harvested by flooding a single culture with distilled water and scraping the surface mycelia with a sterile scraper. The resulting suspension was filtered through a cheesecloth to obtain a pure spore suspension. The spore suspension was then adjusted to 4×10^6 cells mL⁻¹ using a Neubauer hemocytometer to make the inoculum (Hruska et al., 2014).

2.2 Preparation and inoculation of maize samples

White maize variety SC411, obtained from Seed Co Pty Ltd (South Africa) was used in the study. The initial moisture content of the maize was 12.19% ± 0.10% (w.b). A total of 30 samples of maize kernels each of mass 4 kg were prepared. The maize samples were surface sterilised by immersing the kernels in a 5% (v/v) sodium hypochlorite (NaClO) solution and stirring for one minute then rinsed twice with distilled water. The moisture content of the maize kernels was adjusted to 17% (w.b) by soaking the samples in distilled water for 2 hours. The samples were then put in sterilized plastic bags, sealed and placed inside a refrigerator set at 4°C for 72 hours to ensure uniform moisture distribution.

The maize samples were retrieved from the refrigerator and allowed to equilibrate to room temperature. 5 mL of *A. flavus* inoculum and distilled water (control), was sprinkled on the samples and mixed manually before being transferred to the incubator. The

samples were incubated at a temperature of 28°C for a predetermined length of time *viz.*, 0, 7, 14, 21, and 28 days. The samples were removed from the incubator at the end of the incubation period and analysed for aflatoxin contamination. A full factorial design comprising of two factors (inoculum and incubation period) was used in this experiment.

2.3 Aflatoxin analysis

Aflatoxin analysis was done using a liquid chromatography-tandem mass spectroscopy (LC-MS/MS) as outlined in Waters (2007). 250 g of each sample was ground using a Retsch Rotor Mill (SK 1, Germany). 25 g of the ground maize sample was mixed with 80 mL of acetonitrile and 20 mL of water and left to stand for 2 hours. The extract was filtered and diluted four-times with distilled water. 20 µL of the diluted extract was fed into the LC-MS/MS for analysis. The liquid chromatography (LC) had an acuity, ultra-performance liquid chromatography, ethyle bridge hybrid column (UPLC BEH C18 1.7 µm; 2.1×100 mm column). The mobile phase A and mobile phase B was 0.1% formic acid in water and 0.1% formic acid in acetonitrile respectively. The LC flow rate was 0.4 mL min⁻¹. The eluent from the LC column was directed to the mass spectrometer. The electrospray source was operated in a positive ionisation multiple reaction monitoring (MRM) mode. The data acquired was analysed using Waters Masslynx™ software. The limit of detection for the LC-MS/MS was 0.5 µg kg⁻¹, whereas the quantification limit was 2 µg kg⁻¹.

2.4 Sample preparation for electrical properties measurement

From the aflatoxin analysis results, nine samples were selected for the measurement of electrical properties. The levels of aflatoxin contamination for the nine samples were 0, 1.5, 2.6, 10, 50, 100, 150, 172, and 230 µg kg⁻¹. The moisture content (m.c.) of the samples was determined by oven drying at 105°C for 24 hours. The samples were thereafter dried in the oven at 55°C to obtain three distinct levels of m.c. (16.4%, 15.4%, and 13.3% w.b.). A calculated amount of water (Equation (1)) was added to the samples where necessary. The samples were then put in Ziploc bags and refrigerated at 4°C for 72 hours before electrical properties' measurement. The

bags were shaken manually at least three times a day to ensure a uniform m.c.

$$M_w = M_m ((1 - MC_i) / (1 - MC_f)) - M_m \quad (1)$$

where, M_w is the mass of water needed (kg); M_m is the mass of maize kernels in (kg); MC_i is the initial moisture content (%), and MC_f is the target moisture content (%).

2.5 Dielectric constant measurement

The dielectric constant was evaluated from capacitance measurements using Equation (2).

$$\epsilon' = C / C_o \quad (2)$$

where, ϵ' is the dielectric constant; C is the capacitance of sample holder filled with maize (pF), and C_o is the capacitance of empty sample holder (pF).

The measurement system consisted of a sample holder connected to an LCR meter. The sample holder was a custom-built, shielded parallel plate electrode assembly (Figure 1) as outlined by Lawrence et al. (1998). The sample holder had three aluminium plate electrodes each measuring 17.5×15 cm and 0.5 cm thick. The electrode spacing was 2.5 cm. The plate electrodes were attached to two 7.6×30.5×1.9 cm vertical support made from Perspex. The electrodes were fitted into 15 cm long, 1.27 cm deep grooves on the support members. The supports were screwed to an aluminium base plate measuring 15.3×25.4×0.6 cm. Perspex plate of dimensions 15.88×10.16×0.6 cm was used to seal the bottom of the electrode chamber by sliding it into grooves made on the Perspex supports. The total volume of the electrode chamber was 1143 cm³. A type N to APC-7 adaptor was attached to the middle electrode and used to connect the sample holder to the LCR meter through a 50 Ω coaxial cable.

The capacitance measurements were done using an ISO-TECH LCR-821 meter. The ISO-TECH LCR-821 meter has five full digit resolutions for inductance (L), capacitance (C), resistance (R) and absolute value of impedance (Z), with an accuracy range of 0.1%. The frequency range of the ISO-TECH LCR-821 meter is between 12 Hz and 100 kHz.

2.6 Experimental procedure

The selected maize samples were retrieved from the refrigerator and allowed to equilibrate to room temperature for 6 hours. The LCR meter was then calibrated through open and short calibrations. Thereafter,

the LCR meter was connected to the sample holder using a 50 Ω coaxial cable. The measurement frequency was set at 25 kHz and the capacitance measurements of the empty sample holder recorded as C_o . Maize samples at a m.c. of 13.3%, and aflatoxin contamination levels of 0, 1.5, 2.6, 10, 50, 100, 150, 172, and 230 $\mu\text{g kg}^{-1}$ were poured into the sample holder, one at a time and the new capacitance, C , recorded. The same procedure was followed when the m.c. of the maize samples was adjusted to 15.4% and 16.4%. The measurement frequency was adjusted to 50 kHz and 100 kHz and the entire procedure repeated each time.

2.7 Experimental design and data analysis

The experiment was designed as a 3×3×9 factorial experiment. The three factors were m.c. (13.3%, 15.4%, and 16.4%), frequency (25, 50, and 100 kHz), and aflatoxin level (0, 1.5, 2.6, 10, 50, 100, 150, 172, and 230 $\mu\text{g kg}^{-1}$). All the treatments were replicated three times. Statistical analysis was done using GenStat® 17th Edition (VSN International Ltd, Hemel Hempstead, United Kingdom). Analysis of variance (ANOVA) was done at 5% level of significance. Regression analysis was done to determine the correlation between dielectric properties and aflatoxin contamination.

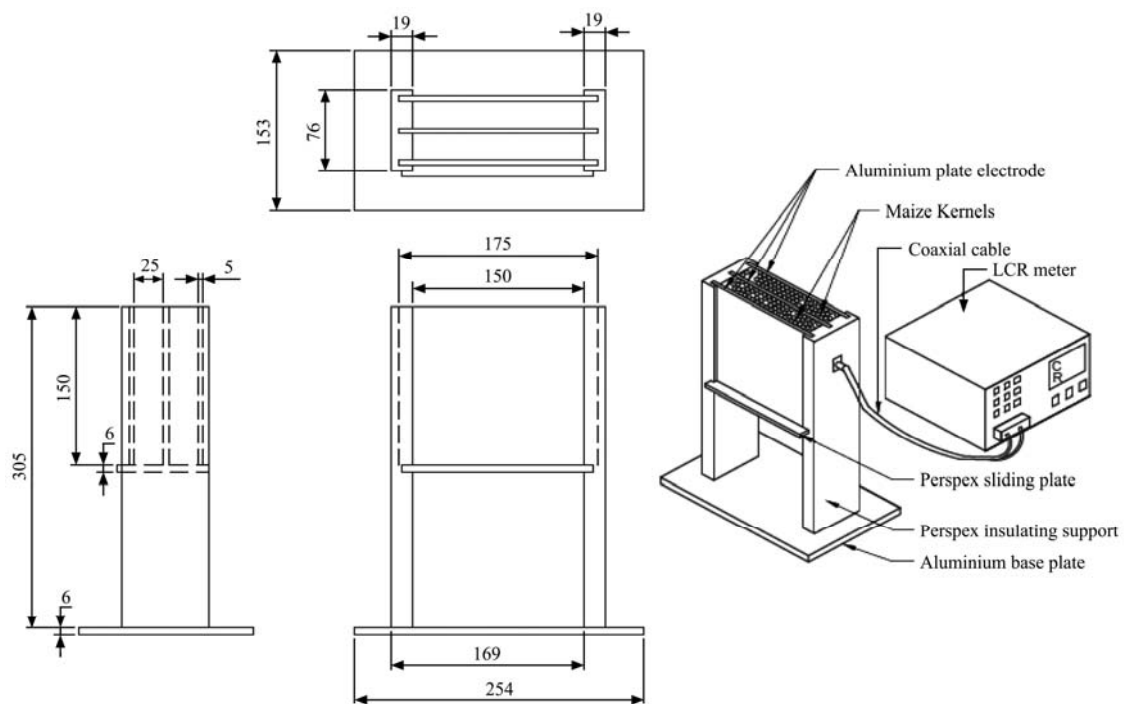

Figure 1 A modified custom-built shielded parallel plate electrode sample holder connected to an LCR meter

3 Results

3.1 Aflatoxin Contamination

There was no aflatoxin detected in the samples before incubation (day 0). Aflatoxin (AFB1) contamination increased as incubation period increased. The samples inoculated with distilled water showed no aflatoxin

contamination at the end of day seven. The mean AFB1 contamination level observed on day 14 was 2.1 $\mu\text{g kg}^{-1}$, rising to 27.4 $\mu\text{g kg}^{-1}$ and 130.6 $\mu\text{g kg}^{-1}$ on day 21 and day 28 respectively. The maize kernels inoculated with *A. flavus* resulted in AFB1 contamination levels ranging from 270.5 $\mu\text{g kg}^{-1}$ on day 7 to 12907.8 $\mu\text{g kg}^{-1}$ on day 28 (Table 1).

Table 1 Aflatoxin (AFB1) contamination

Innoculum	Time (day)	Distilled water					<i>A. flavus</i>				
		0	7	14	21	28	0	7	14	21	28
AFB1 ($\mu\text{g kg}^{-1}$)	Rep 1	nd	nd	1.5	21.2	141.1	nd	409.1	1259.8	3032.2	10508.2
	Rep 2	nd	nd	2.6	50.1	100.6	nd	172.3	1628.6	2806.3	15257.8
	Rep 3	nd	nd	2.1	10.4	150.0	nd	230.2	1082.1	5024.0	12957.3
Average		-	-	2.1	27.4	130.6	-	270.5	1323.5	3620.9	12907.8
Standard Deviation		-	-	0.4	27.8	35.0	-	40.9	386.4	1568.1	1626.7

Note: nd = not detected

3.2 Effect of moisture content on the dielectric constant

The dielectric constant was calculated from the capacitance values using Equation (2). The dielectric constant ranged between 2.06-4.48 at 13.3% m.c., 3.28-8.16 at 15.4% m.c., and 4.47-12.66 at 16.4% m.c. (Table 2). At a given frequency and aflatoxin level, the dielectric constant increased with increase in m.c. Consequently,

the greatest increase was observed at a m.c. of 16.4%. Therefore, m.c. significantly ($p \leq 0.05$) influenced the dielectric constant. At every m.c. level, the rate of increase in dielectric constant was greater at lower frequencies than at higher frequencies. There were significant differences between the mean dielectric constant at different m.c. levels as indicated by the results from Duncan's multiple range test (Table 2).

Table 2 Dielectric constant of maize kernels at a specified level of aflatoxin, frequency and m.c. (w.b.)

Freq (kHz)	m.c. (%)	Dielectric constant (ϵ')								
		0 $\mu\text{g kg}^{-1}$	1.5 $\mu\text{g kg}^{-1}$	2.6 $\mu\text{g kg}^{-1}$	10 $\mu\text{g kg}^{-1}$	50 $\mu\text{g kg}^{-1}$	100 $\mu\text{g kg}^{-1}$	150 $\mu\text{g kg}^{-1}$	172 $\mu\text{g kg}^{-1}$	230 $\mu\text{g kg}^{-1}$
25	13.3	4.26 ^{vwx}	4.48 ^{stuv}	4.35 ^{uv}	4.03 ^{wxy}	4.01 ^{xy}	4.39 ^{uv}	4.38 ^{uv}	4.28 ^{vwx}	3.80 ^{yz}
	15.4	6.30 ^{jk}	8.16 ^g	7.25 ^h	5.76 ^{mn}	6.66 ⁱ	5.96 ^{lm}	7.21 ^h	6.05 ^{kl}	6.23 ^{kl}
	16.4	10.92 ^c	12.66 ^a	12.55 ^a	9.57 ^e	9.32 ^{ef}	10.16 ^d	11.90 ^b	9.13 ^f	9.52 ^e
50	13.3	3.27 ^{CDE}	3.58 ^{zAB}	3.25 ^{CDE}	3.11 ^{DEF}	3.07 ^{EF}	3.32 ^{BCDE}	3.53 ^{ABC}	3.49 ^{BC}	2.85 ^F
	15.4	4.82 ^{qrs}	6.11 ^{kl}	5.18 ^{op}	4.37 ^{uvw}	5.03 ^{pq}	4.53 ^{uv}	5.60 ⁿ	4.51 ^{uv}	4.71 ^{rst}
	16.4	7.42 ^h	8.29 ^g	8.30 ^g	6.63 ^{ij}	6.24 ^{kl}	7.17 ^h	8.47 ^g	6.83 ⁱ	6.39 ^{jk}
100	13.3	2.53 ^G	2.45 ^G	2.29 ^{GH}	2.33 ^{GH}	2.26 ^{GH}	2.44 ^G	2.42 ^G	2.43 ^G	2.06 ^H
	15.4	3.43 ^{BCD}	4.32 ^{vwx}	3.58 ^{ABC}	3.36 ^{BCDE}	3.67 ^{zAB}	3.29 ^{CDE}	3.86 ^{yzA}	3.43 ^{BCD}	3.28 ^{CDE}
	16.4	5.38 ^o	5.82 ^{mn}	5.81 ^{mn}	5.11 ^{opq}	4.71 ^{rstu}	5.36 ^{op}	5.78 ⁿ	4.94 ^{qr}	4.47 ^{uv}
Source of variation		d.f.		s.s.		m.s.		v.r.		F pr.
Replications stratum		2		0.04711		0.02356		1.35		
Replications.*Units* stratum										
Aflatoxin		8		52.09768		6.51221		372.99		0.198
Frequency		2		479.61414		239.80707		13734.89		<0.001
MC		2		830.79157		415.39579		23791.68		<0.001
Aflatoxin.Frequency		16		11.99236		0.74952		42.93		0.198
Aflatoxin.MC		16		27.46895		1.71681		98.33		0.066
Frequency.MC		4		87.45533		21.86383		1252.25		<0.001
Aflatoxin.Frequency.MC		32		9.59212		0.29975		17.17		0.067
Residual		160		2.79355		0.01746				
Total		242		1501.85283						

LSD_{p<0.05} = 0.546 CV = 0.041

Note: Means within a column followed by the same letter(s) are not significantly different according to Duncan's multiple range test ($P < 0.05$).

3.3 Effect of frequency on the dielectric constant

The frequency dependence of the dielectric constant of maize kernels as a function of aflatoxin level and m.c. is shown in Figures 2 (a), (b), and (c). The frequency significantly ($p \leq 0.05$) affected the dielectric constant of the maize kernels at the three different m.c. and aflatoxin contamination levels. The dielectric constant decreased with increase in frequency. The rate of decrease of dielectric constant was greater at lower frequencies than at higher frequencies. The effect of frequency on the dielectric constant was pronounced at higher m.c. than at lower m.c. The biggest change in dielectric constant was observed at 25 kHz, ranging between 3.80 and 12.66;

whereas the least change in dielectric constant was observed at 100 kHz, in the range of 2.06-5.82. The dielectric constant at 50 kHz was in the range of 2.85-8.30 (Table 2).

3.4 Effect of aflatoxin on the dielectric constant

The dielectric constant decreased with frequency and increased with m.c., but there was no noticeable trend due to aflatoxin contamination level. The level of aflatoxin contamination had no significant ($p > 0.05$) effect on the dielectric constant of the maize kernels across all treatments. The dielectric constant for the maize kernels with a m.c. of 13.3 and 16.4% was relatively stable at a given frequency across all the levels of aflatoxin

contamination. The dielectric constant for the maize kernels with a m.c. of 15.4% kept fluctuating as the level of aflatoxin contamination increased (Figure 3). Maize kernels with aflatoxin contamination level of 0, 1.5, and

$2.6 \mu\text{g kg}^{-1}$ had relatively higher dielectric constant values, while maize kernels with aflatoxin contamination level of 172 and $230 \mu\text{g kg}^{-1}$ had the lowest dielectric constant values.

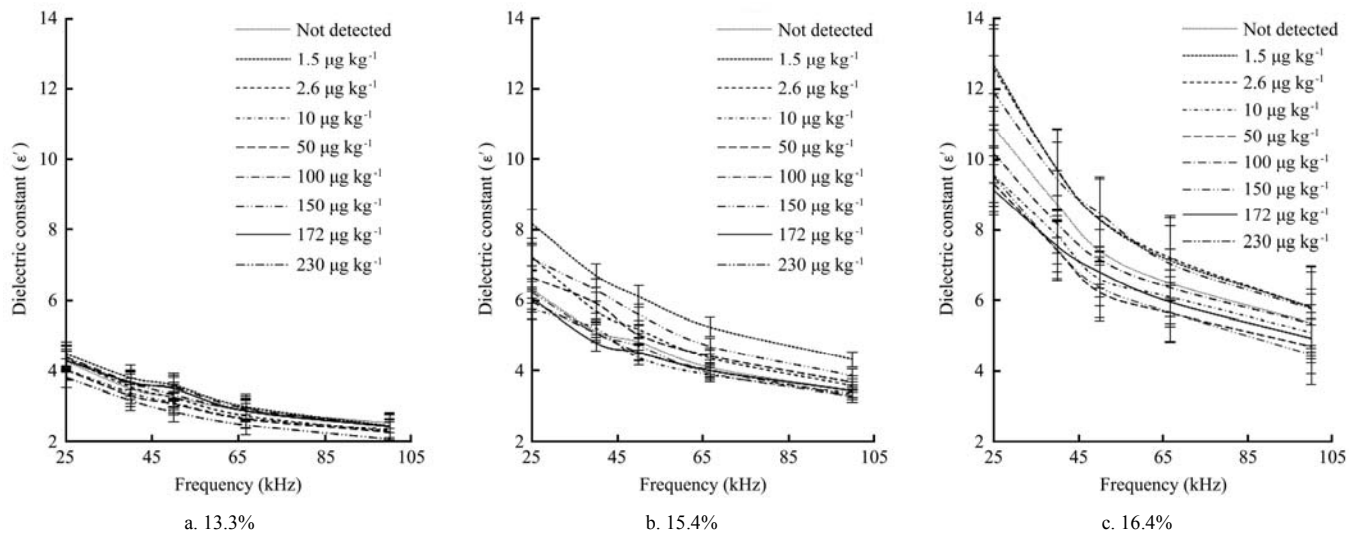

Figure 2 Variation of dielectric constant with frequency at specified aflatoxin levels for maize kernels at m.c. (w.b) ($\text{LSD}_{p<0.05} = 0.3154$, $\text{CV} = 0.014$)

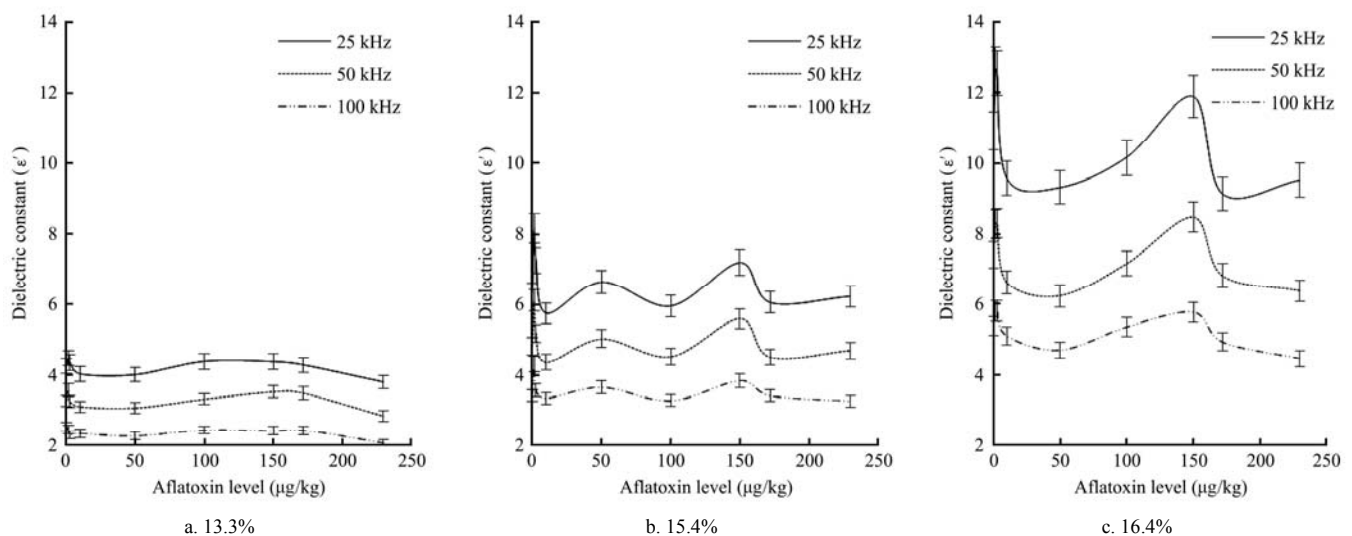

Figure 3 Variation of dielectric constant with aflatoxin contamination at specified frequencies for maize kernels at m.c. (w.b) ($\text{LSD}_{p<0.05} = 0.3154$, $\text{CV} = 0.014$)

Results from a linear regression analysis of dielectric constant against aflatoxin contamination level showed very low coefficient of determination (R^2) values. The highest value for the coefficient of determination ($R^2 = 0.2687$) was at 100 kHz at a m.c. of 16.4%, whereas the lowest coefficient of determination ($R^2 = 0.0300$) was at 50 kHz and 13.3% m.c. The low coefficient of determination (R^2) values indicate a very weak correlation between dielectric constant and aflatoxin contamination level. At all frequency and m.c. levels, aflatoxin had no significant effect ($p > 0.05$) on dielectric constant.

4 Discussion

Maize kernels are susceptible to fungal attack, particularly *A. flavus*, which cause aflatoxin contamination and grain deterioration. The AFB1 contamination increased over time because of the increase in fungal population. *A. flavus* grows faster at the incubation temperature of 28°C (Garcia et al., 2012; Pratiwi et al., 2015). AFB1 contamination observed in the maize kernels inoculated with distilled water could have been caused by internal infection (Mellon et al., 2007).

According to Begum et al. (2013), fungal growth in grains depletes the carbohydrates, proteins and total oil content while increasing moisture content and free fatty acids.

The m.c. of the maize kernels significantly ($p \leq 0.05$) affected the dielectric constant across all treatments. This is in agreement with Soltani and Alimardani (2011) who reported an increase in the dielectric constant of maize grains with increasing m.c. Nelson and Trabelsi (2012b) and Noreña and Lescano-Anadón (2017) also reported similar results on maize and wheat, and sorghum respectively. Moisture content is the most important factor that influences the dielectric constant of maize (Shrivastava et al., 2014). According to Singh et al. (2010), m.c. increases the dipoles in a material promoting total polarisation of the material. Wang et al. (2013) attribute the progressive increase in dielectric constant with increase in m.c. to the transition of bound water state from monolayer or multilayer to free water state. At a m.c. of 13.3%, most of the water is bound to the protein or starch, reducing the free water within the maize kernel, hence low values of dielectric constant at this level of m.c. The high m.c. of 16.4% increases the proportion of free water within the maize kernels leading to more water dipoles which contribute to polarisation hence higher values of dielectric constant.

Besides m.c., the frequency of the electrical signal significantly ($p \leq 0.05$) influenced the dielectric constant of the maize kernels. The findings from this study agree with those reported by Sacilik and Colak (2010) on maize kernels, Tomaraei (2010) on wheat, and Karjilova et al. (2013) on spelled grains. The frequency dependence of dielectric constant is also attributed to the polarisation of molecules with permanent dipole moments within the maize kernel. Polarisation follows the alteration of the electric field without any lag at low frequencies, hence larger dielectric constant values. The orientation of the dipoles cannot keep up with the rapid field reversals at higher frequencies resulting in low dielectric constant as the signal frequency increases (Nelson and Trabelsi, 2012b).

The level of aflatoxin contamination had no significant ($p > 0.05$) effect on the dielectric constant of the maize kernels. The dielectric constant fluctuated with

an increase in the level of aflatoxin contamination. These fluctuations in dielectric constant can be attributed to the small variation in m.c. among the samples. As already discussed, m.c. significantly affects the dielectric constant, and its effects are pronounced at higher m.c. levels. It is evident from Figure 3 that fluctuations in dielectric constant are greater at 16.4% and 15.4% than at 13.3% m.c.

The relatively higher values of dielectric constant for maize kernels with aflatoxin levels of 1.5, and 2.6 $\mu\text{g kg}^{-1}$ and the low values of dielectric constant for maize kernels with aflatoxin level of 172 and 230 $\mu\text{g kg}^{-1}$, could have been caused by the difference in bulk density. The dielectric constant of maize increases with bulk density (Trabelsi et al., 1998). The high aflatoxin contamination of 172 and 230 $\mu\text{g kg}^{-1}$ indicates high *A. flavus* contamination which causes dry matter loss resulting in low bulk density. The maize kernels with aflatoxin contamination of 1.5, and 2.6 $\mu\text{g kg}^{-1}$ undergo minimal dry matter loss due to low contamination with *A. flavus*, thus a relatively higher bulk density.

Aflatoxin content in the grain kernel constitutes an insignificant proportion of the total maize composition. However, *A. flavus* significantly degrades the fat, protein and carbohydrate, besides producing aflatoxin. Aflatoxin contamination positively correlates to changes in the proximate composition of maize. Some researchers (Ryynänen, 1995; Ndife et al., 1998; Sahin and Sumnu, 2006; Zhang et al., 2007) have reported that chemical composition influences the dielectric properties. Nonetheless, the changes in chemical composition of the maize kernels, associated with aflatoxin contamination had no impact on the dielectric constant of the maize kernels. This may be so because fats, proteins and carbohydrates have a low dielectric constant and their effect on the overall dielectric constant of the maize kernels was overshadowed by the effect of m.c. on the same as suggested by Nelson (1982).

5 Conclusion

The dielectric constant of maize kernels is significantly ($p \leq 0.05$) affected by the moisture content and the frequency. The dielectric constant is directly related to moisture content and inversely related to

frequency. Aflatoxin contamination, however, does not have any significant ($p>0.05$) influence on the dielectric constant of maize kernels. The coefficient of determination (R^2) of dielectric constant and aflatoxin contamination levels was low (0.03-0.2687), which indicate a lack of correlation between the aflatoxin levels and dielectric constant of the maize kernels. These findings imply that the dielectric constant of maize kernels is unsuitable for predicting the degree of aflatoxin contamination in maize kernels within the 20-200 kHz frequency range. This study, therefore, recommends further research using higher frequencies.

References

- Al-Mahasneh, M. A., S. J. Birrell, C. J. Bern, and K. Adam. 2001. Measurement of corn mechanical damage using dielectric properties. In *Proc. 2001 ASAE Annual International Meeting*, 1073–1080. Sacramento, C.A., 28 July-1 August.
- Begum, A., B. Venudevan, and M. Jayanthi. 2013. Storage fungi in groundnut and the associate seed quality deterioration-A Review. *Plant Pathology Journal*, 12(3): 127–134.
- Bhargava, N., R. Jain, I. Joshi, and K. Sharma. 2013. Dielectric properties of cereals at microwave frequency and their biochemical estimation. *International Journal of Science, Environment*, 2(3): 369–374.
- Del Fiore, A., M. Reverberi, A. Ricelli, F. Pinzari, S. Serranti, A. Fabbri, G. Bonifazi, and C. Fanelli. 2010. Early detection of toxigenic fungi on maize by hyperspectral imaging analysis. *International Journal of Food Microbiology*, 144(1): 64–71.
- Garcia, D., G. Barros, S. Chulze, A. J. Ramos, V. Sanchis, and S. Marin. 2012. Impact of cycling temperatures on *Fusarium verticillioides* and *Fusarium graminearum* growth and mycotoxins production in soybean. *Journal of the Science of Food and Agriculture*, 92(15): 2952–2959.
- Gnonlonfin, G. J. B., K. Hell, Y. Adjovi, P. Fandohan, D. Koudande, G. Mensah, A. Sanni, and L. Brimer. 2013. A Review on aflatoxin contamination and its implications in the developing world: a sub-Saharan African perspective. *Critical Reviews in Food Science and Nutrition*, 53(4): 349–365.
- Hruska, Z., K. Rajasekaran, H. Yao, R. Kinkaid, D. Darlington, R. L. Brown, D. Bhatnagar, and T. E. Cleveland. 2014. Co-inoculation of aflatoxigenic and non-aflatoxigenic strains of *Aspergillus flavus* to study fungal invasion, colonization, and competition in maize kernels. *Frontiers in Microbiology*, 5(4): 122–130.
- Jha, S. N., K. Narsaiah, A. Basediya, R. Sharma, P. Jaiswal, R. Kumar, and R. Bhardwaj. 2011. Measurement techniques and application of electrical properties for nondestructive quality evaluation of foods—A Review. *Journal of Food Science and Technology*, 48(4): 387–411.
- Jiao, S., J. Johnson, J. Tang, G. Tiwari, and S. Wang. 2011. Dielectric properties of cowpea weevil, black-eyed peas and mung beans with respect to the development of radio frequency heat treatments. *Biosystems Engineering*, 108(3): 280–291.
- Karjilova, K., Y. Rangelov, and Z. Hlavacova. 2013. Measurement of the Electrical Properties of Spelled Grains - T. Dicocum. *International Journal of Applied Science and Technology*, 3(7): 118–126.
- Lawrence, K., W. Windham, and S. Nelson. 1998. Wheat moisture determination by 1-to 110-MHz swept-frequency admittance measurements. *Transactions of the ASAE*, 41(1): 135–142.
- Lee, K. M., T. J. Herrman, and U. Yun. 2014. Application of Raman spectroscopy for qualitative and quantitative analysis of aflatoxins in ground maize samples. *Journal of Cereal Science*, 59(1): 70–78.
- Liu, Y., and F. Wu. 2010. Global burden of aflatoxin-induced hepatocellular carcinoma: a risk assessment. *Environmental Health Perspectives*, 118(6): 818–823.
- Mellon, J. E., P. J. Cotty, and M. K. Dowd. 2007. *Aspergillus flavus* hydrolases: their roles in pathogenesis and substrate utilization. *Applied Microbiology and Biotechnology*, 77(3): 497–504.
- Ndife, M., G. Şumnu, and L. Bayindirli. 1998. Dielectric properties of six different species of starch at 2450 MHz. *Food Research International*, 31(1): 43–52.
- Nelson, S. O. 1982. Factors affecting the dielectric properties of grain. *Transactions of the ASAE*, 25(4): 1045–1049.
- Nelson, S. O. 2010. Fundamentals of dielectric properties measurements and agricultural applications. *Journal of Microwave Power and Electromagnetic Energy*, 44(2): 98–113.
- Nelson, S. O., and S. Trabelsi. 2012a. A century of grain and seed moisture measurement by sensing electrical properties. *Transactions of the ASABE*, 55(2): 629–636.
- Nelson, S. O., and S. Trabelsi. 2012b. Factors influencing the dielectric properties of agricultural and food products. *Journal of Microwave Power and Electromagnetic Energy*, 46(2): 93–107.
- Noreña, C. P., and C. E. Lescano-Anadón. 2017. Dielectric properties of importance in operations of post-harvest of sorghum. *International Journal of Food Engineering*, 13(4): 369–375.
- Pratiwi, C., W. P. Rahayu, H. N. Lioe, D. Herawati, W. Broto, and S. Ambarwati. 2015. The effect of temperature and relative humidity for *Aspergillus flavus* BIO 2237 growth and aflatoxin production on soybeans. *International Food Research Journal*, 22(1): 82–87.
- Ryynänen, S. 1995. The electromagnetic properties of food materials: a review of the basic principles. *Journal of Food*

- Engineering*, 26(4): 409–429.
- Sacilik, K., and A. Colak. 2010. Determination of dielectric properties of corn seeds from 1 to 100 MHz. *Powder Technology*, 203(2): 365–370.
- Sahin, S., and S. G. Sumnu. 2006. *Rheological Properties of Foods*. New York, USA: Springer Science and Business Media.
- Shephard, G. S. 2009. Aflatoxin analysis at the beginning of the twenty-first century. *Analytical and Bioanalytical Chemistry*, 395(5): 1215–1224.
- Shrivastava, B., R. Barde, A. Mishra, and S. Phadke. 2014. Dielectric behavior of biomaterials at different frequencies on room temperature. *Journal of Physics: Conference Series*, 534(1): 1–4.
- Singh, S. P., P. Kumar, R. Manohar, and J. Shukla. 2010. Dielectric properties of some oil seeds at different concentration of moisture contents and micro-fertilizer. *International Journal of Agricultural Research*, 5(8): 678–689.
- Skierucha, W., A. Wilczek, and A. Szyplowska. 2012. Dielectric spectroscopy in agrophysics. *International Agrophysics*, 26(2): 187–197.
- Soltani, M., and R. Alimardani. 2011. Prediction of corn and lentil moisture content using dielectric properties. *Journal of Agricultural Technology*, 7(5): 1223–1232.
- Sosa-Morales, M., L. Valerio-Junco, A. López-Malo, and H. García. 2010. Dielectric properties of foods: reported data in the 21st century and their potential applications. *LWT-Food Science and Technology*, 43(8): 1169–1179.
- Strosnider, H., E. Azziz-Baumgartner, M. Banziger, R. V. Bhat, R. Breiman, M. N. Brune, K. DeCock, A. Dilley, J. Groopman, and K. Hell. 2006. Workgroup report: public health strategies for reducing aflatoxin exposure in developing countries. *Environmental Health Perspectives*, 114(12): 1898–1903.
- Tomaraei, P. 2010. Development of RF moisture sensor for measuring moisture content in grain. M.S. thesis. Ankara, Turkey: Dept. of Agricultural Machinery, Ankara University.
- Torrealba-Meléndez, R., M. E. Sosa-Morales, J. L. Olvera-Cervantes, and A. Corona-Chávez. 2015. Dielectric properties of cereals at frequencies useful for processes with microwave heating. *Journal of Food Science and Technology*, 52(12): 8403–8409.
- Trabelsi, S., A. W. Kraszewski, and S. O. Nelson. 1998. Nondestructive microwave characterization for determining the bulk density and moisture content of shelled corn. *Measurement Science and Technology*, 9(9): 1548–1556.
- Trabelsi, S., and S. Nelson. 2012. Microwave dielectric properties of cereal grains. *Transactions of the ASABE*, 55(5): 1989–1996.
- Wacoo, AP, Wendi, D, Vuzi, PC and Hawumba, JF. 2014. Methods for detection of aflatoxins in agricultural food crops. *Journal of Applied Chemistry*, 14: 11–15.
- Wang, Y., L. Zhang, M. Gao, J. Tang, and S. Wang. 2013. Temperature-and moisture-dependent dielectric properties of macadamia nut kernels. *Food and Bioprocess Technology*, 6(8): 2165–2176.
- Wariboko, C., and I. Ogidi. 2014. The performance of some maize (*Zea mays*, L.) varieties in Niger Delta of Nigeria. *Academia Journal of Agricultural Research*, 2(4): 122–127.
- Waters. 2007. Rapid multi-mycotoxin analysis using ACQUITY UPLC and Quattro Premier XE: Waters Application Note 720001996EN. Waters Corporation Database. Milford, Massachusetts: Waters Corporation. Available at http://www.waters.com/waters/library.htm?locale=en_ZA&lid=1512802&cid=511436. Accessed 18 August 2016.
- Wu, F., and H. Guclu. 2012. Aflatoxin regulations in a network of global maize trade. *PloS one*, 7(9): 45–51.
- Zhang, L., J. G. Lyng, and N. P. Brunton. 2007. The effect of fat, water and salt on the thermal and dielectric properties of meat batter and its temperature following microwave or radio frequency heating. *Journal of Food Engineering*, 80(1): 142–151.
- Zhu, X., W. Guo, X. Wu, and S. Wang. 2012. Dielectric properties of chestnut flour relevant to drying with radio-frequency and microwave energy. *Journal of Food Engineering*, 113(1): 143–150.