

# Operations scheduling of sugarcane production using fuzzy GERT method (part II: preserve operations, harvesting and ratooning)

Nasim Monjezi<sup>1\*</sup>, Mohammad Javad Sheikhdavoodi<sup>1</sup>, Hasan Zakidizaji<sup>1</sup>,  
Afshin Marzban<sup>2</sup> and Mahmood Shomeili<sup>3</sup>

(1. Department of Agricultural Machinery, Faculty of Agriculture, Shahid Chamran University, Ahvaz, 6166616453 Iran;

2. Department of Agricultural Machinery, Ramin Agriculture and Natural Resources University, Mollasani 3641773637, Iran;

3. Manager of Agronomy Department in Iranian Sugarcane Research and Training Institute, 6134811169, Iran)

**Abstract:** This paper presents a GERT method based on fuzzy theory for solving fuzzy project scheduling of sugarcane production (preserve operations, harvesting and rationing) in Khuzestan province of Iran. In this method, activity duration time and loops, repetition number, and output activities from nodes of network belong to a fuzzy set. First, an analytical approach was proposed to simplify the structure of network. Then, GERT network computations were done based on evaluating nodes. Process outputs were scheduled network and project fuzzy completion time. These outputs were fuzzy numbers and can be analyzed by  $\alpha$ -cut. Results prove that the method of using fuzzy numbers and fuzzy relation in project scheduling is a powerful tool to estimate time for agricultural mechanization projects.

**Keywords:** scheduling, sugarcane, GERT, fuzzy

**Citation:** Monjezi, N., M. J. Sheikhdavoodi, H. Zakidizaji, A. Marzban, and M. Shomeili. 2016. Operations scheduling of sugarcane production using fuzzy GERT method (part II: preserve operations, harvesting and ratooning). *Agricultural Engineering International: CIGR Journal*, 18(3):343-349.

## 1 Introduction

Graphical Evaluation and Review Technique (GERT) is widely used in project scheduling and controlling. In conventional project scheduling problem, the crisp numbers are used for the activity times. But in reality, in an imprecise and uncertain environment, it is an unrealistic assumption. To represent the uncertainty involved we have considered the interval-valued numbers to represent the activity times. Cheng in his first article introduced the fuzzy GERT method for solving the reliability problem for series systems. In his second article, he presented the capability of repairable systems using fuzzy GERT method (Cheng, 1996; Cheng, 1994).

Itakura and Nishikawa were among the first scientists who utilized fuzzy concepts in GERT networks for project scheduling. In their method, the number of activities outside each node belongs to a fuzzy network. The solution is alike probabilistic GERT method except that min, max functions have been used for fuzzy networks (Itakura and Nishikawa, 1984). Since the efficiency and capabilities of Graphical Evaluation and Review Technique (GERT) networks for modeling, simulation, planning, scheduling and analysis of the projects in complicated systems had been proved and confirmed in different fields of industry (Matsumoto et al., 2007; Takanobu et al., 2004; Ahcom, 2004; Gauri, 2003; Kenzo and Nobuyuki, 2002; Gauri and Vandana, 2000; Kahalzadeh, 2000). Also, the planning and project controlling techniques, especially network models, have been used in agricultural projects (Monjezi et al., 2012a, b; Abdi et al., 2010; Abdi et al., 2009; Fahimifard and

**Received date:** 2015-10-25

**Accepted date:** 2015-11-05

**\*Corresponding author:** Nasim Monjezi, Department of Agricultural Machinery, Faculty of Agriculture, Shahid Chamran University, Ahvaz, Iran. E-mail Address: N-monjezi@phdstu.scu.ac.ir.

Kehkha, 2009). In this research, GERT Networks were used and operations scheduling of sugarcane production (preserve operations, harvesting and ratooning) in Khuzestan province of Iran as a case study was analyzed.

**Fuzzy GERT network**

Fuzzy GERT network is the same probability GERT network that fuzzy parameters have replaced probability parameters and were composed from three parts: logical nodes, fuzzy branches and loops. Logical nodes in fuzzy GERT network were the same probability GERT network that contains output and input side. Input side was being the same probability GERT network which contains three kinds “EXCLUSIVE OR”, “INCLUSIVE OR” and “AND”, and output side was being contained two kinds of deterministic and fuzzy output that are being defined below (Table 1).

**Table 1 All input and output relations for nodes**

Input side	Exclusive-OR 	AND 	Inclusive-OR 
Output side	Deterministic 	Probabilistic 	

Different combinations of nodes (Figure 1):

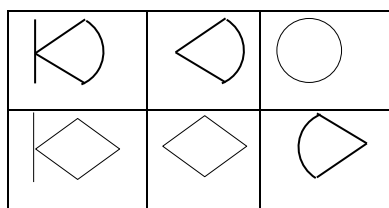

Figure 1 Six possible combinations for nodes

In this network, fuzzy branch is replaced probability branch. Each branch is characterized with membership degree  $\mu_{ij}$  and fuzzy duration time ( $\tilde{t}_{ij}$ ) (Figure 2).

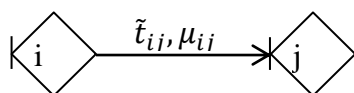

Figure 2 Fuzzy branch

Loops are activities that are repeated for one or more times. Each loop is characterized with membership degree or occurrence possibility ( $\mu_{L_{ni}}$ ) and fuzzy repetition number ( $\tilde{r}_{L_{ni}}$ ) (Figure 3).

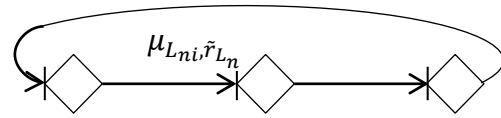

Figure 3 Fuzzy loop

Assumption:

In this method, we consider following assumption for simplicity and applicability, but this method easily can be generalized:

- 1- Duration time of activities is represented by triangular fuzzy numbers.
- 2- Repetitions number of loops is represented by triangular fuzzy numbers.
- 3- Membership degree of activities and loops is a number between 0 and 1.
- 4- Occurrence possibility of loops for different repetitions is equal.
- 5- We used following fuzzy relations in our calculation (Gavareshki, 2004):

$\tilde{N} = (a_2, b_2, c_2), \tilde{M} = (a_1, b_1, c_1)$  Triangular fuzzy numbers

$$\tilde{M} \oplus \tilde{N} = (a_1 + a_2, b_1 + b_2, c_1 + c_2) \tag{1}$$

$$r \odot \tilde{M} = (r.a, r.b, r.c) \tag{2}$$

$$\text{Generalized mean value}(\tilde{M}) = \frac{a+b+c}{3} \tag{3}$$

$$\overline{max}(M, N) = [v(a_1, a_2), v(b_1, b_2), v(c_1, c_2)] \tag{4}$$

$$\overline{min}(M, N) = [\wedge(a_1, a_2), \wedge(b_1, b_2), \wedge(c_1, c_2)] \tag{5}$$

$$A_\alpha = [a_L^{(\alpha)}, a_U^{(\alpha)}] = [(b - a)\alpha + a, (b - c)\alpha + c] \quad \alpha \in [0,1] \tag{6}$$

Note:  $Y_i$ :  $i$ th node,  $x_{ij}$ : activity  $i-j$ ,  $\mu_{ij}$ : membership degree of activity  $i-j$ ,  $\tilde{t}_{ij}$ : fuzzy duration time of activity  $i-j$ ,  $L_{ni}$ : loop  $n$  to  $i$ ,  $\mu_{L_{ni}}$ : membership degree of loop,  $\tilde{r}_{L_{ni}}$ : Fuzzy repetition number,  $f_{i-j}$ : fuzzy ending time of activity  $i-j$ ,  $\tilde{\mu}_{f_{i-j}}$ : membership degree of ending time,  $S\tilde{T}_i$ : Initial release time of node,  $M\tilde{T}_i$ : average time of node,  $\mu_{M\tilde{T}_i}$ : membership degree of node

**2 Materials and methods**

GERT network computations like fuzzy Critical Path method (CPM) (forwarding computation). It performed based on nodes. In this method, nodes were evaluated from start node to end node. Nodes evaluating was doing based on input and output activities

to every node. Initial release time of node ( $S\tilde{T}_i$ ) is time that node with attention to input activities to node was releasing. If output side of node has been loop, namely have existed return possibility, loop time would have been increased to release time of node. Therefore, we were defining for every node another parameter under the title of average time of node ( $M\tilde{T}_i$ ) that was being indicative of average possible times of being released nodes. Steps of algorithm are:

(1) For start node set

$$M\tilde{T}_{Start} = S\tilde{T}_{Start} = (0,0,0) \tag{7}$$

(2) For each node from start to end Compute average time of node ( $M\tilde{T}_i$ )

(3). Computing ending time and membership degree of precedence activities (far input activities to node) (Figure 4):

$$f\tilde{t}_{i-n} = M\tilde{T}_i \oplus \tilde{t}_{i-n} \tag{8}$$

$$\mu_{f\tilde{t}_{i-n}} = \min(\mu_{i-n}, \mu_{M\tilde{T}_i}) \tag{9}$$

(4). Computing initial release time of node( $S\tilde{T}_i$ )

Initial release time of node is calculated based on kind of input side. Since input side are EXCLUSIVE-OR nodes, then:

Normalization of membership degree

$$\mu'_{f\tilde{t}_{i-n}} = \frac{\mu_{f\tilde{t}_{i-n}}}{\sum_{i \in p_n} \mu_{f\tilde{t}_{i-n}}} \tag{10}$$

$$S\tilde{T}_n = \sum_{i \in p_n} \mu'_{f\tilde{t}_{i-n}} \odot f\tilde{t}_{i-n} \tag{11}$$

$$\mu_{M\tilde{T}_n} = \max\{\mu_{f\tilde{t}_{i-n}}\} \tag{12}$$

(5). Computing average time of node ( $M\tilde{T}_i$ )

$$M\tilde{T}_n = \left( \sum_{L \in L_n} \mu_L \odot (S\tilde{T}_n \oplus m\tilde{t}_L) \right) \oplus \left( \left( 1 - \sum_{L \in L_n} \mu_L \right) \odot S\tilde{T}_n \right) \tag{13}$$

(6). Computing project completion time

With evaluating network nodes from first node to end node, project network is scheduled and project completion time is obtained that is equal with average time of end node of project network.

$$T_{project} = M\tilde{T}_{End} \tag{14}$$

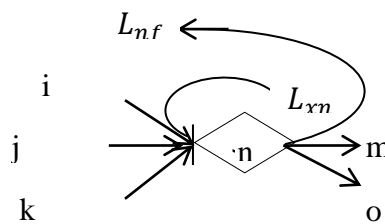

Figure 4 EXCLUSIVE-OR node

Since our input parameters are triangular fuzzy numbers, project completion time and also nodes will be triangular fuzzy number. Now with using of  $\alpha$ -cuts operation and geometrical center of triangular fuzzy number (defuzzification) can analyze result of scheduling. If project completion time have been triangular fuzzy number (a,b,c),  $\alpha$  can be considered as risk level and project manager can compute and analyze time arithmetic of project completion at different risk levels (Wang, 2002). Also we can get project completion time average with computing of geometrical center of triangular fuzzy number (deiiuzification) that is a certain number.

### 3 Results and discussion

In this project, after defining activities, we estimate fuzzy triangular number for each activity as a time. Then we solved the network with fuzzy GERT method.

For scheduling of this project with method of fuzzy GERT, We were doing process below serialization:

- 1) Qualitative description and drawing of GERT network and appointment necessary parameters of network. Project GERT network was getting with understanding of information from project manager that have been showing in Figure 5 and Table 2.
- 2) Solving project fuzzy GERT network that is evaluating nodes and loops (part of computations have been shown in Table 3 and Table 4).
- 3) Computing of project completion time: With evaluating end node also project completion time is getting (Figure 6).
- 4)  $\alpha$  – cut using for Risk levels:

$$A_{0.5} = [(126.52 - 80.81) \times 0.5 + 80.81, (126.52 - 174.22) \times 0.5 + 174.22] = [103.66, 150.37]$$

Where: 103.66 d and 150.37 d are the lower and upper bounds of the closed interval. If we use more  $\alpha$ , we can reach to more accurate interval to estimate our time.

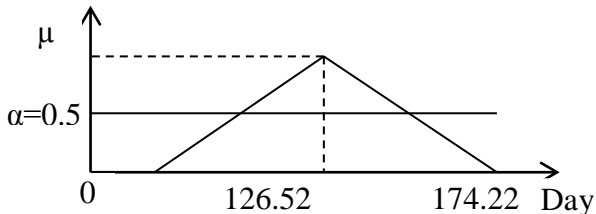

Figure 6 Fuzzy completion time of project

### 4 Conclusions

Fuzzy GERT network with regarding to GERT capabilities (using of logical nodes and branches and

loops) in modeling of research projects and fuzzy ability for uncertainty of project parameters (time, activity definition and sequence) are suitable especially for agricultural mechanization projects scheduling. Fuzzy GERT network is the same probability GERT network that fuzzy parameters have replaced probability parameters and were composed from three parts: logical nodes, fuzzy branches and loops. For first time in this method, a GERT network computation is performed based nodes and resembling of fuzzy CPM method (forwarding computation). In this method, nodes were evaluated from start node to end node. Nodes evaluating was doing based on input and output activities to every node. Process outputs are scheduled network and project fuzzy completion time. These outputs are fuzzy numbers and can be analyzed by  $\alpha$ -cuts.

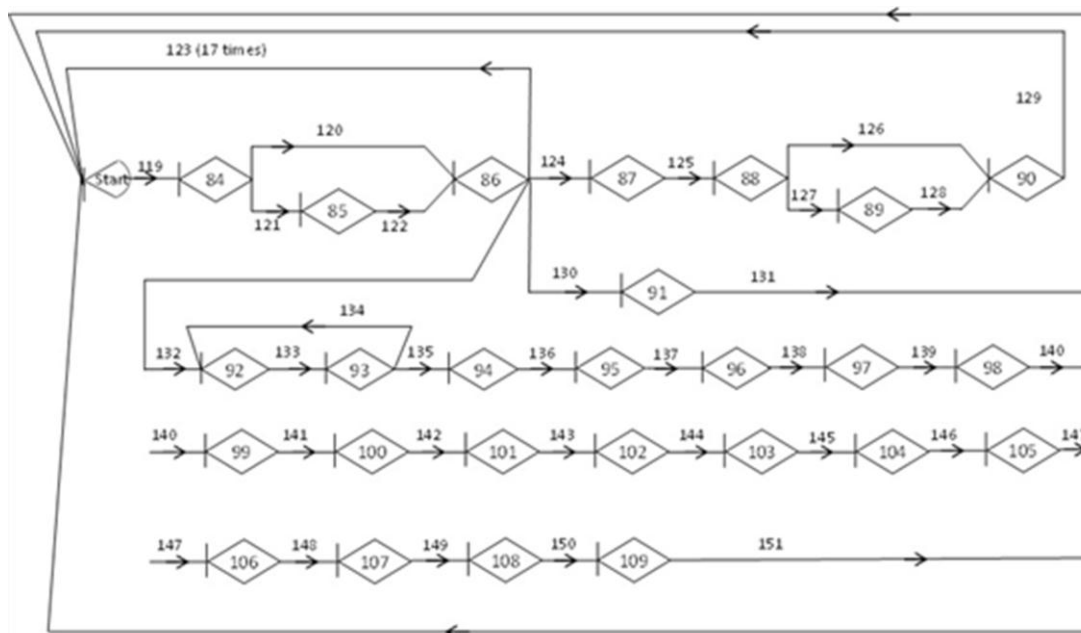

Figure 5 Operations of sugarcane production GERT network

**Table 2 parameters of sugarcane production fuzzy GERT network**

Activity code	Activity description	$\tilde{t}_{ij}$	$\tilde{r}_{ij}$	$\mu_{ij}$
119	Sampling and determination of crop water requirement	(2,2,2)	1	1
120	Decide to non- irrigation	(0,0,0)	1	0.1
121	Decide to irrigation	(0,0,0)	1	0.9
122	Irrigation	(3.5,4,6)	1	1
123	Irrigation (The number of repeat 17 times)	(3.5,4,6)	17	1
124	Biological pest control- parasitoid wasps (second stage)	(1,1,1)	1	1
125	Sampling and determination of crop fertilizer requirement	(2,2,2)	1	1
126	Decide to non- top dressing	(0,0,0)	1	0.1
127	Decide to top-dressing	(0,0,0)	1	0.9
128	Irrigation and top-dressing	(3.5,4,6)	1	1
129	Irrigation	(3.5,4,6)	1	1
130	Biological pest control- parasitoid wasps (third stage)	(1,1,1)	1	0.25
131	Irrigation	(3.5,4,6)	1	1
132	Biological pest control- parasitoid wasps (fourth stage)	(1,1,1)	1	0.25
133	Sugarcane sap test determine the time of harvesting	(1,1,1)	1	1
134	Diagnosis of product prematurity	(0,0,0)	1	0.75
135	Diagnosis of product ripe	(0,0,0)	1	0.5
136	Cut off irrigation and collecting pipes	(1,1,1)	1	1
137	Leveling of marginal lands and filling the beginning of furrows	(1,1,1)	1	1
138	The spunk supply and fire field	(1,1,1)	1	1
139	Harvester, tractor and transporter supply	(1,2,2)	1	1
140	Oil and fuel for harvesting	(1,1,1)	1	1
141	Harvesting and carrying cane to the factory	(6,8,10)	1	1
142	Tractor, trailer and grap loader supply	(1,2,2)	1	1
143	Liliko	(1,2,3)	1	1
144	Oil and fuel for ratooning	(1,1,1)	1	1
145	Subsoiling	(4,5,6)	1	1
146	Reshaper supply	(1,1,1)	1	1
147	Ratoon and reshape	(3,4,5)	1	1
148	Ratoon fertilizing	(3,4,5)	1	1
149	Ratoon spray	(1.5,2,3)	1	1
150	Piping for irrigation	(1,1,1)	1	1
151	Primary irrigation	(3.5,4,6)	1	1

**Table 3 Loop evaluation of sugarcane production fuzzy GERT network**

Loop code $L_{n-h}$	Loop activities $X_{L_{ni}}$	Internal loops $L_{L_{ni}}$	Value time of activity $\tilde{t}_{L_{ni}}$	Total value without internal loops		Total value with internal loops		Average time of loop	
				$\tilde{t}_{L_{ni}}$	$\mu_{L_{ni}}$	$\tilde{t}_{L_{ni}}$	$\tilde{\mu}_{L_{ni}}$	$m\tilde{t}_{L_{ni}}$	$\mu_{m\tilde{t}_{L_{ni}}}$
1	119,120,121,122,123	-	(5.5,6,8)	(58,74,140)	1	-	-	(58,74,140)	1
2	119,120,121,122,124,125,126,127,128,129	1	(15.5,17,23)	(15.5,17,23)	0.75	(21,23,31)	0.75	(18.25,20,27)	0.75
3	119,120,121,122,130,131	1	(10,11,15)	(10,11,15)	0.5	(15.5,17,23)	0.5	(12.75,14,19)	0.5
4	119,120,121,122,132,133,135,136,137,138,139,140,141,142,143,144,145,146,147,148,149,150,151	1.5	(38.5,48,59)	(38.5,48,59)	1	(45,55,68)	0.75	(41.5,60,63)	1
5	133,134	-	(1,1,1)	(1,1,1)	0.75	-	-	(1,1,1)	0.75

**Table 4 Node evaluation of sugarcane production fuzzy GERT network**

Event code	Activities entering to node	Ending of input activity		Initial releasing time of node $S\tilde{T}_i$	Output loop of node		Average releasing time of node	
		$f_{\tilde{t}_{i-j}}$	$\tilde{\mu}_{f_{\tilde{t}_{i-j}}}$		Loop code $L_{n-h}$	$\mu_{m\tilde{t}_{ni}}$	$M\tilde{T}_i$	$\mu_{M\tilde{T}_i}$
S	-	-	-	(0,0,0)	-	-	(0,0,0)	1
84	119	(2,2,2)	1	(2,2,2)	-	-	(2,2,2)	1
85	121	(2,2,2)	0.9	(2,2,2)	-	-	(2,2,2)	0.9
86	120 122	(2,2,2) (5.5,6,8)	0.1 1	(5.13,5.58,7.38)	1	1	(63.13,79.58,147.38)	1
87	124	(64.13,80.58,148.38)	1	(64.13,80.58,148.38)	-	-	(64.13,80.58,148.38)	1
88	125	(66.13,82.58,150.38)	1	(66.13,82.58,150.38)	-	-	(66.13,82.58,150.38)	1
89	127	(66.13,82.58,150.38)	0.9	(66.13,82.58,150.38)	-	-	(66.13,82.58,150.38)	0.9
90	126 128	(66.13,82.58,150.38) (69.63,86.58,156.38)	0.1 1	(68.61,85.35,154.27)	2	0.75	(82.29,100.35,174.52)	1
91	130	(64.13,80.58,148.38)	0.25	(64.13,80.58,148.38)	3	0.5	(70.50,87.58,157.88)	0.25
92	132	(64.13,80.58,148.38)	0.25	(64.13,80.58,148.38)	-	-	(64.13,80.58,148.38)	0.25
93	133	(65.13,81.58,149.38)	1	(65.13,81.58,149.38)	5	0.75	(65.88,82.32,150.12)	1
94	135	(65.88,82.33,150.12)	0.5	(65.88,82.33,150.12)	-	-	(65.88,82.33,150.12)	0.5
95	136	(66.88,83.33,151.12)	1	(66.88,83.33,151.12)	-	-	(66.88,83.33,151.12)	1
96	137	(67.88,84.33,152.12)	1	(67.88,84.33,152.12)	-	-	(67.88,84.33,152.12)	1
97	138	(68.88,85.33,153.12)	1	(68.88,85.33,153.12)	-	-	(68.88,85.33,153.12)	1
98	139	(69.88,87.33,155.12)	1	(69.88,87.33,155.12)	-	-	(69.88,87.33,155.12)	1
99	140	(70.88,88.33,156.12)	1	(70.88,88.33,156.12)	-	-	(70.88,88.33,156.12)	1
100	141	(76.88,96.33,166.12)	1	(76.88,96.33,166.12)	-	-	(76.88,96.33,166.12)	1
101	142	(77.88,98.33,168.12)	1	(77.88,98.33,168.12)	-	-	(77.88,98.33,168.12)	1
102	143	(78.88,100.33,171.12)	1	(78.88,100.33,171.12)	-	-	(78.88,100.33,171.12)	1
103	144	(79.88,101.33,172.12)	1	(79.88,101.33,172.12)	-	-	(79.88,101.33,172.12)	1
104	145	(83.88,106.33,178.12)	1	(83.88,106.33,178.12)	-	-	(83.88,106.33,178.12)	1
105	146	(84.88,107.33,179.12)	1	(84.88,107.33,179.12)	-	-	(84.88,107.33,179.12)	1
106	147	(87.88,111.33,184.12)	1	(87.88,111.33,184.12)	-	-	(87.88,111.33,184.12)	1
107	148	(90.88,115.33,189.12)	1	(90.88,115.33,189.12)	-	-	(90.88,115.33,189.12)	1
108	149	(92.38,117.33,192.12)	1	(92.38,117.33,192.12)	-	-	(92.38,117.33,192.12)	1
109	150	(93.38,118.33,193.12)	1	(93.38,118.33,193.12)	-	-	(93.38,118.33,193.12)	1
(E) 83	123 129 131 151	(66.63,83.58,153.38) (85.79,104.35,180.52) (74.91,58,163.88) 96.88,122.33,199.12)	1 1 1 1	(80.81,126.52,174.22)	-	-	(80.81,126.52,174.22)	1

**References**

Abdi, R., H. R. Ghasemzadeh, S. Abdollahpour, M. Sabzeparvar, and A. DabbagMohamadiNasab. 2010. Modeling and analysis of mechanization projects of wheat production by GERT networks. Elsevier. *Agricultural Sciences in China*, 9(7): 1078-1083.

Abdi, R., H. R. Ghasemzadeh, S. Abdollahpur, M. Sabzehparvar, and A. D. MohammadiNasab. 2009. Modeling and resource allocation of agricultural mechanization projects with GERT networks. *Journal of Food, Agriculture and Environment*, 7(3&4): 438-441.

Ahcom, J. 2004. A model for Benchmarking Contractors Project Management Elements in Saudi Arabia. Ph.D. thesis King Fahd University of Petroleum and Minerals.

Cheng, C. H. 1996. Fuzzy repairable reliability based on fuzzy GERT. *Microelectronic Reliability*, 36(10): 1557–1563.

Cheng, C. H. 1994. Fuzzy consecutive K-out-of-NF system reliability. *Microelectronic Reliability*, 34(12): 1909-1922.

Fahimifard, S. M., and A. A. Kehkha. 2009. Application of project scheduling in agriculture (case study: grape garden stabilization). *American-Eurasian Journal of Agricultural & Environmental Science*, 5(3): 313-321.

Gauri, S. 1988. GERT analysis of sampling plan for system reliability. Department of Mathematics and Statistics, Ravishankar University, Raipur (M.P.), India. *Microelectronics Reliability*, 18(1):23-25.

Gauri, S., and S. Vandana. 1995. GERT analysis of a two-unit cold standby system with repair. Shukla University, Raipur (M.P.), India. *Microelectronics Reliability*, 35(5):837-840.

Gavareshki, M. H. K. 2004. New fuzzy GERT method for research projects scheduling. *IEEE Transactions*, 2(1): 820-824.

- Itakura, H., and Y. Nishikawa. 1984. Fuzzy network technique for technological forecasting. *Fuzzy Sets and Systems*, 14(1): 99–113.
- Kahalzadeh, A. 2000. *Project Management*. Center of University Press.
- Kenzo, K., and N. Nobuyuki. 2002. Efficient Monte Carlo simulation method of GERT-type network for project management. *Computer and Industrial Engineering*, 42(1): 521-531.
- Matsumoto, T., K. Tokimatsu, T. Kosugi, and H. Yoshida. 2007. *Evaluation for Development of Superconducting Technologies in Power Sectors using GERT*. Japan.
- Monjezi, N., M. J. Sheikhdavoodi, and H. Basirzadeh. 2012a. Application of Project Scheduling in Agriculture (Case Study: Mechanized Greenhouses Construction Project). *Research Journal of Applied Sciences, Engineering and Technology*, 4(3): 241-244.
- Monjezi, N., M. J. Sheikhdavoodi, H. Basirzadeh, and H. Zakidizaji. 2012b. Analysis and Evaluation of Mechanized Greenhouse Construction Project using CPM Methods. *Research Journal of Applied Sciences, Engineering and Technology*, 4(18): 3267-3273.
- Takanobu, K., H. Ayami, and M. Tsuyoshi. 2004. Time to realization: evaluation of CO2 capture technology R&Ds by GERT (Graphical Evaluation and Review Technique) analyses. *Energy*, 29(1): 1297-1308.
- Wang, I. 2002. A fuzzy project scheduling approach to minimize schedule risk far product development. *Fuzzy Sets and Systems*, 127(1): 99-116.