

Analysis of straw bruising and sieving system on performance of modified wheat straw combine for better straw quality

Dhimate A. S.^{1*}, J. S. Mahal², Manjeet Singh¹, A. K. Dixit¹, G. S. Manes¹,
R. Khurana¹

(1. Department of Farm Machinery and Power Engineering, Punjab Agricultural University, Ludhiana, Punjab, India;

2. Directorate of Research, Punjab Agricultural University, Ludhiana, Punjab, India)

Abstract: Wheat straw is a major feed source for ruminants. To retrieve the wheat straw and stubbles left after wheat harvesting operation with grain combines, another machine i.e. straw combine is used. But it was observed that the quality straw collected by straw combines contains dirt particles which increases total ash content of straw and that are harmful for animal health. To reduce energy requirement and to reduce total ash content, straw combine was developed with sieving system. Modified straw combine consisted of a 1.53×0.82 m screen with 0.208 mm opening sieving system, which was fixed below the bruising cylinder. Field evaluation of the modified straw combine carried out at two level of concave bar spacing (10 and 14 mm), three feed rate (1400, 1650 and 1900 kg/h) and three cylinder speed (28.45, 32.25 and 36.04 m/s). It was observed that at 14 mm concave bar spacing, 28.45 m/s cylinder speed, minimum net specific energy requirement was found to be 0.42 kWh/q when the feed rate was 1900 kg/h. During straw bruising, average straw length varied from 12.22-20.23 mm and 16.07-25.26 mm at concave bar spacing of 10 and 14 mm, respectively. The maximum split straw percentage was recorded to be 98.43% at the cylinder speed of 36.04 m/s and feed rate of 1900 kg/h at concave bar spacing of 10 mm. The total ash content in the straw was found to be 9.61%, at the concave bar spacing of 14 mm and 1400 kg/h feed rate.

Keywords: Total ash content, straw combine, straw quality

Citation: Dhimate, A. S., J. S. Mahal, M. Singh, A. K. Dixit, G. S. Manes, and R. Khurana. 2014. Analysis of straw bruising and sieving system on performance of modified wheat straw combine for better straw quality. *Agric Eng Int: CIGR Journal*, 16(4): 89-96.

1 Introduction

Wheat is one of the premier and widely cultivated cereal crop of the world. In India, it is the most important source of staple food next to rice and its straw is a major feed source for ruminants. Harvesting of wheat crop is done manually as well as mechanically. Manual harvesting is laborious and time consuming. Combine harvesters as mechanical harvesting have gained popularity over the years due to shortage of labour during harvesting, uncertain weather conditions and less

turnaround time between harvesting and planting of next crop. But combine harvesters leave the wheat straw in field as such. It reduces the availability of straw to livestock, which is already in short supply by more than 40% (Gupta et al., 2004).

Nowadays, straw combine or straw reapers are used by farmers of Punjab to collect the wheat straw after harvesting the wheat with combine harvesters. Basically it is a locally developed machine which cuts, collects and bruises the wheat straw and stubbles left in the field after the operation of grain combine. But it was observed that the straw harvested by straw combine contains soil dirt which exceeds the limit of total ash content and which is harmful for the animal health. Presence of dirt in straw is due to settling of dirt on straw lying in the field, hitting

Received date: 2014-04-09 Accepted date: 2014-11-25

*Corresponding author: Dhimate Ashish Satish, Department of Farm Machinery and Power Engineering, Punjab Agricultural University, Ludhiana. Punjab-141004 (India). Email: ashishdhimate@yahoo.in

of cutter bar of the straw combine on the ground due to undulation, bunds and mice burrows in the fields, poor separation of dirt from the straw during collection in the trailer enclosed by wire mesh during straw combine operation. If cutter bar height is adjusted, conversely reduces the quantity of bruised straw. On an average 13.72% of total ash content was observed and it is beyond the acceptable limit i.e. 7%-8% (Bhardwaj, 2008). Bhardwaj (2008) reported that sieving is appropriate method for dirt separation from bruised straw which is absent in existing straw combine. It also reduces power requirement. In view of these points, the present study was undertaken to develop modified straw with straw bruising and sieving system for the better straw quality and less energy requirement.

2 Materials and methods

The computerized 3D-model of conceptual machine was developed to give better understanding during fabrication of the modified straw combine (Figure 1).

2.1 Constructional details and development of modified straw combine

The tractor drawn modified straw combine (Figure 2) consists of cutting unit, auger, chain type conveyor, bruising cylinder, concave and sieving system. Farmtrac 65 EPI 55 hp tractor was used for evaluating the modified straw combine throughout the experiment. The drive to

the straw combine was given from PTO of tractor. The specifications of the machine are given in Table 1. The descriptions of different components are given below.

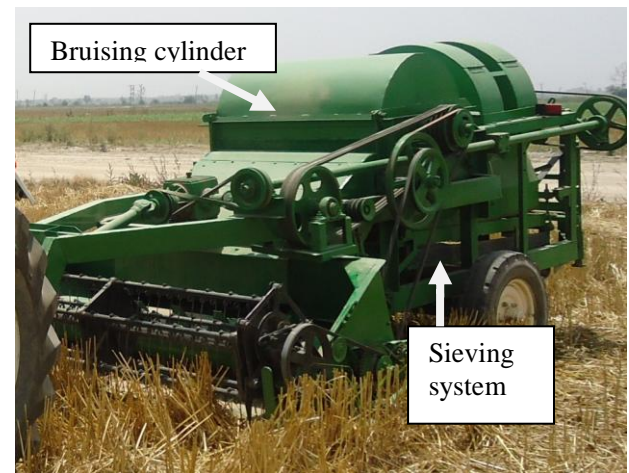

Figure 2 Modified straw combine

Table 1 Specification modified straw combine

Sr. No.	Particulars	Dimension, mm
1.	Overall L × W × H	5050×2320×1820
2.	Width of reel	1910
3.	Width of cutter bar	2160
4.	Width of auger	2160
5.	Bruising cylinder width	1003
6.	Bruising cylinder diameter	725
7.	Straw cleaning sieve	Reciprocating type
	W×L	820×1530

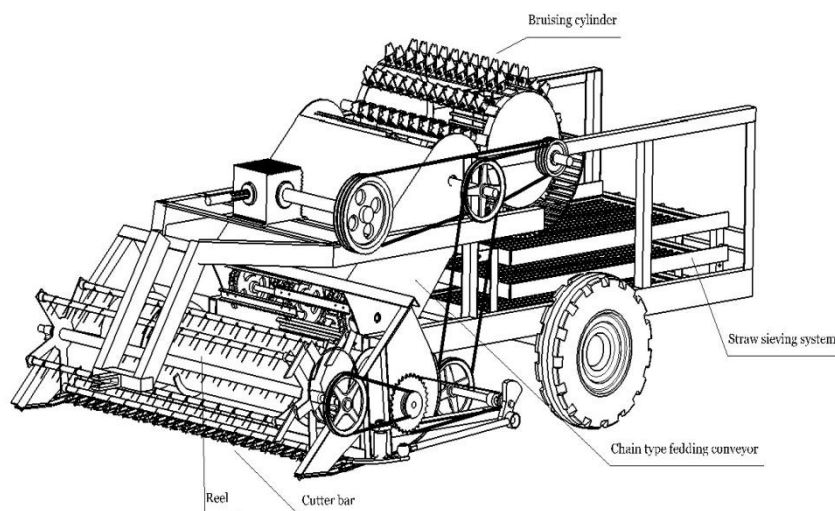

Figure 1 Drafting of 3D model of conceptual modified straw combine

2.1.1 Cutting unit

The cutter bar assembly consists of a cutter bar, which has 28 knives of triangular shape with same number of guards located above the fixed bar. The cutter bar was 2210 mm in length.

2.1.2 Crop reel

The reel diameter was 450 mm while the reel width was 2.12 m. The crop reel had five metal bats fixed along the reel. Seventy tines were placed along the reel bats at an angle of 45° to the vertical, which facilitate lifting and feeding of the stalks to the cutter bar. The crop reel was operated at 67 to 75 r/min.

2.1.3 Platform type auger

On a straw combine, the platform conveyor gathers the crop mass from the sides to the centre of the platform and delivered to the chain type feeding conveyor. The platform conveyor consists of left and right augers with open flight and central section with scoops. The auger length was 2.12 m; the diameter and thickness was 355 and 5 mm respectively. The operating speed of auger was about 160 r/min.

2.2 Development of straw conveying and bruising system

Straw bruising system of modified straw combine was equipped with the chain type feeding conveyor, which was not used in the existing straw combine. It consists of serrated tooth type bruising cylinder. The diameter of bruising cylinder was 725 mm. The 13 blades are mounted on one row shaft and like that 12 rows were mounted on the bruising cylinders periphery in staggered manner to create impact and shearing on straw material for bruising. The cylinder drum was mounted at a height one meter from ground on the frame with bearings and is rotated in a perforated trough-like member, called the "Concave". Concave had wrapping angle of 100° with cylinder and concave clearance was about 25 mm at the front end and 18 mm at the rear end.

2.3 Development of rectangular sieving system

The developed rectangular sieving system is shown in Figure 3 which was not used in regular straw combine. It consists, rectangular screen having dimensions 1.53×0.82 m. The rectangular screens were fixed inside the sieve casing. The sieving system was placed exactly at the bottom of bruising cylinder and it consists of two screen one above the other. This unit is to collect the bruised straw and separate the dirt from the straw through a reciprocating motion provided by the main power source of the straw combine. The bruised straw was received at the upper end of the sieve. Upper sieve size was wire mesh with 4 mm opening size. The lower sieve was also wire mesh with opening size of 0.208 mm, which was suggested for removal of dirt by Bhardwaj (2008).

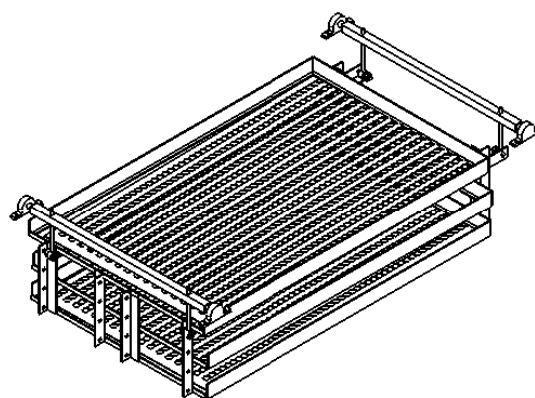

Figure 3 Isometric view of reciprocating sieving system

During the test, sieve oscillations were kept constant at 310 strokes per minute throughout the experiments. Other parameter such as sieve slope was 10° towards backside of machine and stroke length 30 mm are fixed by preliminary trial.

2.4 Power transmission

Farmtrac tractor of 55 hp was used for evaluating the modified straw combine throughout the experiment. The drive to the straw combine was given from PTO of tractor. By using gearbox with ratio 1:1, power was transmitted to the various functional units of straw combine. On output shaft of gearbox, 406 mm pulley was placed. From that pulley power was transmitted to the cylinder by

using V-belt. Again, from cylinder pulley, power was transmitted to the cutting unit. Another 152 mm pulley was mounted on input shaft of gear box which transmit the motion to the sieving unit.

2.5 Evaluation procedure

The newly modified straw combine was tested, at two level of concave bar spacing (10 and 14 mm), three feed rate (1400, 1650 and 1900 kg/h) and three cylinder speed (28.45, 32.25 and 36.04 m/s). During study, feed rate was change by changing forward speed on the basis of created relation (Singh et al., 1998):

$$\text{Feed rate(kg/h)} = 1.75 w V \quad (1)$$

Where,

w is straw density, kg/m²;

1.75m is the effective width of cut of straw combine;

V is the forward speed of combine, m/h.

The present research work was done on wheat crop variety PBW 621. The average height of cut for crop was 211 mm by combine harvester and an average stalk density of the crop was 402 tillers per square meter. Average straw density of wheat straw in field was observed to be 0.481 kg/m². Before starting experiment, average moisture content of straw was measured and it was found to be 7.65% (d.b.), which is suitable for operating a straw combine. Test field was divided into number of plots as per test run length. 50 m test run length was marked with use of measuring tape and two wooden coloured poles. Preliminary trial was taken to decide the engine rpm for getting desired speed. At particular treatment, transmission gear and engine rpm was selected according to required feed rate and cylinder speed. In the field, the machine was driven into uniformly distributed straw and stubble for some distance, until it was fully loaded, before recording for a test run. When the machine passed the first pole (ground mark) test run was started. Fuel meter reading was noted and stopwatch was started. On passing the second pole, fuel meter reading was taken and time was noted. Three replications were taken and straw sample was collected during the trial for further analysis.

The attempt was made to provide nearly similar field condition to the trial.

2.6 Measurement of dependent parameters

The net specific energy requirement was calculated by dividing net power requirement with feed rate. Net power is equal to power required to run machine with load minus power at without load. The power requirement was measured by tractor PTO operated alternator. The straw quality parameter i.e. average straw length and straw split percentage was used. Total ash content was used as dirt content parameter of straw. Sieved straw sample was collected at the end of machine. The average straw length of 50 pieces of each straw sample was measured with a standard scale. The measurement of split straw percentage was done by taking about 100 g of straw sample for each replication. These samples were sorted manually for unsplit straw. On the basis of review of literature, the straw was deemed to be acceptable when (i) splitting of straw was $\geq 92\%$ -95%, and (ii) average size of straw was ≤ 25 mm (size should be range from 15 to 40 mm with acceptable c.v. $\leq 40\%$) (Singh et al., 1998). Dirt content of over sieve straw samples was determined in terms of total ash content as per standard laboratory method (AOAC, 2000). Statistical analysis was done to study the effect of different independent parameters on all dependent variables by using SPSS (Version 20.0) at 5% level of significance.

3 Results and Discussion

3.1 Net specific energy requirement

From the statistical analysis (Table 2), it was revealed that the concave, cylinder speed and feed rate significantly affected net specific energy requirement. Figure 4 shows that the net specific energy requirement increases with increase in cylinder speed. This is because at higher speeds of the blade of cylinder relative to the material causing imparts more force and more number of cut. The obtained results are in line with those reported by Persson (1987). During operation net power

requirement increased with increase in feed rate, because at higher feed rate, the bruising cylinder has to handle more straw mass and decrease in net specific energy requirement was due to the reason that net power requirement increased with decreasing rate i.e. increase in net power requirement was relatively lesser as compared to increase in feed rate. From Figure 4, it is clear that the net specific energy requirements decreased with increase in concave bar spacing. As concave bar spacing increases, lesser resistance was offered for the movement of straw in the cylinder. Wider concave opening allow early and easy passing of bruised straw through the concave which cause less straw crushing. It results in reduction of net specific energy requirement (Pathak, 1970; Sharma, 1994).

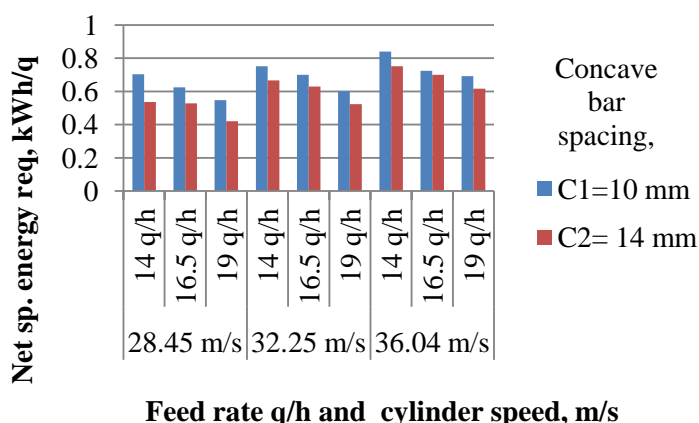

Figure 4 Effect of feed rate and cylinder speed on Net specific energy requirement

Overall average of net specific energy requirement of 0.69 and 0.60 kWh/q was observed at concave bar spacing of 10 and 14 mm respectively. From results it was revealed that the concave bar spacing of 14 mm is better for lesser net specific energy requirement and more feed rate handling. The experimental results showed that 0.54 and 0.42 kWh/q were the minimum values for net specific energy requirement obtained for concave bar spacing of 10 and 14 mm respectively.

3.2 Straw quality

Analysis of variation revealed that the concave, cylinder speed and feed rate significantly affected average length of straw and straw split percentage at 5% level of significance. It can be seen from the Figure 5, the cylinder speed and feed rate, have indirect relation with average length of straw. The reasons already explain in 3.1. The overall range of average length of straw observed at 10 mm concave bar spacing was 12.22 to 20.23 mm whereas in case of 14 mm, it was 25.26 to 16.07 mm. It was also observed that the effect of concave bar spacing was the most significant, followed by cylinder speed and feed rate. In case of straw split percentage, from Figure 6 can be concluded that the split percentage of straw increased with increase in the cylinder speed for all levels of the feed rate. The overall

Table 2 ANOVA for study of effect of various parameters on performance of modified straw combine.

Source	DF	F _{calculated}			
		Net specific	Average	Straw spilt	Total ash
Concave bar spacing (C)	1	180.661*	123.944*	65.249*	5.296*
Cylinder speed (S)	2	189.166*	59.185*	65.182*	0.422
Feed Rate (F)	2	147.934*	59.576*	16.435*	18.545*
C * S	2	9.192*	0.937 ^{NS}	7.235*	0.163 ^{NS}
C * F	2	4.541*	1.102 ^{NS}	2.092 ^{NS}	0.258 ^{NS}
S * F	4	1.796 ^{NS}	2.148 ^{NS}	0.130 ^{NS}	0.875 ^{NS}
C * S * F	4	0.678 ^{NS}	0.744 ^{NS}	0.196 ^{NS}	1.633 ^{NS}
ERROR	36				

Note: *Significant at 5% level; NS = Not significant, DF= Degree of Freedom

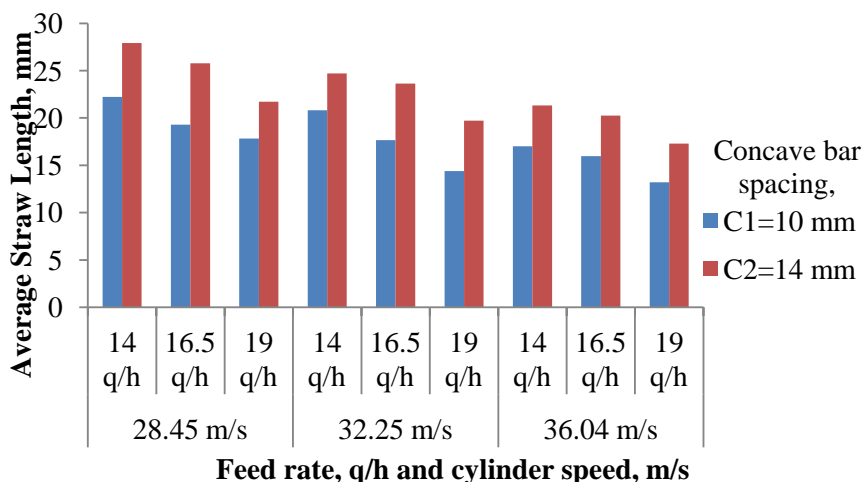

Figure 5 Effect of feed rate and cylinder speed on average straw length

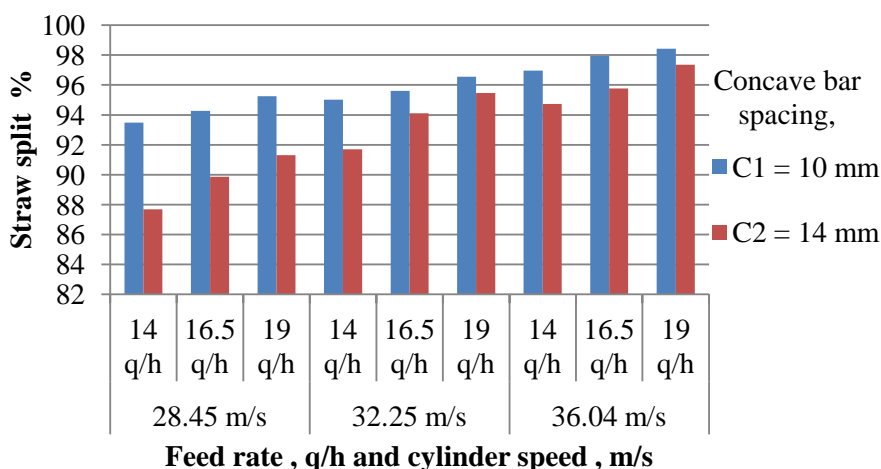

Figure 6 Effect of feed rate and cylinder speed on straw split percentage

range of straw split percentage observed at concave bar spacing of 10 mm was 93.48% to 98.43% whereas in case of 14 mm concave bar spacing, it was 87.69% to 97.35%. This clearly indicates that 14 mm concave bar spacing gives less split straw percentage. The maximum split straw percentage (98.43%) can be seen at the concave bar spacing of 10 mm, cylinder speed of 36.04 m/s and feed rate of 1900 kg/h.

3.3 Total ash content

OVA for percent total ash content of after sieving straw sample at different combination of operational parameter indicates that there is a significant effect of the concave bar spacing and feed rate on the total ash content. Whereas, cylinder speed is not affecting significantly to

the total ash content at 5% level of significance. Similarly, all other interactions were not significant. The obtained average values for percent total ash content after sieving straw samples indicated that at concave bar spacing of 10 mm, total ash content increased with increasing feed rate from 1400 to 1900 kg/h at all cylinder speeds. Also, at concave bar spacing of 14 mm, when feed rate was increased from 1400 to 1900 kg/h, total ash content increased at all cylinder speeds (Figure 7). The increasing behaviour of the total ash content against the feed rate is due to increasing load intensity on the sieve and dirt not separately properly.

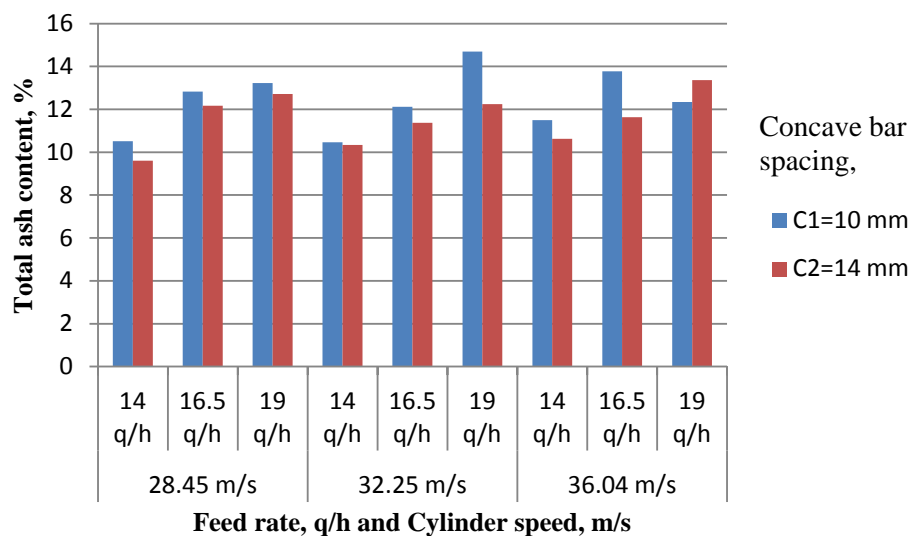

Figure 7 Effect of feed rate and cylinder speeds on total ash content

Also, it was seen that at high cylinder speed, feed rate and less concave bar spacing straw got bruised into fine particles, which increased resemblance to dirt and fine straw particles thereby creating challenges in cleaning operation. This phenomenon was supported by Simonyan et al. (2006) in grain cleaning process. It may be one of the reasons for increasing the total ash content at higher cylinder speed, feed rate and less concave bar spacing. The total ash content in the straw was found to be 9.61%, at the concave bar spacing of 14 mm and 1400 kg/h feed rate. Overall average values of total ash content were found to be 12.38% and 11.56% for concave bar spacing at 10 and 14 mm respectively. The under sieved sample was also analysed for total ash content. It contains about 61%-88% total ash content.

4 Conclusions

- (1). It concluded that net specific energy requirement increased with increase in cylinder peripheral speed and decreased with increase in feed rate.
- (2). Straw quality at concave bar spacing of 14 mm was well within acceptable range for all combination of cylinder speeds of 32.25 and 36.04 m/s except at feed rate of 1400 kg/h and cylinder speed of 28.45 m/s.

- (3). Quality of straw in terms of average length and straw split percentage of modified straw combine almost same as existing one.

- (4). Modified straw combine reduces 4.11% of total ash content as compare to existing straw combine.

- (5). The best performance combination of independent variables at concave bar spacing of 14 mm, feed rate of 1400 kg/h and cylinder peripheral speed of 32.25 m/s for the best quality straw.

References

- AOAC. 2000. Official methods of analysis, Association of official analytical chemists. Washington D.C, USA.
- Bhardwaj, A. S. 2008. *Studies on design parameter for development of a dust separation system for wheat straw combine*. M. Tech. thesis, Punjab Agricultural University, Ludhiana, India.
- Gupta, P K, S. Sahai, N. Singh, C. K. Dixit, D. P. Singh, C. Sharma, M. K. Tiwari, R. K. Gupta, and S. C. Garg. 2004. Residue burning in rice-wheat cropping system: Causes and implications. *Current Science*, **87(12)**:1713-17.
- Pathak, B. S. 1970. Mechanics for straw bruising. *Journal of Agricultural Engineering*, **7(3)**:49-60.
- Persson, S. 1987. Mechanics of cutting plant material, An ASAE Monograph No. 7 St. Joseph 49085, USA.
- Sharma, R. 1994, *Study on selected design and operational parameters on the performance of serrated tooth type wheat*

- threshing system*. M. Tech. thesis, Punjab Agricultural University, Ludhiana, India.
- Simonyan, K. J., Y. D. Yiljep, and O. J. Mudiare. 2006. Modeling the Grain Cleaning Process of a Stationary Sorghum Thresher. *CIGR Journal*, **VIII**:1-17.
- Singh, M., S. S. Ahuja, and V. K. Sharma. 1998. Selected design and operation parameter of serrated tooth type bruising mechanism of a straw combine. *Agricultural Mechanization in Asia Africa and Latin America*, **29(3)**:33-38.