

Development and performance tests of a melon (egusi) seed shelling machine

S.K. Shittu¹✉, V.I.O. Ndrika²

(1. Department of Agricultural Engineering, Bayero University Kano, Nigeria;

2. Department of Agricultural Engineering, Michael Okpara University of Agriculture Umudike, Nigeria)

Abstract: In order to solve the boredom involved in melon shelling operation which is one of the major factors militating against the large scale production, processing and the use of this important oil crop, a power-driven melon seed shelling machine was designed, constructed and tested. The machine consists of a feed hopper, a shelling unit, a delivery chute, a power system and a tool frame. The shelling action was achieved by principle of a rotor that throws melon seeds against the shelling drum by centrifugal force and then the seeds were converged onto a spinning disc with vanes that provide impact force to remove the kernel from the shell. The results of the performance tests carried out showed that the machine shelling efficiency increased with the increase in moisture content and speed. Maximum shelling efficiency percentage of 95% was obtained at the seed moisture content of 26.6% d.b and at 2,190 rpm shelling speed. Percentage seed damage was found to decrease with the increase in seed moisture content. Machine capacity and throughput capacity were 192 kg/h and 796 kg/h respectively. The analysis of variance showed that moisture content and machine shelling speed have significant effect on both shelling efficiency and percentage seed damage at 1% level. Regression models that could be used to express the relationship among the performance indices, moisture content and machine speed were established.

Keywords: melon, sheller, efficiency, seed damage, machine capacity, machine speed, seed moisture content

Citation: S.K. Shittu, V.I.O. Ndrika. 2012. Development and performance tests of a melon (egusi) seed shelling machine. Agric Eng Int: CIGR Journal, 14(1): 157–164.

1 Introduction

Melon (*Citrullus Species*) popularly referred to as “egusi” in Yoruba language is one of the important oil-seed crops widely grown and consumed in tropical Africa. According to Norton (1993) the average protein and oil content of melon seeds are respectively 26.2% and 47.3%, and these values are relatively high compared with corresponding values of some common oil-bearing seeds such as cotton with 20.2% and 21.2% and groundnut with 23.2% and 44.8%, respectively.

Melon is mainly grown for its shelled kernel which could be grounded into a thick paste or sprinkled into a

soup or a stew. It is also a raw material in the production of margarine, salad, “robo cake”, baby food and livestock feeds. Its oil is used in the production of local pomade, soap and its shell is used as poultry litter.

Postharvest processing of melons is usually associated with some impediments such as seed extraction and seed shelling. In Nigeria, substantial research work has been carried out on mechanical melon devices to ease the shelling operation. Fashina (1971) constructed a melon seed shelling machine which works on the principle of bending by feeding seeds through sets of rollers having ridges on their surfaces. Odigboh (1979) designed an impact egusi shelling machine that works on the principle of impact force from spinning disc. Also, Fadamoro (1999) constructed a manually operated melon sheller that works by frictional forces between rotating and stationary discs. Melon shelling by extrusion method

Received date: 2012-01-15 Accepted date: 2012-03-20

✉Corresponding author: Shittu S.K., Department of Agricultural Engineering, Faculty of Engineering, Bayero University Kano, P.M.B. 3011, Kano, Nigeria. E-mail: sarafadeenshittu@yahoo.com

was discovered by Obienwe (2002). Other researchers that have ever tried shelling melon mechanically are: Rotimi (2006), Kafi (1980), Amadu (1981), Ringin (1982), Babale (1988) Mohammed (1989) and Adekunle et al. (2009). Most of those machines were found to have low shelling efficiency but high seed damage. Machine-crop parameters such as seed moisture content, crop variety and inclination or configuration of beater were identified as factors affecting machine shelling efficiency and percentage seed damage (Fashina, 1971; Odigboh, 1979; Amadu, 1981; Mohammed, 2003 and Okokon et al., 2010). The goals of the present study are to develop a melon seed shelling machine using a rotor that throw melon seeds against hard shelling drum by centrifugal force and then converge the seeds onto a spinning disc with vanes that provide impact force to remove the kernel from the shell; to determine the effect of shelling speed and seed moisture content on the machine performance; and to establish regression equations that relate these parameters to the machine shelling efficiency and percentage seed damage.

2 Materials and methods

2.1 Materials

2.1.1 Physical, gravimetric and frictional properties of melon seeds

Some physical, gravimetric and frictional properties of melon seeds that are pertinent to the mechanical processing determined by Davies (2010) were considered by the design and the development of the machine. The properties of the melon variety *Citrullus edulis* that was used are presented in Table 1 and 2.

Table 1 Some physical properties of melon (*Citrullus edulis*) seeds at 6.25% (d.b.)

Properties	Number of Samples	Mean values
Length/mm	100	12.81
Width/mm	100	7.02
Thickness/mm	100	2.22
One thousand unit mass/g	50	94.0
Arithmetic mean diameter/mm	100	7.36
Geometric mean diameter/mm	100	5.84
Sphericity	100	0.47
Surface area/mm ²	50	134.64
Volume/mm ³	100	154.83

Source: Davies (2010).

Table 2 Some gravimetric and frictional properties of Melon (*Citrullus edulis*) seeds at 6.25% (d.b.)

Properties	Mean values
Bulk density/kg · m ⁻³	405
True density/kg · m ⁻³	816.29
Porosity/%	53.7
Angle of repose/degree	36
Coefficient of static friction on:	
Glass	0.35
Plywood	0.51
Galvanized metal	0.43
Concrete	0.56

Source: Davies (2010).

During the development of the machine components, angle of repose, bulk density, porosity and seed dimensions and seed shape influenced the sizing and the shape of feed hopper, rotor and delivery chute. Seed mass, true and bulk densities are parameters that dictate the speed of prime mover that provides adequate seed momentum in the shelling unit.

2.2 Design of machine components

In the design, machine parameters that include the power requirements, machine torque, shaft diameter, pulley and belt sizes and electric motor specifications were determined.

2.2.1 Machine power requirements

According to Daniel (1961),

$$T = Fr \quad (1)$$

where, T = Torque on the shaft, Nm; F = total load on the shaft, N; r = radius of the driven pulley, mm.

By using the relationship between density and volume of mild steel, the total load on the shaft was calculated as 25 N. Taking radius of the driven pulley $R_1 = r$ to be 115 mm, T is calculated as 2.88 Nm.

According Hannah et al. (1984),

$$P = \frac{2\Pi NT}{60} \quad (2)$$

where, P = power required to drive the machine, W; Π = 3.14; N = speed of the shaft, rpm.

Taking the shelling speed N as 2150 rpm (Odigboh, 1979), the power requirement of the machine was calculated as 0.648 kW.

2.2.2 Shaft diameter

Based on the design, the machine uses a vertical shaft

with a majority of its stresses being bending and torsional. It has little or no load to cause buckling. Hence, the diameter of the shaft was calculated thus (Eric, 1976),

$$d^3 = \frac{16}{\pi S_s} \sqrt{(K_b M_b)^2 + (K_t M_t)^2} \quad (3)$$

where, d = diameter of shaft, m; M_b = resultant bending moment, Nm; M_t = torsional moment, Nm; K_b = dimensionless combined and fatigue factor applied to bending moment; K_t = dimensionless combined and fatigue factor applied to torsional moment; S_s = allowable shear stress of the shaft, MN/m².

M_b was calculated as 17.19 Nm by analyzing moments due both horizontal and vertical loading in bending moment diagrams of the shaft. M_t was calculated by Equation (4) (Ryder, 1989):

$$M_t = \frac{P \times 60}{2\pi N} \quad (4)$$

Using $P = 746$ W and $N = 2150$ rpm, M_t was calculated as 3.31 Nm. The values of K_b and K_t were taken as 1.5 and 1.0 respectively for the gradually applied load on the rotating shaft and the allowable shear stress of the shaft S_s as 40 MN/m² based on ASME code. Substituting these values into the equation (3), the minimum diameter of shaft was calculated as 15 mm. The nearest available shaft size 25 mm (1 inch shaft) was used.

2.2.3 Pulley size

According to Aaron (1975),

$$N_1 D_1 = N_2 D_2 \quad (5)$$

where, N_1 = speed of driven pulley, rpm; N_2 = speed of driving pulley, rpm; D_1 = diameter of driven pulley, mm; D_2 = diameter of driving pulley, mm.

Substituting the required speed at the shelling unit $N_1 = 2150$ rpm, the rated speed of the electric motor N_2 was 2800 rpm and D_1 was 230 mm. D_2 was calculated as 177 mm.

2.2.4 Belt selection

Length of belt was calculated by Equation (6) (Khurmi and Gupta, 2004),

$$L = 2c + 1.57(D_2 + D_1) + \frac{(D_2 - D_1)^2}{4c} \quad (6)$$

where, L = length of belt, mm; c = distance between the centre of driving and the driven pulleys. Substituting

values of D_1 , D_2 , and c as 430 mm, the length of belt was calculated as 94 mm. A standard V-belt B55 size having top width 11 mm, bottom width 6 mm and 9 mm thick was used.

2.2.5 Electric motor specifications

A single phase 1hp electric motor with a rated speed of 2800 rpm was chosen for the sheller. It is because it is the range of electric motor available in the market with a specification close to the estimated minimum power requirement of 0.648 kW and by virtue of the seed mass and density the high shelling speed like 2150 rpm recommended by Odigboh (1979) is needed to give the seeds adequate momentum to let the seeds be shelled by impaction.

2.3 Machine description

The main features of the machine are feed hopper, shelling unit, delivery chute, power system and tool frame (Figure 1).

The feed hopper is a square based frustum with 250 mm upper square and 70 mm lower square. It is the structure, through which seeds are fed into the shelling unit. To facilitate the free flow of seeds during the shelling operation, hopper slant sides are at an inclination of seed's repose angle to prevent seeds from piping. Shelling unit consists basically of three parts that include rotor, spinning disc and shelling drum. The rotor is a trapezoidal hollow box of 180 mm long and 55 mm high. Inside the rotor, there are two incline planes that direct seeds to either of its two openings to prevent seed retention. The rotor is mounted on a vertical shaft directly under the lower opening of the hopper. The main function of the rotor is to collect seeds from the hopper, to distribute the seed to the two openings of the rotor and to throw the seeds by centrifugal force against the hard shelling drum to weaken their shells. The rotor's opening size is such that substantial seeds can be ejected from the rotor at once. Spinning disc is a circular plate with a 220 mm-diameter having 13 strips of vanes welded to its surface similar to Odigboh (1979) and Oluwole et al. (2004). The disc is welded to the shaft which is just under the rotor. The seeds flow to the spinning disc by gravity. The spinning disc provides an impact force needed to further break and separate the

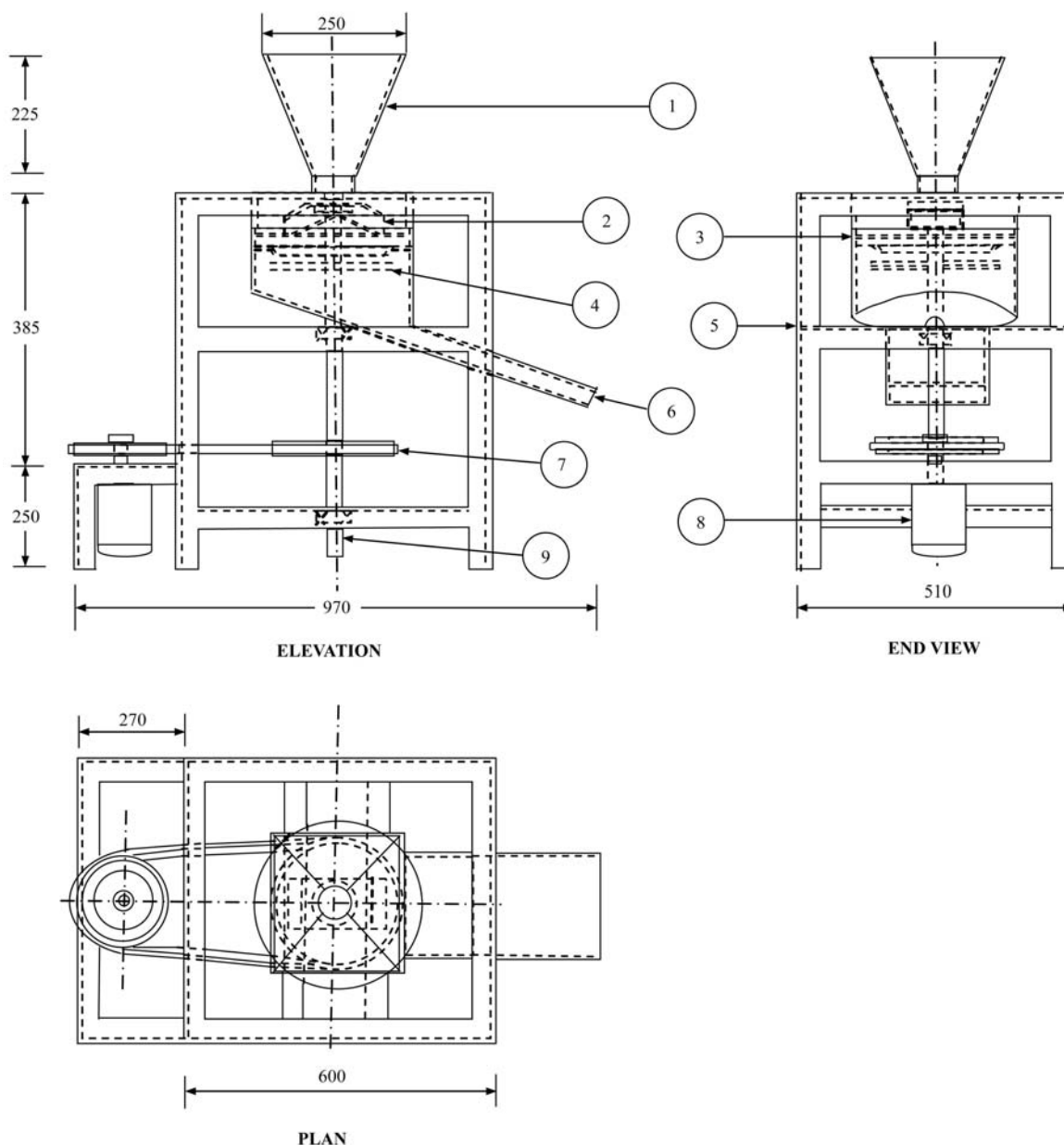

1. Feed hopper 2. Rotor 3. Shelling drum 4. Spinning disc 5. Frame 6. Delivery chute 7. Pulley 8. Electric motor 9. Shaft

Figure 1 Orthographic drawings of the melon seed shelling machine

weakened shells from the cotyledons. Delivery chute is the outlet, through which the mixture of seeds and chaffs are discharged out of the machine. Similar to the hopper, angle of repose of the shelled seed was considered in the inclination of the delivery chute to enable free flow of the shelled seeds and chaffs out of the machine. All the aforementioned components were constructed from gauge 20 sheet metal plate, except the shelling drum that was made from cast iron. The sheller is powered by a single phase 1hp 2900rpm electric motor through a system of belt and pulley. The frame is rectangular of size 580 mm × 520 mm and 700 mm high and made from 1.5

inches mild steel angle iron. It is the main body of the machine that supports other parts.

To operate the appliance, the mains is switched on to start the electric motor that runs the shaft on which the rotor and spinning disc in the shelling unit are arranged. When the machine attains its operational speed, seeds are fed in through the hopper continuously but gradually. The seeds flow through the lower opening of the hopper onto the inclined planes of the rotor and slide towards the rotor's openings. As a result of the centrifugal force developed by the rotor, the seeds are thrown against the stationary shelling drum. The impact force due to seeds

collision with shelling drum weakens the shells of the seeds. The partially shelled seeds flow to the spinning disc that smashes the seeds by impaction to free their cotyledons finally free from the shells. The mixture of shelled seeds and the chaffs flow out of the machine through the delivery chute.

2.3.1 Performance tests

In the performance tests, a completely randomized design with three replications having the moisture content at five levels (m_1, m_2, m_3, m_4 and m_5) and a machine speed at three levels (s_1, s_2 and s_3) was used. Seed initial moisture content was taken as m_1 . Moisture content determination was carried out by using oven drying method as described (Aviara et al., 2007). The seed moisture content was varied by soaking bulk quantity of melon seeds for 12 hours, which is in order to guarantee the seeds fully absorb moisture. The seeds were then sun-dried in a thin layer. Moisture levels m_2 - m_5 were obtained by taking samples from the drying lot every 1 h for four hours. Machine speed was varied by changing the diameter of the driven pulley.

The machine was evaluated based on four indices that include shelling efficiency, percentage seed damage, machine capacity and throughput capacity. These were calculated by respectively using Equations (7), (8), (9) and (10).

$$\eta_e = \frac{W_{su} + W_{sb}}{W_t} \times 100 \tag{7}$$

where, η_e = shelling efficiency, %; W_{su} = number of seed shelled (unbroken); W_{sb} = number of seed shelled but

broken; W_t = total number of seed put into the machine.

$$\eta_b = \frac{W_{ub} + W_{sb}}{W_t} \times 100 \tag{8}$$

where, η_b = percentage seed damage, %; W_{ub} = number of unshelled seed but broken; W_{sb} = number of seed shelled but broken; W_t = total number of seed put into the machine.

$$C_m = \frac{M_s}{T} \tag{9}$$

where, C_m = machine capacity, kg/h; M_s = mass of seed shelled, kg; T = time taken to complete the operation, h.

$$C_t = \frac{M_f}{T} \tag{10}$$

where, C_t = throughput capacity; M_f = mass of seed fed into the machine, kg; T = time taken to complete the operation, h.

A computer program Microsoft Office Excel version 2007 was used to generate the analysis of variance and the SPSS version 11 was used for the multiple regression analysis.

3 Results and discussion

Table 3 shows mean values of machine performance at various speeds and moisture contents. Noting that total number of seeds fed into the machine at various times is different, it is evident from the table that the number of shelled seeds increased with the increase of seed moisture contents. While numbers of seed damage decrease with the increase of the moisture content of seeds at various levels of machine speeds.

Table 3 Results of the performance tests at various moisture contents and speeds

Moisture content /% d.b	Machine speed								
	2100 rpm			2150 rpm			2190 rpm		
	Total No. of seed	No. of Seed shelled	No. of Seed damaged	Total No. of seed	No. of Seed shelled	No. of Seed damaged	Total No. of seed	No. of Seed shelled	No. of Seed damaged
26.6 (0.62)	270 (0.12)	189 (0.53)	27 (0.33)	260 (0.34)	218 (0.61)	49 (0.39)	290 (0.56)	276 (0.71)	49 (0.63)
15.9 (0.31)	300 (0.09)	204 (0.42)	33 (0.50)	290 (0.22)	241 (0.29)	61 (0.46)	300 (0.63)	279 (0.32)	60 (0.46)
9.1 (0.40)	280 (0.18)	182 (0.28)	36 (0.41)	270 (0.28)	221 (0.32)	62 (0.61)	250 (0.44)	218 (0.52)	58 (0.54)
6.9 (0.22)	250 (0.20)	161 (0.55)	45 (0.12)	303 (0.20)	240 (0.64)	76 (0.52)	300 (0.26)	255 (0.48)	81 (0.55)
4.7 (0.19)	280 (0.14)	174 (0.47)	59 (0.48)	251 (0.19)	196 (0.70)	68 (0.39)	270 (0.38)	214 (0.37)	89 (0.51)

Note: Values in parentheses are standard deviations.

The results of analysis of variance (ANOVA) carried out on the performance test results showed that seed

moisture content and machine shelling speed have significant effect on both shelling efficiency and seed

damage percentages at 1% level.

The results of analysis of variance (ANOVA) carried out on the performance test results showed that seed moisture content and machine shelling speed have significant effect on both shelling efficiency and seed damage percentages at 1% level.

Table 4 F-ratios for the results of the performance tests

Sources Of Variation	F-Ratios	
	Shelling Efficiency	Seed damage
Moisture content (<i>M</i>)	10.19*	23.77*
Speed (<i>S</i>)	133.69*	48.17*

Note: *-Significant at 1% level.

Using Equations (7) and (8) the shelling efficiency and seed damaged percentages were calculated and illustrated in figures (2) and (3) respectively.

Figure 2 shows that shelling efficiency of the machine increased with the increase in moisture content and speed. Similar findings were reported by Ringin (1982); Babale (1988) and Mohammed (1989). Highest shelling percentage of 95% was obtained at the seed moisture content of 26.6% and 2,190 rpm shelling speed.

Figure 3 indicates that percentage seed damage decreased with the increase in seed moisture content. At moisture contents less than 10%, percentage seed damage was found to increase with the increase in machine speed. At higher moisture level the percentage seed damage decreases, when the speed was increased from 2150 to 2190 rpm. Lowest percentage seed damage of 10% was obtained at the seed moisture content of 26.6% and 2100 rpm shelling speed.

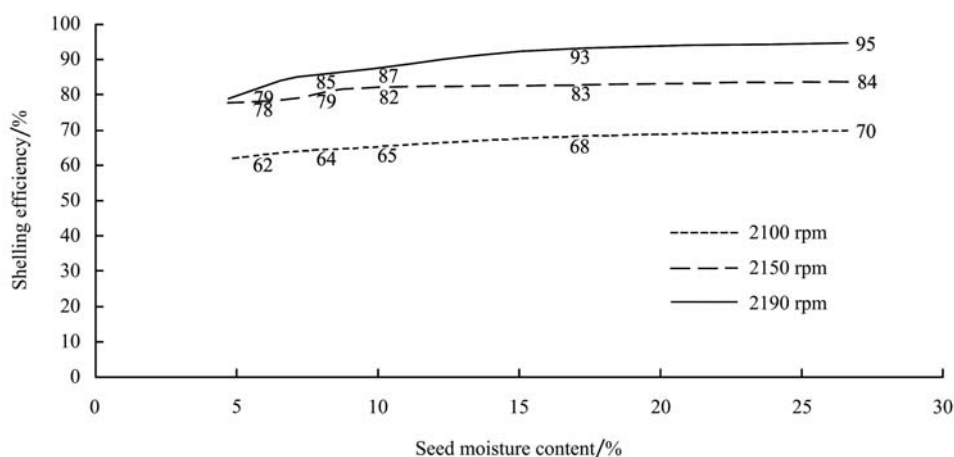

Figure 2 Graph of shelling efficiency vs seed moisture content at various machine speed

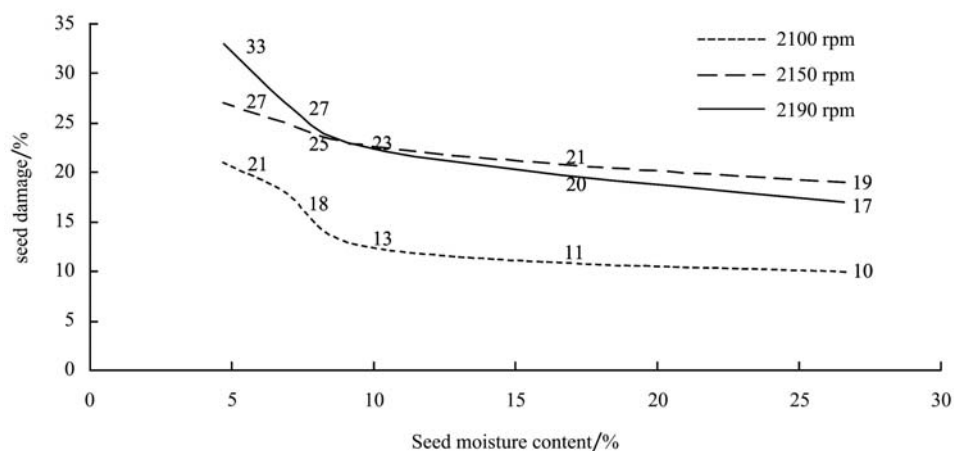

Figure 3 Graph of seed damage vs seed moisture content at various machine speed

Machine capacity (C_m) and throughput capacity (C_t) calculated by using Equations (9) and (10) were

respectively 192 kg/h and 796 kg/h. The C_m and C_t values were taken at 2,190 rpm machine speed and 26.6%

seed moisture content (highest shelling efficiency).

Using multiple regression analysis, the relationship among the shelling efficiency and seed moisture content and machine speed could be expressed by using equation (9) and a similar expression for percentage seed damage and moisture content and machine speed is given in equation (10).

$$\eta_e = 6.12 \times 10^{-3} M^2 + 5.18 \times 10^{-3} M + 1.37 \times 10^{-2} S + 10.78$$

$$R^2 = 0.997 \quad (9)$$

$$\eta_b = -2.27 \times 10^{-3} M^2 - 0.32M + 0.19S - 371.73$$

$$R^2 = 0.82 \quad (10)$$

where, η_e = shelling efficiency; η_b = percentage seed damage; M = Seed moisture content % (d.b); S = Machine speed (r/min); R^2 = coefficient of determination.

Based on the t values of coefficients, seed moisture content was found to make the greatest contribution to the shelling efficiency as compared to other variables. While machine speed is the main predictor of percentage seed damage.

4 Conclusions

Melon seed shelling machine was designed, constructed and tested. Seed moisture content and machine speed significantly affected the performance of the machine. Shelling efficiency of the machine increased with the increase in moisture content and speed within the range of moisture under consideration. Percentage seed damage decreased with the increase in seed moisture content, Equations (9) and (10) can be used to express the relationship among the performance indices, seed moisture content and machine speed. Seed moisture was found to be the main predictor of shelling efficiency while machine speed uniquely predicts percentage seed damage.

Acknowledgement

The authors are grateful to the Institute for Agricultural Research, Ahmadu Bello University Zaria, Nigeria for funding this work.

References

- Aaron, D. 1975. Machine Design. In *Theory and Practice*. London, Collier Macmillan international.
- Adekunle, A.S., I.O Ohijeagbon, and H. D. Olusegun. 2009. Development and Performance Evaluation of Manually and Motorized Operated Melon Shelling Machine using Impact Technique. *Journal of Engineering Science and Technology Review*, 2 (1): 12-17
- Amadu, A.Y. 1981. *Improvement trial of melon seed dehusking machine*. Agric. Engineering Dept., Samaru College of Agriculture, Zaria, Nigeria.
- Aviara, N. A., S. K. Shittu, and M. A. Haque. 2007. Physical properties of gona fruits relevant in bulk handling and mechanical processing. *International Agrophysics*, 21: 7 - 16.
- Babale, M. 1988. *Fabrication of an egusi shelling machine*. Agric. Engineering Dept., Samaru College of Agriculture, Zaria, Nigeria.
- Daniel, S. 1961. 3rd ed. *College physics*, New York, Schaum Series.
- Davies, R.M. 2010. Engineering properties of three varieties of melon seeds as potentials for development of melon processing machines. *Advance Journal of Food Science and Technology*, 2(1): 63-66.
- Eric, O. 1976. 20th ed. *Machinery's Hand Book* New York, Industrial Press .
- Fadamoro, I. 1999. *Design and Construction of a manually operated melon sheller*. Mechanical Engineering Dept., University of Ilorin, Nigeria.
- Fashina, A.B. 1971. *The design and development of a melon sheller*. Project for B.Sc. Agriculture Hons. University of Ife, Nigeria.
- Hannah, J. and R.C. Stephens. 1984. 4th ed. *Mechanics of machine*. London, Edward Arnold.
- Kafi, I.D. 1980. *Development and trial of a dehusking machine for egusi seed*. Agric. Engineering Dept. Samaru College of Agriculture, Zaria, Nigeria.
- Khurmi, R.S. and J.K. Gupta. 2004. *Theory of Machines*. New Delhi: Eurasia Publishing house.
- Mohammed, K.M. 1989. *Fabrication of an egusi shelling machine*. Agric. Engineering Dept. Samaru College of Agriculture, Zaria, Nigeria.
- Norton, G. 1993. *Gona seed analysis*. Applied Biochemistry and Food Science Dept. The University of Nottingham, UK.
- Obienwe, D.S. 2002. *Design, Construction and Testing of an Electrically Powered Melon Sheller*, M. Eng. thesis. Department Mechanical Engineering University of Ilorin, Nigeria.

- Odigboh, E.U. 1979. Impact egusi shelling machine. *Transaction of the ASAE*, 22 (5): 1264-1269.
- Okokon, F.B., E. Ekpenyong, C. Nwaukwa, N. Akpan, and F. I. Abam. 2010. Analysis of the impact forces on melon seeds during shelling. *CIGR Journal*, manuscript No. 1276.
- Olaniyan, A.M. and K. Oje. 2000. Mechanical expression of palm oil. *Proceeding of the Nigeria Institution of Agricultural Engineers*, 22: 87-89.
- Oluwole, F.A., N.A. Aviara, and M.A. Haque. 2004. Development and performance tests of a sheanut cracker. *Journal of food Engineering*, 64 (1): 117-123.
- Ringin, A.N. 1982. *Fabrication of an egusi shelling machine*. Agric. Engineering Dept. Samaru College of Agriculture, Zaria, Nigeria.
- Rotimi, O.O. 2006. *Design and Construction of Melon Shelling Machine*. B. Eng., Project work, Mechanical Engineering Dept. University of Ilorin, Nigeria.
- Ryder, G.H. 1989. 3rd ed. *Strength of materials*. Nigeria, Macmillan/ELBS.