

Design and development of small scale pea depoding machine by using CAD software

Parminder Kamboj^{1*}, Amarjit Singh^{1*}, Mahesh Kumar^{1*}, Salam Din^{2*}

(1. Department of Processing and Food Engineering, Punjab Agricultural University, Ludhiana, India;

2. Department of Computer Science & Electrical Engineering, Punjab Agricultural University, Ludhiana, India)

Abstract: Agriculture mechanization played a significant economic role by increasing agriculture production and reducing cost of cultivation. Agricultural mechanization has improved productivity to great extent, still post-harvest value addition to the raw product in India is very less as compared to other countries, which may be mainly due to lack of technologies. There is a dire need to develop more processing machinery for value addition of agricultural produce with a reduction in time and labour. Pea is an important cool season, leguminous crop of India. Manual removal of peas from pods is a labourious and time consuming job. In view of non-availability of efficient pea depoding machine work on design and fabrication of pea depoding machine was undertaken by Punjab Agricultural University during 2009-2011. Computer aided design of machine was made by using "SolidWorks" software. This design helps to find out the typical dimensions of various components of machine with great accuracy in small time and also gives fine representation of pea depoding machine by using simulation. The machine was fabricated by using the low cost material available in market. Main components of this machine are – frame, sieve, L-shaped blades, conveying blades, hopper, trays, motor and gear box. Depoding of pea grain is based on the principle of friction generated by rubbing action of blades with the pea pods on sieves which helps in opening the pods of peas and cutting action of conveying blades. Initial tests were done on the designed machine and it was observed that 60 r min⁻¹ of blade shaft was best suited for depoding of pea from pods. The average throughput capacity of the machine was 30 kg h⁻¹. This machine will surely help farmers by adding the value to agricultural products.

Keywords: pea depoder, pea sheller, computer aided designing, solid modelling and simulation, shelling machines designing, designing of machines

Citation: Kamboj, P., A. Singh, M. Kumar, and S. Din. 2012. Design and development of small scale Pea Depoding Machine by using CAD software. *Agric Eng Int: CIGR Journal*, 14 (2): 40–48.

1 Introduction

Agricultural mechanization played a significant economic role by increasing agriculture production and reducing cost of cultivation. Mechanization implies the use of agricultural machinery in performing the farm operations speedily and efficiently. Thus it helps in

increasing productivity and overall returns to the farmers (Kamboj, 2009). Although agricultural mechanization has improved productivity to great extent, still post-harvest value addition to the raw product in India is only 7% which is very less as compared to other countries (Bist, 2010).

There is a large scope of vegetable processing as green vegetables are very essential item of daily food. Among vegetables green peas occupy important place. Peas are very popular among people due to high nutrition value and good taste. Fresh peas are rich source of protein, amino acids, carbohydrates, vitamin A and C, calcium, phosphorus and iron also (Hulse, 1994). The commercially grown varieties of peas are - Arkel,

Received date: 2011-12-09 **Accepted date:** 2012-05-25

***Corresponding Authors: Parminder Kamboj**, M. Tech (PFE), Mobile: +919478771932, Email: parminderkamboj2001@gmail.com; **Amarjit Singh**, Sr. Extension Engineer, Mobile: +919888889721, Email: amarjeetpau@rediffmail.com; **Mahesh Kumar**, Associate Professor, Phone: 0161-2401960, Email: maresh@pau.edu; **Salam Din**, Assistant Professor, Phone: 0161-2401960, Email: dinsalam@pau.edu.

Bonneville, Harbhajan, FC-1, Jawahar Peas 83, JP 4, JM 6, Matar Ageta 6, Mithi Phalli, Pantnagar Matar 2, and Pant Uphar (IP 3), (Anonymous, 2010).

Peas are produced on over 84 countries. India accounts to a production of $12-15 \times 10^6$ t of pulses and pea constitutes to around 20% of the share in it. The crop yields are between 5 to 6 t ha⁻¹. Production of peas in India is 29.16×10^5 mt with an area of 348×10^3 ha (Anonymous, 2009a). In India peas are mainly grown in Uttar Pradesh, Himachal Pradesh, Jharkhand, Madhya Pradesh, Punjab, Haryana and Uttaranchal. Punjab stands the fifth in pea production in India and contributes 3.8% of the total production of India (Anonymous, 2009b).

Manual removal of kernels from green peas is time consuming, laborious as one person can depod about 3-3.5 kg of green peas from pods in one hour (Sharma and Singh, 1989). The depoding machine not only helps to reduce the time for depoding of pea pods, but can also be used as a good opportunity for small farmers. By packing the depoded green pea grain, they are able to get more income on investment. Some attempts were made to make a machine for shelling the peas and similar leguminous crops on commercial and large scale as well as on small scale. But various types of functional problems were observed during their operation. The observed efficiency of peas shelling was also not recorded. Hence there is an immense need of making a new model of pea depoding machine which could be easily used on farmer level as per Indian conditions.

Design of machine is not an easy task. Over a period of time, design of different machines was done by using the paper and drafting tools, but now most of the designing work is done by using CAD (Computer Aided Design) tools. A lot of CAD software is available in the market like Auto Cad, PRO-E, Solid Edge, Solid Works etc. Different software has different functionality and used by specific fields for specific purposes. Some CAD software not only generates sketches and 3D models of the machines, but also includes simulation and structural analysis of the model. Solid Edge, Catia and SolidWorks are software which provides all features desired to develop and analyse the machine stresses and forces even before actual making of the physical model.

CAD technology is very helpful for the design engineers as it provides extendibility to design easily.

Some of the researchers have used the CAD software for the design of solid model of their machines such as Singh (2007) developed a wheel hand hoe mounted twin disc fertilizer broadcaster CAD model using computer aided software called PROE and different parameters such as soil thrust are checked later. Kumar (2009) designed and developed a 3D model of Multi-Crop thresher by using the 'Solid Edge'. Singh (2009a) developed a solid model of tractor operated rotary weeder with the help of commercially available 'Solid Edge'. Singh (2009b) designed a solid model of manually operated axial flow vegetable seed extraction machine in 'Solid Edge'. Solid modelling can be used for developing the machines before actual development of machine.

Some others researchers used CAD for specific purpose of optimisation of various parameters such as Lye and Salleh (1997) investigated a two dimensional model of agricultural plough to compute the effect of different shapes of plough blade (C-blade, L-blade & I-blade) and stress distribution by using "Micro Field Finite Element Package" and concluded that L-blade created the highest displacements and stresses over the blade compared to the C-blade and I-blade. Gadus (2000) optimised the frame of the special agricultural machine used to cultivate lands by using the software "pro/MECHANICA" and obtained the reduction in cost of frame by 10.4% by selecting the optimum material as well as optimising the area of frame and keeping the given strength of 120 MPa. Singh (2004) optimised the performance of No-Till Drill in the solid modelling and analysing software "Ideas". The performance was affected by various independent parameters and it was concluded that uprooting of the stubble mainly affected by the like shape of the openers which was optimized by designing the different solid models of openers.

CAD softwares help in future expansion of model by providing facilities to modify the designed work later. As there is wide scope of CAD in agricultural field, therefore an attempt to design the pea depoding machine was made by using CAD software.

So keeping in view of these loopholes, the present study has been undertaken with the following objectives:

- Select the suitable software for designing
- Design of pea depoding machine by using CAD (Computer Aided Design) software

2 Materials and methods

This heading includes the description of method used in designing and development of pea depoding machine. The whole work of designing and fabrication was done under following phases:

- Design considerations
- Selection of CAD software
- Designing and fabrication of prototype of pea depoding using CAD

2.1 Design considerations

Before designing the CAD model, it was essential to consider various facts for designing such as blade and their sizes, frame design etc. Among the extraction methods, the rubbing action would produce seed with minimum damage (Allen and Watt, 1998). Therefore, depoding of pea grain is based on the principle of friction generated by rubbing action of blades with the pea pods on sieves which helps in opening the pods of pea and cutting action of conveying blades (Sharma and Mandhyan, 1988). Some researchers tried to make depoding machines such as Sharma and Mandhyan (1988) developed a manually operated pea peeler and tested it at different surfaces-punched tin sheet, tyre thread, and gunny bag cutting and concluded that maximum kernel recovery was possible by using punched tin sheet with roller speed of 45 r min^{-1} . Kaur (2006) developed pea depoding machine by using the L-shaped blades. Machine was tested at 40 to 50 r min^{-1} and observed shelling efficiency of the machine was 69.5%. Goyal (2007) tested the depoding machine equipped with wooden depoder at 80 to 120 r min^{-1} , and observed the shelling efficiency of 80% with 15% of damaged kernels. On the basis of literature, various parameters which can affect the depoding of peas were selected and analysed in order to make a good design and described as follow:

1) Size of pea grains –Pea grain size is the geometric mean of the three dimensions i.e. length, breath and

thickness. The size was calculated using Equation (1) (Kachru, Gupta and Alam, 1994)

$$\text{Size} = (L \times B \times T)^{1/3} \quad (1)$$

where, L = length, B = Breadth, T = Thickness.

Fresh peas were procured from market and dimensions of peas were measured by using “Vernier caliper”. Overall size of pea grain was 9.38 mm. On the basis of pea grains dimension the clearance between sieve and blades was set as 10 mm.

2) Size of blades - The size of blades (Figure 1) is one important parameter which affects the efficiency of depoding of pea pods. Size of blades is defined as a size which directly comes in contact with the pea pods during the process of depoding. The length of blades is kept constant while the width of blades varies according to the size of different pea pods. So the size of blades varies directly by varying the width of blades.

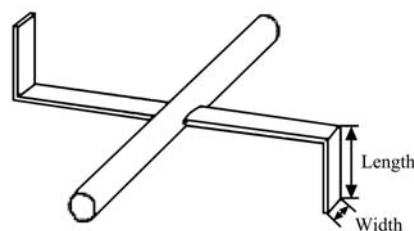

Figure 1 Size of blades

Overall length of pea pods varies from 50 to 60 mm.

3) Slope provided to the sieves - Slope of sieves helps in moving the shells and trash to the waste discharge end. It works on the principle of discharge by gravity. It was observed that a slope of 3° was enough for this purpose.

4) Feed Rate - Feed rate also affects the efficiency of machine. So a proper feed rate was decided. It can be controlled by selecting the proper method of feeding or by designing the hopper having a proper size.

5) Clearance between blades and sieve - It is defined as the distance between the sieve and surface of blades. Clearance has a great effect on depoding efficiency of pods. Lesser clearance leads to more breakage of pea grains and more clearance leads to more unthreshed peas at outlet.

6) Conveying blades - Conveying blades should be such that cutting of peas should be decreased and

maximum depoding of grains should be achieved. So to avoid unthreshed peas at outlet and to provide proper conveying, angles of conveying blades should be proper.

In order to optimize the conveying, the angle of first blade was kept minimum to avoid the accumulation of material near the hopper. Also the angle of last blade was kept minimum so that trash comes out from outlet easily. A proper gap was maintained between blades to avoid the choking of material in them.

2.2 Selection of CAD software

In earlier time, designing was the most critical process in the industry. It involved lot of skilled engineers, machinery and prototypes. Designs were made by persons having good skills of drafting tools. The cost of designing was very high due to creating, optimization, analysis and modification again and again. A part was created and modified almost hundreds of time to get the final design. But these days such kinds of control systems are available which are replacing the operator by computer. A design can be easily made and checked by using computers. From Figure 2, the relation between conventional designing and the computer aided designing can be easily understood.

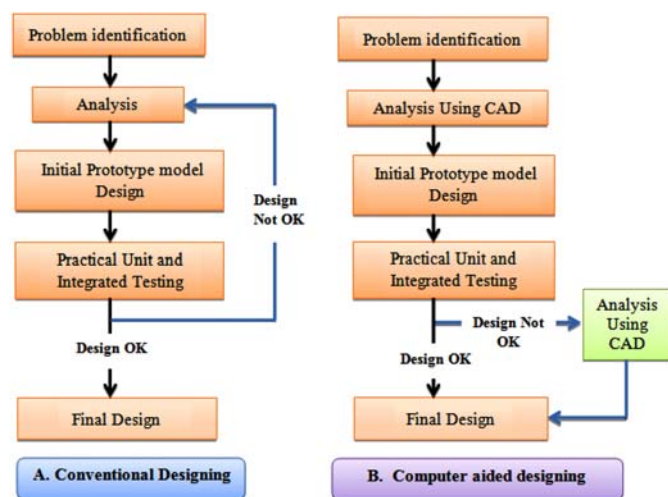

Figure 2 Comparison between conventional and computer aided designing

From Figure 2, it is clear that CAD helps to reduce the time and cost for designing of machine by reducing the repeated analysis and prototype building (Anonymous, 2011).

2.2.1 Computer Aided Design (CAD)

Computer Aided Design (CAD) is assistance of computer in engineering processes such as creation, optimization, analysis and modifications. CAD involves creating computer models defined by geometrical parameters. These can be readily altered by changing relevant parameters. CAD systems enable designers to view objects under a wide variety of representations and to test these objects by simulating real-world conditions.

2.2.2 Basic procedure for selection of CAD software

There is a long list of CAD software available in the market. Following was the procedure followed in order to select the CAD software for designing purpose:

1) Literature had been reviewed so as to get the knowledge of CAD software used for the agricultural purpose. Review involves these software: PRO-E, Solid Edge, Ideas, Micro Finite Element Package, Pro Mechanica etc.

2) The CAD department of PAU is consulted regarding availability and relative guidance for the selection.

3) Information of different CAD software searched from internet and data is collected. A list of newly available CAD software having capabilities of designing, manufacturing and analysis is given below:

- a) PRO-E
- b) CATIA
- c) SolidEdge
- d) Solid Works

4) This list was consulted with the CAD department and SolidWorks software is recommended as best suited for design purpose due to the availability of a lot of enhanced features of designing within the package.

In order to make a good design, a plan was proposed to design the pea depoding machine. SolidWorks software not only provides all features desired to design and develop the machine, but also helps to analyse the stresses and loads on different parts even before the actual making of physical model. Typical dimensions of pea depoding machine such as proper blade size, proper distance etc. and their 3D models can be easily made in small time with the help of this software. In this way,

this software helps to reduce the time wastage by reducing the time for making the paper layout of machine.

2.2.3 SolidWorks (CAD/CAE)

SolidWorks is a 3D mechanical CAD program that runs on Microsoft Windows and is being developed by Dassault Systèmes SolidWorks Corp., a subsidiary of Dassault Systèmes, S. A. (Vélizy, France).

SolidWorks is the world's most popular CAD software. Its user base ranges from individuals to large companies, and covers a very wide cross-section of manufacturing market segments. Commercial sales are made through an indirect channel, which includes dealers and partners throughout the world. Directly competitive products to SolidWorks include Pro/ENGINEER, Solid Edge, and Autodesk Inventor.

Products

- a) SolidWorks Standard
- b) SolidWorks Professionals
SolidWorks Premium
- d) SolidWorks Education Edition

Features

- a) Design Validation Tools
- b) Product Data Management Tools
- c) Design Communication and Collaboration Tools
- d) CAD Productivity Tools

2.3 Designing and fabrication of prototype of pea depodding using CAD

Designing of machine was done by using "SolidWorks" software and fabrication was done by using different materials. Initial trails were taken in order to calculate effectiveness of machine.

The main components of pea depodding machine are frame, shaft, blades, sieve, trays, gear box, motor, feeding hopper, pulley, belts, bearings etc. various components and their drawing are described under following headings

1) Frame - A frame of mild steel of 760 mm × 625 mm × 970 mm (length × width × height) was fabricated with angle iron of size 40 mm × 40 mm × 20 mm (Figure 3).

2) Shaft - A shaft of mild steel was machined into length of 1,000 mm and dia. 25.12 mm. Its ends were fitted with the bearings fitted on frame.

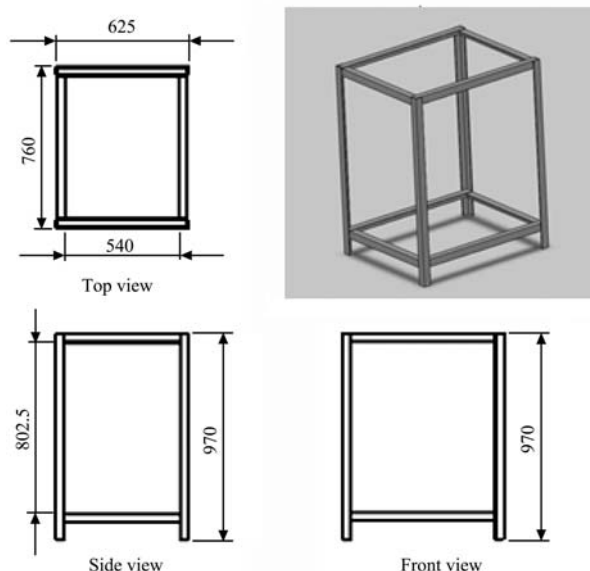

Figure 3 Main frame of machine with drawing

3) L-Shaped blades - L shaped blades were used for designing as these blades provide proper rubbing action. Therefore five L-shaped blades aligned at 45° were used so that rubbing action should be proper and uniform on the whole crop. The blades were designed in such a way that their size as well as clearance can be adjusted to perform different experiments at different clearances. The function of these blades was to open the shells of peas with the help of rubbing action between the blades and the sieve and by impact action of the blades.

4) Conveying blades - These blades were fabricated in the workshop of Department of Processing and Food Engineering, Punjab Agriculture University, Ludhiana. The function of these conveyor blades was to cut the shells of the peas and to move the shells or trash towards the discharging end of waste.

5) Sieve - The sieve was made from a galvanized iron sheet having holes of 13 mm diameter. The sheet was bent into a concave shaped structure which holds the shells or trash over it and allows the pea grains to pass into the collecting tray fixed below it. The sieve was tapered by 3° from the horizontal with wide open side towards the discharge end of trash.

6) Upper cover - The upper cover of machine was fabricated with the help of GI sheet. Main function of upper cover is to cover the upper part of the machine. It was closed from the sides which help to prevent the passage of material from the top during the operation.

7) Hopper - Hopper was fabricated by using the GI sheet. Main function of the hopper was to control the feed rate without choking of machine. A hopper plate was provided with hoper which helped to control the passage of material from the hopper.

8) Collecting trays - Two trays were used and proper slope was provided for collection of clean grains at the outlet. Peas and trash were accumulated on the first tray. Slope was provided to the first tray so that peas could easily move to the second tray. The trash remained over the first tray and clean peas were collected through pea grains outlet from the second tray.

9) Gear box - A gear box was used to change the revolutions per minute. It was fitted with two pulleys i.e. driver and driven pulleys. The reduction ratio was 20:1.

10) Motor - A single phase DC motor was used as a power source having following specifications.

11) Bearing - These were provided at the ends of the shaft for smooth and frictionless running of shaft. The bearings also helped to maintain the clearance between blades and sieve.

12) Vibrating assembly - Vibration assembly (Figure 4) was the combination of various parts such as rotator, links etc. The main function of this assembly was to give some vibrations to grains so that they easily moved towards the outlet and did not stop by the trash on the tray.

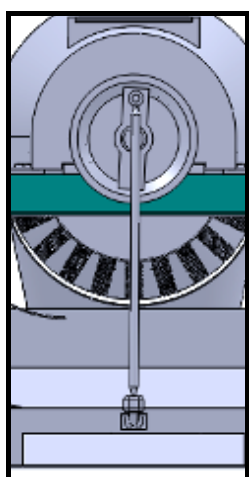

Figure 4 Vibrating assembly attached to pulley and first tray of the machine

All these components were connected with each other using the software and then fabricated in the workshop of department of Processing and Food Engineering.

The final model after combining all parts was shown in the Figure 5.

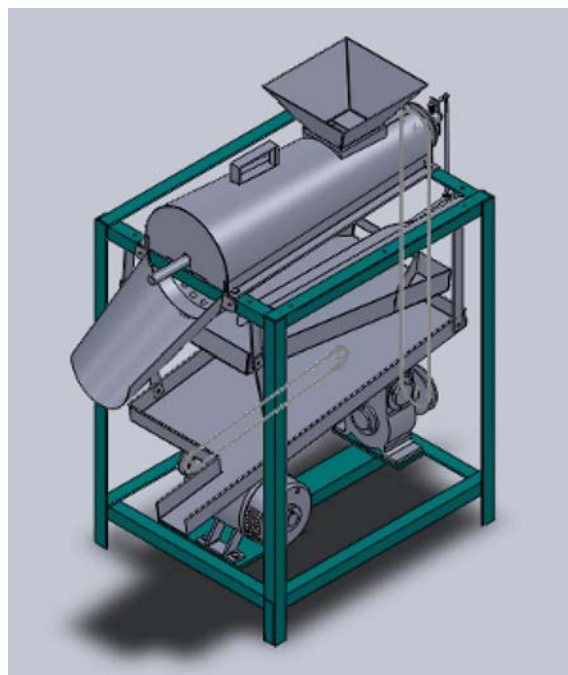

Figure 5 Isometric CAD view of pea depoding machine

3 Results and discussion

This chapter includes the procedure followed during the testing of machine. It also includes the analysis of data and observed results. The whole chapter is summarized under following headings:

- Tests to check the parameters
- Specifications of fabricated pea depoding machine

3.1 Tests to check parameters

After of fabrication of machine, the tests were done in order to maximize the various machine parameters and to reduce the breakage. The whole procedure was summarized as follows:

1) A slope of 3° was provided to the machine sieve for easy conveying by gravity. But during the tests it was observed that the conveying was not proper, so conveying blades were introduced on rod. In order to optimize the conveying, the angles of conveying blades were checked during the design. It was kept into mind that there should be proper retention time of material for depoding with minimum breakage. The angles of various conveying blades were given as 40° , 45° , 55° , 60° , and 45° . The angle of first blade was kept smaller to

avoid accumulation of peas whereas angle of last conveying blades kept smaller so that trash easily move towards the outlet.

2) In order to check the movement of shaft during the operation, the bearings were used.

3) The five L-shaped blades aligned at 45° were used so that rubbing action should be proper and uniform on the whole crop. The blades were designed in such a way that their size as well as clearance could be adjusted to perform different experiments at different clearances.

4) During the tests, it was observed that some of material moved along the circumference of sieve with the blades and remained unthreshed. To avoid this and to obtain maximum threshing, a long flat was introduced to the length of the sieve which not only provided rigidity to sieves but also helped to stop the peas and provided better

contact for the rubbing action. Two round flats were introduced on each side of sieve to provide rigidity.

5) Two guiders were provided (one was on outlet of trash and one was on outlet of pea grain collector) for easy collection.

6) A DC motor with RPM regulator was used to control the RPM for different tests.

7) Feed hopper was designed in such a way that pea pods were fed at a uniform rate. Over feeding should be avoided which could affect the performance of machine.

8) Standard belts and pulleys which were available in market were used for fabrication. These were selected in such a way that there should be no slippage between pulley and belt.

9) Tests of one kg samples were taken at different speeds of blades and summarized in Table 1.

Table 1 Effect of RPM of blade shaft on the depoding of peas

RPM	Time of Depoding	Weight/g		Unthreshed peas %	Observations
		Intact peas	Damaged peas		
40	4:00	310	40	4.0	Damage of grains was high and time of depoding was high.
45	3:30	330	35	5.5	Damage decreased, but time of depoding was high.
50	3:10	390	30	5.0	Observable trash on the tray, damage was still high and time for depoding decreased.
55	2:48	430	20	2.5	Trash on tray increased, damage of grains and unthreshed peas decreased
60	2:20	460	12	2.0	Trash on tray remains same, time decreased, damage of grains decreased, unthreshed peas decreased
65	2:10	455	15	2.2	Trash on tray remains same, time decreased, damage of grains decreased
70	2:00	400	20	6.0	Trash on tray increased, time decreased, damage of grains increases, unthreshed peas increased

From these observations, it is clear that 60 RPM of blade shaft was best suited for depoding of pea from pods.

3.2 Specifications of fabricated pea depoding machine

Pea depoding machine was designed by using the CAD software which helped in designing the typical dimensions easily and fabricated by using the low cost material available in the local market. Various specifications and various parts of this machine are shown in Table 2 and Figure 6, respectively.

Table 2 Specification of pea depoding machine

Item	Parameter	Dimension
Machine parameters	a) Overall length	760 mm
	b) Overall width	625 mm
	c) Overall height	970 mm
Shaft parameter	a) Length of shaft	1000 mm
	b) Dimension of shaft	25.12 mm
L-Shape blades	a) No. of L-Shape blades	10
	b) Spacing between L-shape blades	Approx. 98 mm
	c) Width of L-Shape blades	Varies from 1.25" to 2.5"

Item	Parameter	Dimension
Conveying blades parameters	a) No. of conveying blades	10
	b) Angle of conveying blades	40°, 45°, 55°, 60°, 45°
Sieve parameters	a) Radius of sieve on hopper side	135 mm
	b) Radius of sieve on outlet side	100 mm
	c) Slope on sieve	3°
	d) Length of sieve	750 mm
Motor	a) Type of motor	DC
	b) Horse Power	1 hp
	c) Maximum r min ⁻¹	1500
Gear box reduction ratio		20:1
Pulleys diameter	a) Motor Pulley	74 mm
	b) Gear box driver pulley	74 mm
	c) Gear box driven pulley	126 mm
	d) Blade shaft rod pulley	126 mm
Belt parameter	a) Connecting motor and gear box	B-52
	b) Connecting gear box and shaft	B-75
Hopper parameters	a) Upper Part (Length x Width)	290 mm × 280 mm
	b) Lower Part (Length x Width)	136 mm × 105 mm
	c) Height	130 mm
	d) Capacity of holding peas	2 kg
Weight of machine		105 kg

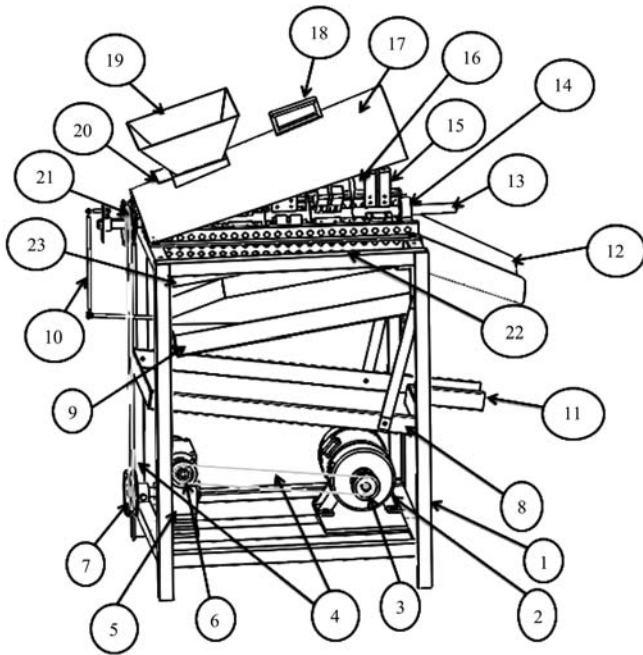

1. Frame 2. Motor 3. Motor pulley 4. Belts 5. Gear box 6. Gear driver pulley 7. Gear driven pulley 8. Second tray 9. First tray 10. Vibration assembly 11. Outlet pea grain guider 12. Trash guider 13. Main shaft 14. Bearing 15. L-shaped blades 16. Conveying blades 17. Upper cover 18. Handle 19. Hopper 20. Hopper plate 21. Main shaft pulley 22. Sieve 23. Side grain guider

Figure 6 Various parts of pea depoding machine

4 Summary and conclusions

In these days, technology has converted hours of work into seconds work. Peas are very popular among people due to its nutritional value. In India and many other countries peas are widely used in dishes during some important occasions such as marriages, functions and parties etc. Manual depoding of peas is a very time consuming task. In view of the non-availability in design and development of a successful pea depoding

machine, a power operated pea depoding machine was undertaken by Punjab Agriculture University, Ludhiana during the period of 2009-2011.

- The machine is quite simple and is capable to extracting large amount of peas in small time.
- Computer aided design of machine was made by using “SolidWorks” software. This design helps to find out the typical dimensions of various components of machine with great accuracy in small time. This design also gives fine representation of pea depoding machine by using simulation.
- A computer aided design helps in better visual inspection of the model and requires changes admitted in model very quickly.
- From analysis, it was observed that 60 r min^{-1} of blade shaft was best suited for depoding of pea from pods.
- The capacity of machine was approximate 30 kg h^{-1} .
- The machine was fabricated by using the low cost material available in local market.
- CAD of machine saves the time of designing of machine as well as provides the accurate dimension which helps to save material. This technology will be surely helpful for the design researchers as it helps to modify their design easily.
- This machine will surely help of farmers by adding the value to agricultural products. In this way, a farmer the income gets better returns for their investment.

References

- Allen, C. A. W., and K. C. Watts. 1998. Design of belt thresher for cowpeabeans. *Agric Mech Asia Afr Lat Am (AMA)*, 29 (3): 42-46, 54.
- Anonymous. 2009a. Production, areas and productivity of Peas in India. National Horticultural Board. Available at: www.indiastat.com. A site registered with main library, Punjab Agriculture University, Ludhiana. Accessed 20 April 2010.
- Anonymous. 2009b. State wise areas, production and productivity of peas in Northern India. Department of Horticultural, Govt. of Punjab. Available at: www.punjabstat.com. A site registered with main library, Punjab Agriculture University, Ludhiana. Accessed 24 June 2010.
- Anonymous. 2010. Vegetable pea varieties. Available at: <http://agropedia.iitk.ac.in/?q=node/737>. Accessed 20 March 2010.

- Bist, B. S. 2010. Contribution of Indian farm Industry for ensuring food security in the country. *Agric Eng Today*, 34 (2): 27-33.
- Gadus, J. 2000. Use of optimization methods in agricultural machine design. *J Res Agr Eng*, 46 (4): 129-132.
- Goyal, N. 2007. Development of modified pea depoding machine. B.Tech. project report, Punjab Agricultural University, Ludhiana, India
- Hulse, L. H. 1994. Nature, composition and utilization of food legumes. In *Expanding the production and use of cool season food legumes*, eds F. L. Muehlbaver and W. L. Kaiser, 97. Kluwer Academic Publishers, Dordrecht, Netherlands.
- Kachru, R. P., R. K. Gupta, and A. Alam. 1994. *Physico-chemical constituents and engineering properties of food crops*. Scientific Publishers, Jodhpur, India.
- Kamboj, P. 2009. Study of farm machinery services provided by selected cooperative societies. B. Tech. project report, Punjab Agricultural University, Ludhiana, India
- Kamboj, P. 2011. Use of computer aided design in development of agricultural machinery. M.Tech. Credit seminar report, Punjab Agriculture University, Ludhiana, India .
- Kaur, S. 2006. Development of pea depoding machine. B. Tech. project report, Punjab Agricultural University, Ludhiana, India
- Kumar, G. 2009. Use of CAD (solid edge) in design and development of multi-crop thresher. B. Tech. project report, Punjab Agricultural University, Ludhiana, India
- Lye, K. P., and I. Y. M. Salleh. 1997. *Analysis of agricultural plough blades using finite element method*. Agric Mech Asia Afr Lat Am (AMA).
- Sharma, S. K., and B. L. Mandhyan. 1988. Development and evaluation of green pea peeler. *J Agric Eng*, 25 (3): 63-68.
- Sharma, S. K., and S. K. Singh. 1989. Design, development and testing of pea shelling machine. Annual Report of AICRP on Post-Harvest Technology, Jabalpur Centre.
- Singh, H. 2009a. Development of solid model of tractor operated rotary weeder. B. Tech. project report, Punjab Agricultural University, Ludhiana, India
- Singh, K. 2009b. Development of solid model of manually operated vegetable seed extracting machine. B. Tech. project report, Punjab Agricultural University, Ludhiana, India
- Singh, M. 2004. Studies on no till seed drill with thrower attachment in combine a straw harvested paddy field. Ph.D. thesis, Punjab agricultural University, Ludhiana, India.
- Singh, P. 2007. Use of CAD in development of prototype of wheel hand hoe mounted twin disc fertilizer broadcaster. B. Tech. project report, Punjab Agricultural University, Ludhiana, India.