

Development and evaluation of metal rolling machine for small-scale manufacturers

R. S. Bello

(Department of Agricultural & Bio-Environmental Engineering Technology Federal College of Agriculture, Ishiagu, 480001, Nigeria)

Abstract: The global drive toward intermediate technology and sustainable development motivated the development of sheet metal rolling machines for small-scale artisanal manufacturers. This paper presents the design, construction and evaluation of a sheet metal rolling machine for small-scale enterprises. The machine consists of three rollers; a rigid forming roller, a free floating roller and a drive roller arranged triangularly with two handles for shape-rolling. The rollers were made of galvanized metal pipe, 1,050 mm long, 76 mm diameter, each approximately, 3 mm thickness; a driving shaft 1,220 mm long, 16.6 mm diameter and 4 pieces of mild steel washers to provide support to shaft and also to limit the bending stress on the rollers. The entire system is mounted on a metal frame made from angled-iron bars which were secured in place with 19 mm bolt and nuts. The clamping and folding bearing blocks are 120 mm thick, the throat width is 1,200 mm, and maximum length capacity of the machine is 1,050 mm. The best roller aperture for material tested is 5.5 mm and maximum bend radius of 2.5 mm. The maximum length of material that gives the best circular shape is 620 mm. The average percentage acceptance of the machine by the artisan is 70.59% ($n=24$) indicating that the technology is acceptable. Fifteen percent of the welders and 40% of tinsmiths are well acquainted with the functions of the machine. A total of 73.53% ($n=26$) of the respondents are not acquainted (technology awareness) with the shape rolling technology while 26.47% ($n=9$) have a fair knowledge of the use of such machines in metal rolling. The whole machine has a very small footprint, making it ideal for the home workshop and small factory alike.

Keywords: metal rolling, bushing, bearing block, capacity, bending load

Citation: Bello, R. S. 2013. Development and evaluation of metal rolling machine for small-scale manufacturers. *Agric Eng Int: CIGR Journal*, 15(3): 80–85.

1 Introduction

Sheet metal fabrication plays an important role in the metal manufacturing world (Cloutier, 2000). Sheet metal is used in the production of materials ranging from tools, to hinges, automobiles etc. Sheet metal fabrication ranges from deep drawing, stamping, forming, and hydro forming, to high-energy-rate forming (HERF) to create desired shapes (Cloutier, 2000). Fascinating and elegant shapes may be folded from a single plane sheet of material without stretching, tearing or cutting, if

one incorporates curved folds into the design (Martin et al., 2008).

Shape rolling of sheet metal is the bending continually of the piece along a linear axis. This causes alteration of the original form of the sheet as it passes through a pathway of series of rollers. Such work tool as shape rolling machine is found to be very useful in manufacturing processes for used parts in various industries like inner and outer panels and stiffeners in automotive and agricultural industries, small metal workshops to roll round and conical profiles for stoves, cylinders (flue pipe, water pipes), basic machine elements with curved surfaces, buckets, bins, gear box cover, mud guards, drinkers and feeders for poultry, feed mixers etc. and also in food cans and civil engineering applications. A wide range of these products should satisfy tight

Received date: 2010-08-27 **Accepted date:** 2013-08-02

Corresponding author: R. S. Bello, Department of Agricultural & Bio-Environmental Engineering Technology Federal College of Agriculture, Ishiagu, 480001, Nigeria. Email segemi2002@yahoo.com.

tolerances compared to desired geometry (Behrouzi *et al.*, 2008).

The local artisans and craftsmen are the known major producers of simple farm tools and equipment in Nigeria while the small scale welders had been found to have the highest farm tools and equipment production potentials in Nigeria (Yiljep, 1999); however, inadequate production facilities and lack of appropriate reconditioning tools and equipments, are some of the major problems faced by these local manufacturers (IFAD, 1988).

The identification, selection, design desirability, and promotion of locally modified tools is made possible through the strengthening and redesigning of machine vital components, the improvement of welder's craftsmanship and adequate enhancement of local manufacturing processes through the use of locally improved work tools and machines.

A critical appraisal of locally available metal rolling machines indicated a necessity of improving on ergonomic design, system complexity and cost (Bello, 2012). Rob (1985) published a work based on the report of the Intermediate Technology Development Group (ITDG) on the development of rolling machine for sheet metal work. The complexity of the crank mechanism, the numerous and intricate component parts of the machine defeated the aim of simple technology tool development and manufacture. The machine rolls sheet metal up to 1.5 mm thick and 1m wide and rolls complete cylinders down to 75 mm diameter with 55 mm diameter rollers.

Considering high cost of tools and products in sheet rolling processes, detection and controlling factors for producing precise product are important. In most processes, geometry and configuration of rolling components could be obtained from the geometry of product at the end of loading. Therefore elastic recovery (known as spring back) formed part of the unloading process, and it is the most important factor in deviation of final products from desired geometry. Spring back is influenced by a combination of various process parameters such as tool shape and dimension, contact friction condition, material properties, thickness, etc. (George, 1983; Cho *et al.*, 2003). This work therefore

reported the design and evaluation of a simplified shape rolling machine with simple crank mechanism, higher diameter of roll (up to 200 mm), spring loaded bearing blocks for stress relief when load is overbearing (machine handling a load beyond the designed safety factor and load carrying capacity), low cost and for varying roller aperture for easy sheet metal rolling.

2 Design considerations

2.1 General design principles

Following basic shearing operation on a sheet metal, components can be rolled to give it a definite shape. Bending of parts depends upon material properties at the location of the bend. To achieve bending, the work material must be subjected to two major forces; frictional force which causes a no-slip action when metal and roller came in contact and a bending force acting against the forward speed and the torque applied to move the material (Figure 1).

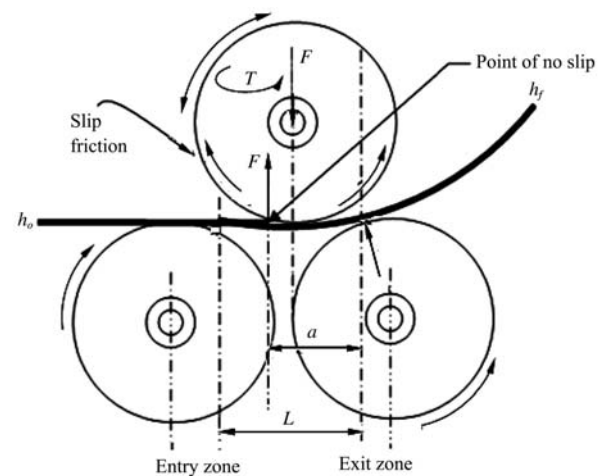

where, a = distance from exit zone to the no-slip point (assume $a = L/2$); F = force applied to rollers; T = torque applied to rollers; L = roll gap; r = radius of rollers; μ = frictional force 0.4 Nm^{-1} ; h_o, h_f = thickness of the sheet before and after time t .

Figure 1 Shape rolling mechanism

At least two rollers were involved in flat rolling depending on the thickness and properties of material while three or multiple roller system is required in shape rolling. A work material under bending load is subjected to some form of residual stress and deformation as it bends. Materials at the outer bend radius undergo tensile plastic deformation while the material at the inner bend radius undergoes compressive plastic deformation.

The width along the bend radius will reduce in length based on Poisson's ratio and if the bend radius is too small, the plastic deformation at the outside of the bend results in fracture. The limit to which such material can be bent is evaluated by the following Equation (1) given by Jack (2003):

$$L_b = \theta(r + \kappa T) \quad (1)$$

where, L_b = bend allowance; θ = bend angle; r = bend radius to neutral axis; k = constant for material, for $r < 2T$; $k = 0.33$; for $r > 2T$, $k = 0.5$, T = thickness of material.

The strain on the outermost fibers of the bend is evaluated by Equation (2) given by Jack (2003):

$$\varepsilon = \frac{1}{\left(\frac{2r}{T} + 1\right)} \quad (2)$$

Maximum bending force is calculated by Equation (3) given below (Jack, 2003):

$$\frac{\sigma_{yield} L T^2}{W} = \frac{\sigma_{UTS} L T^2}{W} \quad (3)$$

where, P = maximum bending load; k = constant for particular die from 0.3 to 0.7; σ_{yield} = yield stress for material; σ_{UTS} = ultimate tensile stress for the material; L = length of bend (along bend axis); w = distance between reaction supports

When the rollers are in contact with the load, there is a frictional force existing, and an applied force, F and a slip between rollers and the load, which is not constant over the entire surface area of contact (Wagoner and Li, 2007).

An assumption of no reduction in size of material thickness during rolling makes, the thickness uniform i.e. and for small diameter bending, $a = L$. For large diameter bending $L > a$. Thus the maximum force is given by Hugh (2003) as (Equation (4)):

$$\mu^2 r = h_f - h_o = \text{Maximum draft} \quad (4)$$

where, μ = frictional force 0.4 Nm^{-1} ; h_o , h_f = thickness of the sheet before and after time t .

Analytical solutions of bending process have been presented by several researchers (Dongjuan *et al.*, 2007; Kim *et al.*, 2007; Wagoner and Li, 2007); however, for inverse analysis of springback in free bending process, a state of plain strain and negligible shear deformation is assumed (Behrouzi *et al.*, 2008). Considering the two

strain components; the elastic strain (ε_e) and plastic strain (ε_p), the total axial strain (ε_x) can be written as Equation (5):

$$\varepsilon_x = \varepsilon_e + \varepsilon_p = \frac{(1 - V^2)\sigma_x}{E} + \varepsilon_p \quad (5)$$

where, ε_x = total axial strain; ε_e = elastic strain; ε_p = plastic strain; E = Young's modulus, V = Poisson's ratio.

Required bending moment (M) can be calculated as Equation (6):

$$M = \int_A \sigma_x y dA \quad (6)$$

where, A = area of shaft; σ_x = axial stress; y = radial arm in mm.

Axial strain (ε_x) can be obtained as Equation (7) and Equation 8 assume axial stress ($\sigma_x = 1$):

$$\varepsilon_x = \frac{2}{t} \int_{y_c}^{t/2} \varepsilon_p dy + \frac{24y}{t^3} \int_{y_c}^{t/2} \varepsilon_p y dy + \frac{12M(1 - V^2)y}{Ebt^3} \quad (7)$$

$$\sigma_x = \frac{2E}{(1 - V^2)t} \int_{y_c}^{t/2} \varepsilon_p dy + \frac{24y}{t^3} \int_{y_c}^{t/2} \varepsilon_p y dy + \frac{12My}{bt^3} - \frac{E\varepsilon_p}{(1 - V^2)} \quad (8)$$

where, b and t are width and thickness of the sheet respectively; ε_e = elastic strain; ε_p = plastic strain; E = Young's modulus and V = Poisson's ratio.

Bend radius after springback can be written as Equation (9):

$$\rho' = \frac{1}{\frac{1}{\rho} - \frac{12M(1 - V^2)}{bt^3 E}} \quad (9)$$

where, ρ and ρ' are bending radius before and after springback respectively.

Knowing the thickness and width of sheet plate and considering material's behaviour, analysis of V-bending for various bending angle and radius become possible.

The power required to roll the material is given by Equation (10)

$$P = \text{force} \times \text{velocity} = (Lw\gamma_{ave}) \times (2\pi rn) \quad (10)$$

where, P = power in watts required to roll the sheet and n = speed in rmin^{-1} .

The spring back effect in bending is compensated by the following Equation (11) (Jack, 2003).

$$\frac{\sigma_{before}}{\sigma_{after}} = 4 \frac{(r_{before} \sigma_{yield})^3}{ET} - 3 \frac{r_{before} \sigma_{yield}}{ET} + 1 \quad (11)$$

where, $\sigma_{before} = \sigma_{after} = 1$ for flat sheet; ε = Bending strain.

2.2 Machine description

The major design components consisted of three rollers supported on spring loaded bearing blocks mounted on a frame (Figure 2).

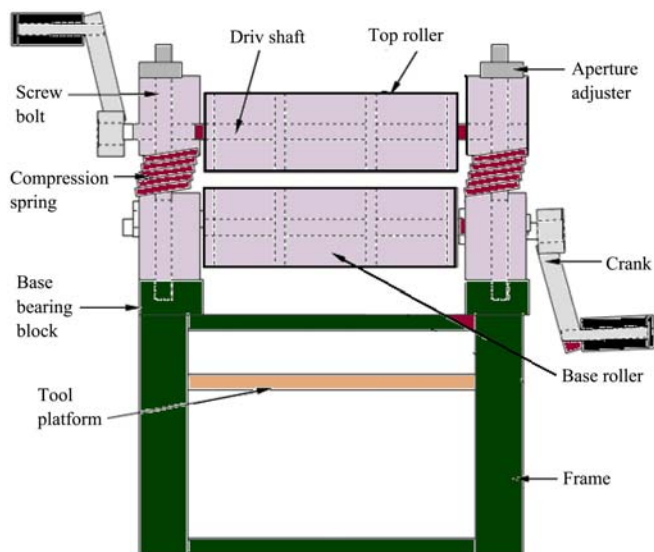

Figure 2 Schematic drawing of the machine

The rollers were arranged in triangular form; two sets of rollers below and one above. The upper roller provide the bending force while the back base roller provides the required driving force and the front end roller bends the metal according to set radius of bend. Two base bearing blocks (made of hard wood) mounted on the frame provided supports for the base rollers while the press roller is supported by two wooden bearings blocks, and mounted on a U-shaped metal bracket (Figure 3).

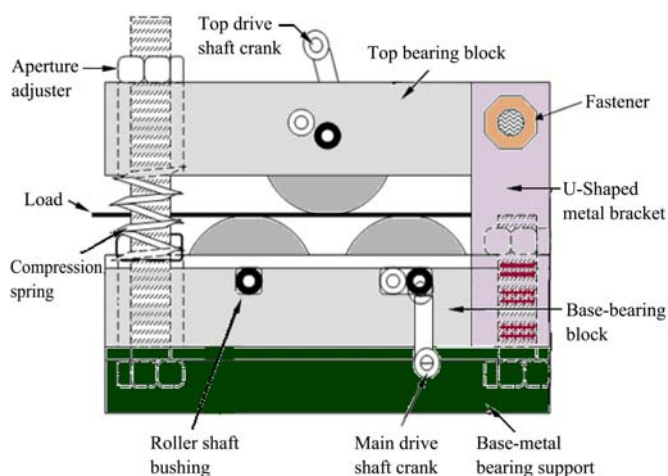

Figure 3 Bearing block assembly

The clamping beam is spring loaded (using old car

valve-springs) to simplify positioning and radius adjustment on the sheet. The clamping beam is also fully adjustable fore and aft by means of two threaded knobs, which results in very accurate bends. The shaping beam is simply supported and has a well-positioned stout drive handle.

Aperture adjuster on each block assembly ensures easy loading of work piece and adjustment to required radius of bent. The free end of the top bearing block is spring loaded to increase or to reduce top-base roller clearance. Two other bores on each bearing blocks provide an adjustment for the roller gap variability thereby making it possible to roll sheet metal to different sizes. The top roller provides the bearing load (bending force) and also compliments the driving roller when working on thick materials. The lower back roller provides the necessary driving forces while the idler roller does the bending and material delivery.

There are two crank levers, one on the top roller and another on the front-end roller. The lever (handle) coupling head has a square configuration which fits into the square end of the roller shaft. The frame structure is made of (50×50×5) mm angle iron for the purposes of strength. The height of the entire machine when mounted on the frame is 800 mm. This height is convenient for operators of an average height of 1,680 mm. A tool table is provided below the rollers for safe keeping of tools and cranks. The roller head assembly is detachable from the frame and can be mounted on a table to be used as a table top machine for tinkering works.

2.3 Performance evaluation

Performance evaluation of the fabricated machine was carried out in the Department of Agricultural & Bio-Environmental Engineering Technology workshop of the Federal College of Agriculture, Ishiagu. The field test was performed with four randomly sampled welders and tinsmiths selected within the local government area. The capacity of the machine was evaluated based on the maximum width of strips of metal that can be rolled without exceeding the designed maximum bearing load and the numbers of operators required to conveniently operate the machine without overbearing efforts. Maximum length capacity of the machine is determined

by the width of material that can conveniently be passed through the aperture without difficulty. The roller aperture is determined by the maximum size opening between the three rollers when aligned axially. The percentage acceptance is determined from the analysis or respondents acceptability of the adapted technology.

3 Results and discussion

Table 1 shows the general relations between the roller apertures; roll gap (the space between each set of rollers),

the bend radius of material and the type of shape formed. The result indicates the maximum bend radius obtainable as an approximate radius of roller for a typical material length of 620 mm is 2.5 mm. The largest measured diameter of complete cylinder the machine can handle (roll) is 184 mm using the given diameter of rollers. At reduced roller aperture of 2.5 mm, the material folded over and the radius of cylinder reduced. This result showed a remarkable improvement over Rob's report of 75 mm diameter.

Table 1 Results of aperture, roll gap and the bend radius test

Roller diameter	Roller aperture (before bending) /mm	Roller aperture (after bending) /mm	Roll gap /mm	Bend radius /mm	Shape formed	Material length /mm
76mm	10	8	2	120	Semi circular	620
	8	5.5	2.5	92	Complete circle	
	6.5	2.5	3	50	Double folded circle	

The fabricated machine is as shown in (Figure 4) below under test. The maximum bend radius when the aperture is closed is approximately the circumferential distance round the roller. The springback effect on the rolled plate is noticeable as the rolling aperture decreases and the bend radius considerably decrease. This effect can be increased by stretching out the material as it rolls or increasing the aperture width. Alternatively, variable roller diameters could be used when handling materials of varying length. Other dimensions can be obtained by varying the width of aperture until the bend radius approaches a straight line depending on the length of work material. The maximum width of material that can be handled with significant bend radius is, 1200 mm and the length is 620 mm.



Figure 4 Front view of the machine

The maximum width (machine capacity) of strip of material the machine could handle is 1,050 mm for

tinplates and mild steel with thickness not exceeding 2 mm. When the machine was used to roll mild steel plate of 2.5 mm thickness, the bearing blocks showed evidence of possible failure. The wooden bearing blocks could not support the bending stress exerted by the materials with higher thickness than 2 mm and as a result the machine usage can only be restricted to light gauge metal work and thus find use in tinsmith and welding workshops. Slip friction in rolling was eliminated between the rollers and the load by keeping the contact surfaces smooth and free of lubricants and dirt.

The average number of operators required to operate the rollers at a given operation is shown in Table 2 with their average weights. Material thicker beyond 2 mm requires two operators while 3 mm thickness material could not be conveniently roll due to the required bending force and the strength of the material used in construction. The bearing capacity of wood cannot support such material thickness.

Table 3 indicates the level of involvement and acceptance of the intermediate technology employed in the development and ease of operation of the machine. The average percentage acceptance of the machine by the artisan is 70.59% ($n=24$) indicating that the technology is acceptable. Fifteen percent of the welders and 40% of tinsmiths were well acquainted with the functions of the machine. A total of 73.53% ($n=26$) of the respondents are not acquainted (technology awareness) with the shape

rolling technology while 26.47% ($n=9$) have a fair knowledge of the use of such machine in metal rolling.

Table 2 Table of performance tests

Material	Material thickness/mm	No. of operators	Ave. wt. of operator/kg	Maximum width of work/mm	Length of material/mm
Aluminum plate	3.00	1	65.00	1050.00	1200.00
	≈1.50	1	65.00	1050.00	1200.00
Galvanized plate	1.00	1	71.00	≈525.00	800.00
	2.00	2	68.9	≈525.00	800.00
Mild steel plate	1.00	1	65	1050.00	1200.00
	2.00	2	72.00	500.00	600.00
	≈3.00	2	72.00	300.00	400.00

Table 3 The level of technology awareness and involvement

Artisan	Total number	Acceptance/%	Non-acceptance/%	Technology awareness/%	Technology non-aware
Welders	20	65 (13)	35 (7)	15 (3)	85 (17)
Tinkers (tinsmiths)	9	78 (7)	22 (2)	40 (~3)	50 (~6)
Fabricators	5	85 (~4)	15(~1)	67 (~3)	33 (2)
Average (total)/%	100 (34*)	70.59 (24)	29.41 (10)	26.47 (9)	73.53 (26)

Note: (*) = Total number of respondents tested. The results in the table should be explained further.

These results indicate that such rolling machines are not available within the Local Government Area. The total cost of the machine is estimated at N20,000.00 including the cost of production. Market survey indicates that the cost of imported shape rolling machine ranges from N380,000.00-N500,000.00 while locally fabricated low capacity shape rollers are valued at between N60,000.00 and N80,000.00.

4 Conclusion

The shape rolling machine is very efficient in rolling curved sections. The machine is cost effective based on the materials of production and simplicity of the design of component parts. Operational mode meets the level of technical knowhow of the artisans.

References

- Behrouzi, M., B. Shakeri, and Mollaei Dariani. *EngOpt 2008 - International Conference on Engineering Optimization. June 1-5, 2008: Inverse Analysis of Springback in Sheet Metal Forming by Finite Element Method.* Rio de Janeiro, Brazil.
- Bello, R. S. 2012. *Workshop Technology & Practice.* South Carolina, US: *Createspace.*
- Cho, J.R., S.J. Moon, and S.S. Kang. 2003. Finite Element investigation on Springback Characteristics in Sheet Metal U-bending Process. *Journal of Materials Processing Technology*, 141(1): 109-116.
- Cloutier, M. 2000. *Sheet Metal Fabrication. ME 353 Instructor: Jesse Adams. Smf.pdf.* modified May 15th 2010.1-18.
- Dongjuan, Z., C. Zhenshan, R. Xueyu, and L. Yuqiang. 2007. An analytical model for predicting springback and side wall curl of sheet after U-bending. *Computation Materials Sci.* 38(2): 707-715.
- George, L. 1983. *The theory and practice of metal work.* 3rd edition. *PTF low price edition.* Longman, London
- Hugh, J. 2003. *Engineer on a Disk.* <http://claymore.engineer.gvsu.edu/eod/global/copyright.html>. © 1993-2001. 15 July, 2008...
- IFAD. 1988. *Generation and transfer of Technology to poor small farmers. Issues and options, kesseba and Jazairy.* Rome: Appropriate Technology International.
- Kim, H., N. Nargundkar, and T. Altan. 2007. Prediction of bend allowance and springback in air bending. *ASME- J. Manufacturing Sci. Eng.* 129:342-351.
- Kilian, M., S. Flory, Z. G. Chen, N. J. Mitra, and A. H. Pottmann. 2008. Curved Folding. *ACM Trans. Graphics.* 25 (3): 681-689.
- Hitchings, R. 1985. *How to make a rolling machine for sheet metal work. Intermediate Technology Publications.* Nottingham: Betrand Russel House.
- Yiljep, T. P. 1999. Characterization of major Agricultural Tools manufacturing Artisans in Northern Nigeria. *Journal of agric. Eng. & Tech.* 7: 45-52.
- Wagoner, R. H., and M. Li. 2007. Simulation of springback: through-thickness integration. *International Journal of Plasticity*, 23(3): 345-360.