

Development and evaluation of a solar powered rice packaging machine

O.O. Nwoke¹, O.Ojike¹, A.P. Onwualu², W.I. Okonkwo¹

(1. *National Centre for Energy Research and Development University of Nigeria, Nsukka;*

2. *Raw Materials Research and Development Council, Abuja.*)

Abstract: To enhance the marketability of locally produced rice in Nigeria, a machine for cutting and sealing polythene for rice packaging was developed. The machine incorporates a regulator switch which ensures that current flows to the heating element only when the pedal which operates the sealing is matched. This feature reduces the energy requirement of the machine as well as prolongs the life of the heating element. This energy saving feature makes its adaptability to solar photovoltaic (PV) power cheaper than conventional sealing machines where currents flows through the heating element all the period the machine is on. The electrical power requirement of the machine is 84 Watts with a nominal voltage and current of 24 Volts (dc) and 3.45 amps respectively. For poor weather conditions when “peak sun hours” are as low as three hours, it can be powered by two 55 W (peak) PV modules connected in series. It can also be powered by 220 Volts (ac) source intercepted with a step down current transformer (CT) of 100 Volts-Ampere. ‘Leak Proof Test’, ‘Fall Impact Test’, ‘Compressive Test’ and ‘Grain Quality Assessment’ were performed to evaluate ‘Effectiveness of Packaging’. Results obtained were considered satisfactory for practical applications. The theoretical capacity of the machine is 720 bags/hour while its actual capacity depends on the operator of the machine.

Keywords: solar power, rice, packaging, machine, marketability, polythene, solar photovoltaic, Nigeria

Citation: Nwoke O.O., O. Ojike, A.P. Onwualu and W.I. Okonkwo. 2011. Development and evaluation of a solar powered rice packaging machine. *Agric Eng Int: CIGR Journal*, 13(1): —.

1 Introduction

One of the major challenges of marketing locally produced rice in Nigeria is acceptability (Daramola, 2005). It is generally known that most Nigerians prefer foreign made goods then locally produced goods. For rice, some people will cite reasons ranging from ‘stone free’ to ‘attractiveness of grains’ as basis for preferring foreign rice. Others who are mere crowd followers just see it as a ‘mark of class’ and enhanced social status to be associated with foreign made goods even if the locally made ones are of similar quality as the foreign made.

According to Paine and Paine (1992), packaging is a coordinated system of preparing goods for transport, distribution, storage, retailing and end use. At its most

fundamental, packaging contains, protects, preserves and informs. At its most sophisticated, it provides the functions of selling and convenience. Paine and Paine (1992) also felt that the only difference between competitive brands lies in the packaging and only packaging influences the selling operation. Packaging also enhances brand confidence. The marketability of locally produced rice could be enhanced by quality packaging.

It is well known that consumers prefer to purchase standardized products when packaged in a uniform manner designated by a recognizable brand title. Packaging in ‘portion’ packs often helps the consumer to buy the quantity needed and no more. Packaging small quantities which are affordable has recently boosted sales for many products which hitherto were not so. Packaging of drinking water as sachet water and packaging of table salt in small polythene sachets are

Received date: 2010-03-18

Accepted date: 2011-01-29

Corresponding author: W.I. Okonkwo, email: okalanwoke@yahoo.com

examples (Nwajei, 1998). Nigerian locally produced rice could be packaged in quantities of 500 g (2 cups) and 1 kg (4 cups) in branded, transparent and strong polythene film bags. This could boost the marketability of locally produced rice and thus encourage local producers.

According to Brydson (1977), polythene, is a wax-like thermoplastic, softening at about 80°C to 130°C with a density less than that of water and was first produced on a commercial scale in 1939. Polythene comes in two different forms – the high density grade (HDG) polythene and the low density grade (LDG) polythene. The difference between the two is in their chemical composition (Raymond and Charles 1972).

A machine for cutting and sealing polythene for rice packaging has been developed from locally sourced materials. One major advantage of the machine over existing polythene cutting machines is the incorporation of a regulator switch in the electrical system of the machine. The machine thus uses lower quantity of electrical energy for a given number of operations compared to the already existing machines. This mechanism also ensures a prolonged life span for the heating element. Where grid feed electricity is unavailable or unreliable, the machine can be powered by a solar photovoltaic system or a charged battery system.

2 Materials and methods

2.1 Machine description

The machine consists of a number of units namely: the cutting and sealing unit, drive mechanism, frame and electrical system. As shown in Figure 1 the cutting and sealing unit is made up of a heating element and foam that aids uniform distribution of pressure. The length of the heating element which is the same with that of the foam strip is 72 cm. This length was chosen due to the fact that no single package length could be more than this. The foam is overlaid with a heat resistant material called Teflon. This is to avoid the burning of the foam under intense heat from the heating element. As the element is heated by the passage of current, its temperature rises therefore making it to expand and sag. This can lead to uneven cutting and sealing operation. It can equally

cause the rupturing of the element. To check this, a switch regulator is connected within the circuit as shown in Figure 1. This limits the time in which current passes through the element. With this measure, only the heat required for cutting and sealing is generated and the unwanted sagging effect is reduced to the barest minimum. Thus, the switch regulator helps to save energy and to prolong the life of the heating element which is an improvement on what is already in existence.

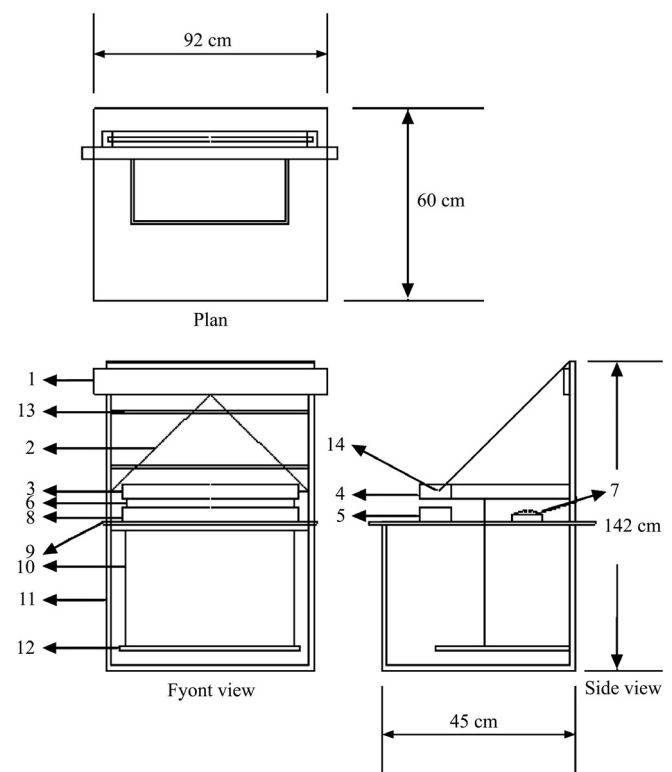

1. Face board 2. Rubber band 3. Nail hook 4. Arm 5. Asbestor 6. Twine
7. Regulator switch 8. Foam Strip 9. Sealing Platform 10. Twine
11. Metallic Frame 12. Pedal 13. Cross bar 14. Heating element.

Figure 1 Polythene cutting and sealing machine

The drive mechanism consists of pedal, twine and arm on which the heating element is connected. As shown in Figure 1, the pedal is connected to the arm by a twine and the position of the arm is controlled with a rubber band. Underneath the arm is a heat resistant material called asbestos which protects the arm from being burnt by the heating element when it is red hot. The pedal measures 72 cm and runs through the length of the sealing table to aid operation from any sitting position on the sealing Table. A picture of the prototype of the developed machine is presented in Figure 2.



Figure 2 Picture of the prototype of the rice packaging machine

The frame consists of 2.54 cm cast iron, square pipe, cut and welded to form the structural frame work on which the face board and sealing platform made of plywood are fixed. Dimensions of the sealing table shown in Figure 1 where primarily chosen to enhance the comfort of the operator in a sitting position and for ease of operation.

The electrical system consists of photovoltaic modules and accessories, battery bank, regulator switch and heating element.

2.2 Power requirement

2.2.1 Load characterization

A maximum of 130°C is required to melt both HDG and LDG polythene (Brady, Clauser and Vaccari, 2002). The constantan heating element used in the machine measures 70 cm with a cross sectional diameter of 0.46 mm. The density of constantan is given as $8.9 \times 10^3 \text{ kg/m}^3$ (Kundig, 2002). So that mass is 1.035 g.

The constantan heating element needs to be at least 130°C. However 200°C above the ambient temperature was chosen to give a good factor of safety with respect to cutting and sealing. Therefore the heat required to be generated in the heating element can be estimated from Equation (1);

$$H = m c (t_2 - t_1) \tag{1}$$

Where, H is heat, J; m is mass of the constantan element,

kg; c is specific heat capacity constantan, J/(kg·K); t_1 is ambient temperature, K; and t_2 is required element operating temperature, K.

Assuming t_1 and t_2 to be 30°C and 230°C respectively, with c given as 390 J/(kg·K) (Kundig, 2002), the required heat was calculated to be 81 Joules. The required current in the heating element is estimated from Equation (2).

$$I_L^2 R t = H \tag{2}$$

Where, I_L is load current, A; R is heating element resistance, Ω ; and t is time, s.

The load current was calculated to be 3.45 amps. Laboratory characterization of the heating element shows that the element is heated in one second and its measured resistance is 6.8 ohms. Therefore the required potential difference across the element is 23.5 Volts from Equation (3).

$$\frac{v^2 t}{R} = H \tag{3}$$

Where, v is potential difference across the heating element, V.

The electrical power requirement of the machine was calculated to be 83 Watts from Equation (4).

$$P = I_L \times V \tag{4}$$

Where, P is the power in watts.

2.2.2 Photovoltaic (PV) array sizing

The ampere-hour method of sizing PV arrays is recommended for stand-alone systems (Steven and William, 1991) of which this sealing machine with its PV power unit is an example. It was assumed that it will work for a maximum of 12 hrs in a day. From operating the machine, it was found that the minimum time interval for two successive seals is four seconds while one second is used for the seal formation. In the end, a minimum of five seconds is used for each sealing operation. Therefore if the machine is in operation for 12 hrs, the accumulated time in which the current passes through the element is 2.4 hrs. The salient characteristics of the machine to enable PV sizing is summarized below:

Load current (I_L)	Hours each day (t_0)	Days per week (W_d)	Average ($I_L \times t_0 \times W_d$)
3.45 A	2.4 hrs	6/7	7.1 Ah/day

Assuming 10% of power loss from wiring, the average daily usage becomes 7.89 Ah/day. The required current from the PV modules is calculated from Equation (6).

$$I_p \times SH = I_L \times W_d \quad (6)$$

Where, I_p is Current from modules, A; and SH is Peak sunshine hours, hrs.

Data from a meteorological station at Nsukka, Nigeria (Latitude 7°N approximately) show that three hrs of peak sunlight can safely be obtained by a surface tilted to the horizontal at the local latitude angle facing south. I_p was calculated to be 2.63 A. The number of modules required to be connected in parallel is given by Equation (7).

$$N_p = \frac{I_p}{I_m} \quad (7)$$

Where, N_p is number of modules to be connected in parallel; I_m is module current at maximum power point

The 55 watts peak (W_p) power Siemens made PV module has current and voltage at the maximum power point as follows:

Module current at maximum power point (I_m) = 3.15 A.

Module voltage at maximum power point (V_m) = 17.4 V

The number of modules (N_s) required to be connected in series is given by Equation (8) as:

$$N_s = \frac{V_s}{V_m} \quad (8)$$

Where, V_s is the system voltage and had been determined to be 24 V approximately. Results obtained with Equation (7) are usually rounded up to the nearest whole number. Therefore two modules connected in series are required to power this machine.

2.2.3 Battery sizing

In the ampere-hour method of sizing a PV system, the number of batteries required is given by Equation (9).

$$B_t = B_p + B_s \quad (9)$$

Where, B_t is total number of batteries required for storage; B_p is number of batteries in parallel; and B_s is number of batteries in series.

The number of batteries required in parallel (B_p) is determined from Equation (10).

$$B_p = \frac{D_L \times N}{M_D \times C_B} \quad (10)$$

Where, D_L is daily load (Ah); N is number of “no sun days”; M_D is maximum depth of discharge of battery (decimal); and C_B is Capacity of battery at a given discharge rate and given temperature (Ah).

The number of batteries calculated with Equation (10) is always rounded up to the nearest higher whole number if a decimal number results. The daily depth of discharge is checked at this stage to ensure that the daily discharge does not exceed the manufacturer’s recommendation. This is done by dividing the daily load by the total battery capacity connected in parallel and then comparing the obtained result with the recommended.

The number of batteries in series (B_s) is calculated with Equation (11).

$$B_s = \frac{V_s}{V_b} \quad (11)$$

Where, V_s is the systems voltage earlier stated and V_b is the nominal voltage of each battery.

Using three days as ‘N’ which is typical in the month of July in Nsukka and 0.6 as ‘ M_D ’, two 60 Ah 12 V *prostar* made deep cycle batteries connected in series were found sufficient to adequately meet the machine’s power requirement.

The machine can also be powered by an AC source of 220 volts but must be conditioned with a step down current transformer (CT) of 100 VA. A picture of the PV modules is shown in Figure 3.



Figure 3 Picture of the Solar PV modules

3 Performance evaluation

3.1 Power adequacy test

To evaluate the performance of this machine, tests bothering on the power adequacy and effectiveness of packaging were carried out. The two 60 Ah 12 V *prostar* made deep cycle batteries were connected to the PV modules and charged fully. The PV modules were then disconnected from the batteries and the batteries used to power the machine for three days without the PV modules. This was done to check the adequacy of the specified battery size in the event of three consecutive rainy days. The machine, with the PV modules and batteries were also tested in the month of July, which tends to have the least in monthly averages of solar radiation in Nsukka.

3.2 Effectiveness of packaging

To evaluate the effectiveness of the packaging, the following tests were considered necessary:

a) Leak Proof Test: low density grade (LDG) and high density grade (HDG) polythene were used to package 250 g, 500 g, 750 g and 1 000 g of water. Each weight had three replications. The packaged water was weighed and reweighed after 24 hours. The mean of the differences in weights was compared to zero (100% leak

proof). Difference of the two means was tested at 5% significance level.

b) Fall Impact Test: different quantities (0.5 kg, 1 kg, 1.5 kg and 2 kg) of locally produced rice known as Adani rice were packaged in LDG and HDG polythene. Three replications of each package were allowed to fall from different heights under gravity to a predominately sandy ground. This test is necessary in establishing the maximum height from which packaged rice can fall without rupturing in the event of loading and off loading.

c) Compressive Test: three replications of 0.1 kg packaged rice in LDG and HDG polythene were each subjected to a compressive test in *Hounsfield Tensometer*. Compressive test is necessary to evaluate the maximum static stack a packaged quantity can carry without rupturing.

d) Grain Quality Assessment: packaged rice in LDG and HDG polythene were left in shelves typical of grain vendors' shelf. A shelf life of six months was considered adequate since the packaging was primary done to enhance marketability and invariably undergo short time storage on traders shelf. Selection of typical shelves and assessment of grain deterioration was highly subjective. Pictures of the packaged rice are shown in Figure 4.



a



b

Figure 4 Samples of the packaged rice

3.3 Production capacity

The theoretical capacity of this machine is calculated using the assumption that it takes a minimum of five

seconds to seal a bag. Therefore in one hour, 720 bags would have been sealed. The actual capacity of this machine would vary for different operators depending on

the operator's stamina and skill.

4 Results

4.1 Power adequacy test

The fully charged batteries were able to power the machine without the PV modules for three days. In each day, the machine was operated for 12 hours. The machine also performed satisfactorily with respect to power supply in the month of July when monthly radiation tends to be very low in Nsukka.

4.2 Effectiveness of packaging

a) Leak Proof Test: the cut and sealed polythene bags were evaluated to calculate degree of tightness of the formed seal with respect to fluid retention. This was done by filling the bags with water and weighing in an electronic balance. The readings obtained after a 24-hour period with variance calculations are as shown in Table 1.

Table 1 Leak test of low density grade polythene

S/No	Initial weight /g	Final weight /g	Weight loss /g[x]	$x - \bar{x}$	$(x - \bar{x})^2$
1	250	250	0	-0.33	0.11
2	250	250	0	-0.33	0.11
3	250	250	0	-0.33	0.11
4	500	499	1	0.67	0.45
5	500	500	0	-0.33	0.11
6	500	500	0	-0.33	0.11
7	750	749	1	0.67	0.45
8	750	750	0	-0.33	0.11
9	750	749	1	0.67	0.45
Total			3	2.01	

From the Table 1, variance $\frac{\sum(x - \bar{x})^2}{n} = 0.22$, so that 'leakage' standard deviation = 0.47. Using the 'Student's t-test' to compare the mean weight loss (leakage) to an ideal mean of 'zero' weight loss, the calculated value of 'T' is gotten from Equation (12).

$$T = \frac{(\sqrt{n-1})(\bar{x} - u)}{s} \quad (12)$$

Where, n is sample size; \bar{x} is leakage mean; u is ideal mean; and s is leakage standard deviation.

From "Table of Critical Values of t*" (Obi, 2002), the value of t* for a two-tailed test at $(n-1)$ degrees of

freedom and 0.05 level of significance is 2.306. From equation 12, T is calculated as 1.99. It therefore follows that there is no significant difference at 0.05 level between the initial recorded weights and the weights after the 24-hour period since the calculated value of T is less than the tabulated value. A similar test was also carried out with the high density grade polythene. Results also showed no significant difference at 0.05 level between the initial and final weights after 24 hours.

b) Fall Impact Test: different packaged quantities of rice were allowed to fall from different heights to a ground surface characterized as predominantly sandy. The heights at which the different packaged quantities ruptured are summarized in Table 2 and Table 3 for the LDG and HDG polyethylene respectively. The "height" as shown in the tables represents the average height at which three replications of each of the represented packaged rice weights ruptured in the free fall test.

Table 2 Height of rupture for different weights of rice packaged with LDG

Weight/g	Height/m
500	2.00
1 000	1.63
1 500	1.00
2 000	0.75

Table 3 Height of rupture for different weights of rice packaged with HDG

Weight/g	Height/m
500	2.50
1 000	2.00
1 500	1.75
2 000	1.40

c) The compressive test performed with *Hounsfield Tensometer* on three replications of 0.1 kg of rice packaged differently in LDG and HDG polythene ruptured at average compressive forces of 2 500 N and 4 600 N respectively over a disc of 0.06 m diameter. Average values of the forces and deformations for the three replications are shown in Figure 5 and 6 for the LDG and HDG polythene respectively.

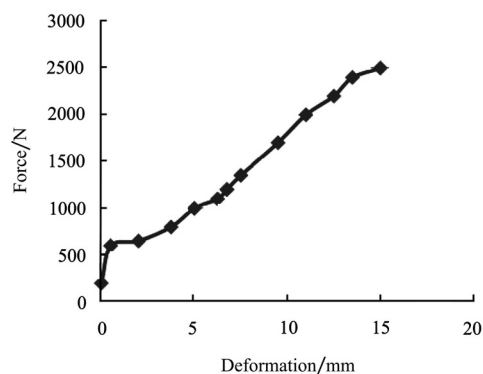

Figure 5 Graph of force-deformation for LDG polythene packaged rice

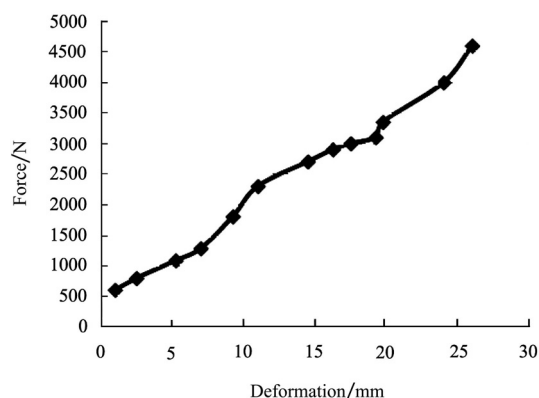

Figure 6 Graph of force-deformation for LDG polythene packaged rice

d) Grain Quality Test: rice samples were packaged in LDG polythene, HDG polythene and woven polypropylene bags which are the conventional packaging materials for rice weights of 25 kg and above. Each packaging material was used in three replications to package 1 kg of rice and left for six months in shelves typical of grain vendor's shelves. With respect to mould growth, discoloration and weevil attack, no difference was noticed by physical examination between the grains stored in the woven polypropylene bags and the polythene bags. However, some of the LDG and HDG packages had small punctured holes which seemed to have resulted from attack by cockroaches.

5 Summary and conclusion

The purpose of the work is to improve the marketability of locally produced rice in Nigeria by enhanced packaging. To this end, a machine for cutting and sealing polythene powered by solar PV and alternatively by grid feed electricity was developed and

tested. Two 55 Watts (peak power), PV modules connected in series and two 60 Ah 12 Volts deep cycle batteries connected in series were found to be adequate for powering the machine. This battery bank size was found to be adequate for a 12-hour per day operation and for three consecutive days of possibly low sunshine. The machine was also found to be able to operate with grid feed electricity of 220 Volts alternating current (ac) conditioned with a step down current transformer of 100 VA. The results showed that Low Density Grade (LDG) polythene and High Density Grade (HDG) polythene could be good packaging materials for small quantities of rice although HDG polythene withstands packaging and transportation hazards better than LDG polythene as indicated by 'fall impact test' and 'compressive test'. However, polythene packaged rice are susceptible to insect (especially cockroaches) attack therefore insect-free selves and environment are recommended for the short time storage of polythene packaged rice awaiting marketing. Further field studies is required to investigate the effect of this kind of packaging on improved marketing of locally produced rice.

[References]

- [1] Brady, G. S., R. H. Clauser, and J. A. Vaccari. 2002. Materials handbook, 15 th edition. McGraw-Hill Company, Inc. New York.
- [2] Brydson, J. A. 1977. Plastics Materials 3rd Edition. London, Newness-Butterworth.
- [3] Daramola, B. 2005. Government policies and competitiveness of Nigerian rice economy. Paper presented at the 'Workshop on Rice Policy & Food Security in Sub-Saharan Africa' organized by WARDA, Cotonou, Republic of Benin accessed online on 15th October, 2009 from, <http://www.warda.org/workshop/RicePolicy/Biyi/Biyi.D.Nigeria.Paper.pdf>
- [4] Kundig, K. J. A. 2002. 'Copper and copper alloys' in Handbook of Material Selection (Ed. Myer Kutz). John Wiley and Sons, Inc., New York.
- [5] Nwajei, O. W. 1998. Design, construction and evaluation of an impulse sealer for making polythene bags for packaging agricultural products- B. Eng. Thesis, University of Nigeria, Nsukka.
- [6] Obi, I. U. 2002. Statistical methods of detecting differences between treatment means and research

- methodology issues in laboratory and field experiment. Department of Crop Science, University of Nigeria, Nsukka. AP Express Publishing Company Ltd.117pp.
- [7] Paine, F. A., and N. Y. Paine (ed.). 1992. A handbook of food packaging, 2nd Edition. Blackie Academic and Professional.
- [8] Raymond, B. S., and E. C. J. Charles. 1982. Polymer chemistry- An introduction, 3rd Edition. New York, Morced Deller Inc.
- [9] Steven, J. S., and G. S. William. 1991. The solar electric house, 2nd edition, Sustainability Press, Still River, Massachusetts.