

Effect of Total Solids Concentration of Municipal Solid Waste on the Biogas Produced in an Anaerobic Continuous Digester

A. Hilkih Igoni¹, M. F. N. Abowei², M. J. Ayotamuno^{1*} and C. L. Eze³

¹Department of Agricultural and Environmental Engineering, Rivers State University of Science and Technology, P.M.B. 5080, Port Harcourt, Nigeria

²Department of Chemical and Petro-Chemical Engineering, Rivers State University of Science and Technology, P.M.B. 5080, Port Harcourt, Nigeria

³Institute of Geo-Sciences and Space Technology, Rivers State University of Science and Technology, P.M.B. 5080, Port Harcourt, Nigeria.

*Corresponding author. E-mail: mjayotamuno@hotmail.com

ABSTRACT

Municipal Solid Waste (MSW) contains a relatively large amount of organic matter, which decomposes by the actions of microorganisms under anaerobic conditions to produce biogas. The total solids (TS) concentration of the waste influences the pH, temperature and effectiveness of the microorganisms in the decomposition process. This work investigated various concentrations of the TS of MSW in an anaerobic continuously stirred tank reactor (CSTR) and the corresponding amounts of biogas produced, in order to determine conditions for optimum gas production. Five laboratory-scale anaerobic batch digesters of 5 litres volume each were set up for the digestion of 2kg of shredded MSW diluted to a %TS concentration of 26.7%. The results from the batch experimentation were adapted to the design of a CSTR for the digestion of MSW. The CSTR was simulated over a range of %TS concentration of 4-10, at a maximum fractional conversion of 0.8 to cater for system inefficiencies. Mathematical models were developed for the process and solved using the Microsoft Visual Basic version 6.0 Programme. The results show the amount of biogas produced as a power function of the %TS concentration, indicating that as the process continues, a time comes when any marginal increase in the %TS concentration would no longer contribute to the increasing volume of biogas produced. The results further show that, given the limiting upper boundary of the %TS concentration, optimum biogas production in a CSTR digesting MSW cannot be ascertained with the concentration of the %TS alone.

Keywords: Total solids, municipal solid waste, biogas, anaerobic digestion, continuous reactor, Nigeria.

Nomenclature/Abbreviation

ρ_m	-	density of methane, kg/m ³
A	-	interfacial gas transfer area, m ²
C_g	-	concentration of methane gas in gas collector, mole/l
C_m	-	concentration of dissolved methane gas, mole/l
COD	-	chemical oxygen demand
C_{st}	-	saturation concentration of methane gas in the liquid, mole/l

A.H. Igoni, M.F.N. Abowei, M.J. Ayotamuno and C.L. Eze. "Effect of Total Solids Concentration of Municipal Solid Waste on the Biogas produced in an Anaerobic Continuous Digester". *Agricultural Engineering International: the CIGR Ejournal*. Manuscript EE 07 010. Vol. X. September, 2008.

DW	-	daily waste load, kg
ITS	-	initial total solids, kg
K_1	-	coefficient of diffusion
M	-	COD conversion factor
M_{mc}	-	mass of methane in continuous digester, kg
PMC	-	percentage moisture content, %
PTDW	-	percentage total solids of daily waste load, %
PTS	-	percentage total solids, %
RTS	-	remaining total solids, kg
S_e	-	effluent substrate concentration, mg/l
S_o	-	influent substrate concentration, mg/l
t_{dc}	-	time of digestion, days
TDW	-	total daily waste load, kg
TS	-	total solids, kg
V_{dc}	-	volume of continuous digester, m^3
V_{gc}	-	volume of gas collector, m^3
V_1	-	volume of liquid in CSTR, m^3
V_{mpc}	-	volume of methane per unit volume of digester, m^3/m^3
V_{mc}	-	volume of methane in continuous digester, m^3
VS	-	volatile solids, kg
V_{tc}	-	total volume of biogas in continuous digester, m^3
X_e	-	effluent microbial concentration, mg/l

1. INTRODUCTION

1.1 Overview of Municipal Solid Waste

Municipal solid waste (MSW) is largely composed of solids that are regarded as useless or unwanted, generated from commercial and domestic units of urban centres (Byrne, 1997; Bailie et al, 1997 and Kiely, 1998). It is a non-fluid type of waste and this makes its handling and management relatively difficult, compared to the types of waste that can flow from one location to the other, or even vaporize (Ogunbiyi, 2001). Thus Kiely (1998) states that solid wastes are those wastes from human and animal activities including liquid wastes like paints, old medicines, spent oils etc.; and MSW contains large amounts of organic matter.

1.2 The Concept of Biogas Production

The decomposition of organic wastes under anaerobic conditions ultimately yields biogas as one of the by-products of the process. Fig. 1 shows the end products of organic decay.

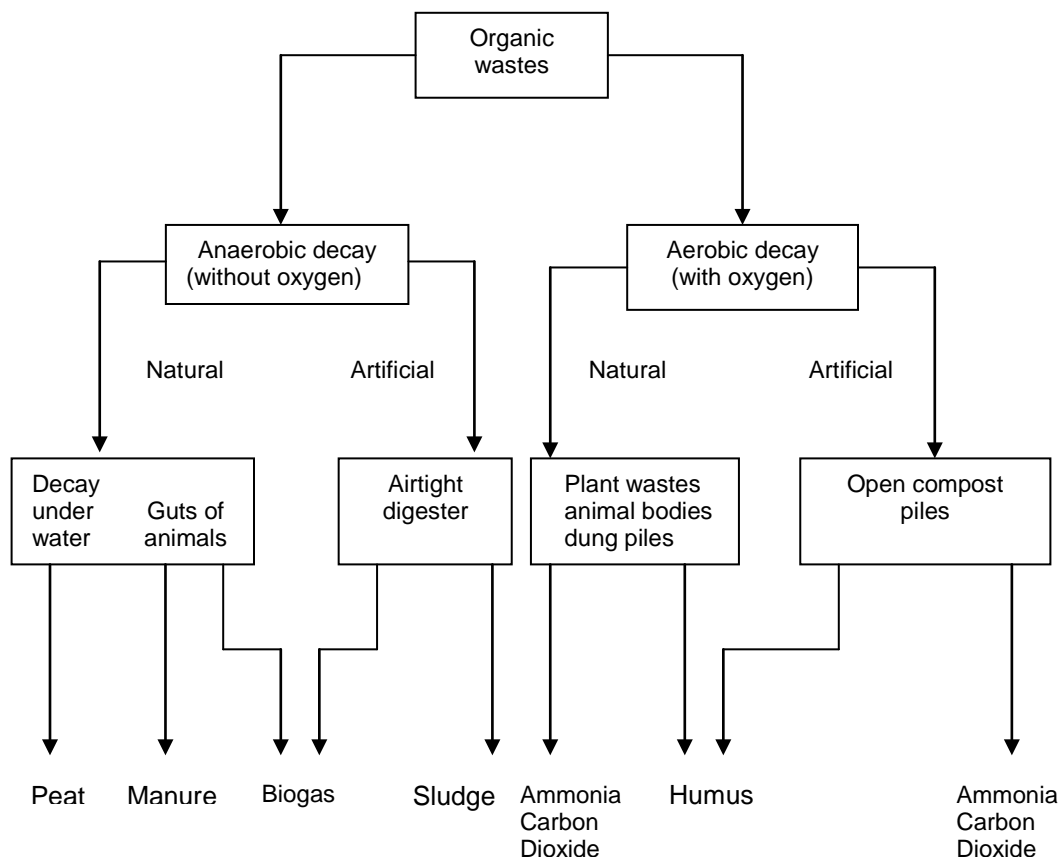

Figure 1. End products of organic decay
(Adapted from Steadman, 1975)

It indicates that biogas could be produced naturally from decay under water or the guts of animal, or artificially in an air tight digester. As a result, biogas has been described as “a methane-rich gas that is produced from the anaerobic digestion of organic materials in a digester” (Itodo and Philips, 2007); and GEMET (2000) says biogas is “gas rich in methane, which is produced by the fermentation of animal dung, human sewage or crop residues in an air-tight container”.

Notably the decomposition of organic matter in the absence of air could be elicited by the use of physical or chemical processes at high temperature and/or pressure, or the use of microorganisms at low temperature and atmospheric pressure, the preferred method being dependent on their relative polluting impacts on the environment. However, despite the method used, gas is produced, but is referred to as biogas if generated as a result of the action of microorganisms on the organic wastes (Hobson et al, 1981). This is why biogas is now defined as “a by-product of the biological breakdown, under oxygen-free conditions of organic wastes such as plants, crop residues, wood and bark residues, and human and animal manure, --- and is known by such other

names as swamp gas, marsh gas, ‘will o’ the wisp’ and Gobar gas” (Mattocks, 1984); and as deep green energy (Seedtree, 2003), and digestion gas (Oregon State Department of Energy, OSDE, 2002), and natural gas (Harris, 2003), and landfill gas (LFG) & sewage gas (Xuereb, 1997).

Biogas is a colourless, relatively odourless and inflammable gas, with the composition shown in Table 1 (adapted from Madu and Sodeinde, 2001).

Table 1. Composition of Biogas

Constituents	% Composition
Methane (CH ₄)	55 – 75%
Carbon dioxide (CO ₂)	30 – 45%
Hydrogen sulphide (H ₂ S)	1 – 2%
Nitrogen (N ₂)	0 – 1%
Hydrogen (H ₂)	0 – 1%
Carbon monoxide (CO)	Traces
Oxygen (O ₂)	Traces

They explain that biogas burns with a blue flame and has a heat value of 4500 – 5000 kcal/m² when its methane content is in the range of 60 – 70%. It is also stable and non-toxic.

1.3 Energy Potential of Municipal Solid Waste

Waste-to-Energy transformation has been identified as a veritable option in the integrated waste management processing of MSW. Vassiliou (1997) explained the "use of state-of-the-art technology to produce biogas, electricity, and organic fertilizer from organic waste - initially from livestock farm waste (various manure, slurry and waste waters) and agro-industrial waste (abattoirs, wineries, vegetable processing plants, etc.); and, in due course, from source-separated MSW.

This is because in the composition of MSW, Byrne (1997) says “organic waste, ranging from garden wastes to food scraps is still the main component”. Also the report of the Urban Development Bank of Nigeria Plc; (Oyinlola, 2001), shows that the organic components account for about 76% of total MSW in Nigeria. In a study of the effect of household size, income level and food consumption pattern on solid waste generation in Enugu urban of Nigeria, Oluka (2001) found that the organic component of the waste is about 91.67% of total MSW. In Igoni (2006) it was found that MSW in Port Harcourt metropolis contains 66.7% of organic matter. Understandably, therefore, the OSDE (2002) stated “municipal solid waste contains a large volume of biomass”; where “biomass resources are any plant or derived organic matter available on a renewable basis”. This includes agricultural and forestry crops, and animal and municipal wastes. Biomass resources can also be burned for heat, produce electricity, or converted to liquid or gas fuels.

In adapting the best environmentally practicable option (BEPO) in solid waste management, the recycling and re-use potential of MSW becomes relevant. This engenders the possibility of converting or transforming MSW into a form that will reduce its volume and especially generate useful by-products in the process. This corroborates the view of Cipolla (1962) in Hughes (1976) when he states that “the more successfully man can use his own energy output to control and put to use other forms of energy, the more he acquires control over his environment and achieves goals other than those strictly related to animal existence”.

1.4 Anaerobic Continuous Digestion

Mahnert et al (2005) noted that the wide spread introduction of anaerobic digestion in Germany (and indeed many countries) has shown that biogenic organic wastes are a valuable source for energy and nutrients. One system in common use for anaerobic digestion is the continuously stirred tank reactor (CSTR). Usually because of the thorough mixing in the CSTR, the contents are assumed uniform in concentration with no concentration gradients, hence equal to the effluent concentration. In addition, the flow regime of materials in a CSTR predisposes it to the digestion of low-solids materials. Tchobanoglous et al, 1993, define low-solids anaerobic digestion as “a biological process in which organic wastes are fermented at solids concentrations equal to or less than 4 to 8 percent”. Despite this characteristic, they say the CSTR ‘has also been employed to generate methane from human, animal and agricultural waste, and from the organic fraction of municipal solid waste”.

OSDE (2002) says, “a complete mix digester is suitable for manure that is 2 percent to 10 percent solids”; and Steadman (1975) says, “the recommended percentage of solids in the digesting mixture is between 7% and 9%”. Because MSW is characteristically a high solid and high volume waste, and the CSTR, although suited for high volume waste, is essentially for low total solids concentration, it is therefore necessary to ascertain the nature of interaction between the total solids concentration of the waste and the performance of the digester.

Therefore, this study investigated the performance of the CSTR digesting MSW, in terms of the amount of biogas produced, as a function of the percentage total solids concentration of the waste.

2. MATERIALS AND METHODS

2.1 Reactor Experimentation

Five laboratory-scale anaerobic batch digesters each of 5 litres volume were set up for this experiment. Hobson *et al* (1981), say “with a batch digester a smaller experimental system may be suitable as the digester has only to be loaded once and may not even need to be stirred. One or two litres could be big enough”. The schematic of the experimental design layout is as shown in figure 2.

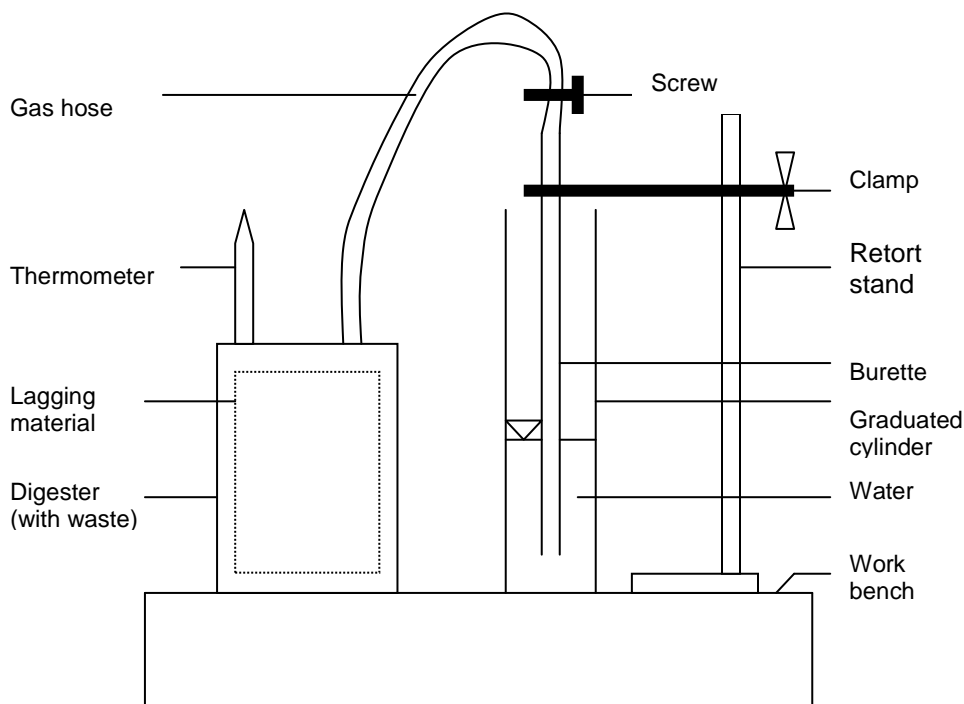

Figure 2. Schematic of reactor experimentation design layout

The anaerobic digesters were actually improvised with large cans, which were properly lagged with wool material of about 25mm thickness, to minimize as much as possible the interaction between the temperatures inside and outside of the digesters. Two perforations were made on the cover of the digester through which the gas hose and thermometer were fitted. The hose extending from the digester top was connected to the tail of a burette, which in turn was then partly immersed in water in a graduated cylinder.

The waste materials were processed (shredded and mashed), and the digesters were then loaded with 2kg of organic MSW, which was diluted to a 26.7% total solids (TS) concentration.

The pH was measured from a digital pH meter, and the substrate and biomass concentrations, were respectively determined in terms of the chemical oxygen demand (COD), and the mixed liquor volatile suspended solids (MLVSS). From an ultimate analysis the carbon, (C) and nitrogen (N) content were known from which the C: N ratio was computed. While the Carbon was determined using the Walkey-Black method, the Nitrogen was determined with the usual macro-kjedahl method.

The thermometer, which passed into the headspace of the digester, was used to measure the temperature inside the digester; and the ambient temperature was measured from maximum and minimum thermometers at the same time. These temperature measurements were taken at 0800 hours and 1400 hours, and aimed at determining temperature variation within and outside the digester, in order that proper digester insulation considering also construction materials is determined.

After these initial measurements from the waste replications, the digesters were then made airtight with glue and other adhesives, and the set-up allowed to run. Each of the digesters was dismantled at intervals of 5 days, which gave the experimentation a total lifespan of 25 days. At each dismantling, substrate (COD) and microbial (MLVSS) concentration measurements were repeated; and the predominant microorganism was noted.

The experimental results obtained were used to generate data for the design of a CSTR using the method prescribed by Bailie and Ollis (1986), and adopted by Igoni (2006). The operation of the CSTR was then simulated over a range of percentage total solids concentration of 4 – 10, at a fixed fractional conversion of 0.8, using a Microsoft visual basic version 6.0 computer programme, which was developed for the purpose.

The following relationships were used as part of the simulation programme.

$$PMC = 100 - PTS$$

where PMC - Percentage moisture content

$$PTDW = 0.801 \times TDW$$

PTDW - Percentage total solids of daily waste load

$$ITS = TDW \times \frac{PTS}{100}$$

$$RTS = PTDW - ITS$$

RTS - Remaining total solids

Total organic waste load is calculated as, $DW = TDW \times RTS$

and total solids concentration is determined from: $TS = DW \times \frac{PTS}{100}$

After the design of the digester, the concentration of the methane gas in the gas collector was calculated from the following relationships:

Actual concentration of dissolved methane gas, $C_m = 0.296 \times M \times (S_o - S_e)$

Concentration of methane gas in gas collector, $C_g = \left(K_l \times \frac{A}{V_l}\right) \times (C_{st} \times C_m) \times t_d$

Volume of gas collector, $V_{gc} = \frac{1}{3} \times V_{dc}$

Mass of methane gas, $M_{mc} = C_g \times V_{gc}$

Volume of methane, $V_{mc} = \frac{M_{mc}}{\rho_m}$

$$\text{Total volume of biogas, } V_{tc} = 100 \times \frac{V_{mc}}{60}$$

3. RESULTS AND DISCUSSION

The results of the simulation establishing the volume of biogas (in cubic meters) corresponding to the varying total solids (TS) concentration of the municipal solid waste, from 4% to 10% are presented in Table 2. The upper boundary of the experimental range for the TS concentration appears limited, but this is attributable to the maximum amount of total solids concentration the highest capacity pump can handle (Hobson et al, 1981). However, this is also the region of active performance of microorganisms decomposing the waste, because of the sufficient availability of liquid content in that range.

Table 2. Reactor parameters for various percentage total solids concentrations

PTS (%)	TS (kg)	VS (kg)	S _e (mg/l)	X _e (mg/l)	t _{dc} (days)	V _{dc} (m ³)	V _{mc} (m ³)	V _{tc} (m ³)	V _{mpc} (m ³ /m ³)
4	9971.44	6640.98	0.381	0.2604	8.40	66.98	6.29	10.48	0.0939
6	16208.81	10795.07	0.861	0.5479	8.16	105.81	18.88	31.46	0.1784
8	23280.61	15504.89	1.536	0.9527	8.07	150.28	42.22	70.36	0.2809
10	31186.84	20770.43	2.410	1.4765	8.03	200.22	79.86	133.10	0.3989

The relationship between the volume of biogas produced and the percentage total solids concentration was analysed using the Microsoft chart editor. It was found that the volume of biogas produced is a power function of the percentage total solids concentration, thus:

$$V_{tc} = 0.2225 \times \text{PTS}^{2.7717}$$

This conforms to the power relationship between the volume of biogas and percentage total solids concentration already established for the batch digester processing MSW (Igoni et al, 2007). As in the case of the batch system, this relationship also shows that a marginal increase in the PTS results in a geometric increase in the volume of biogas produced, suggesting therefore (as also evident from Figure 2) that a continual increase in the PTS at some point becomes immaterial to the increasing volume of biogas produced. This is possible because when PTS increases, the amount of water decreases, thus reducing the level of microbial activity, which then affects the amount of biogas, particularly at higher values of the PTS. Again, Itodo and Awulu (1999) showed that slurries of higher TS concentrations were more acidic than that of lower TS concentrations, which is an additional reason why higher PTS values would not significantly affect the increasing volume of biogas produced. Although the simulation in this work had considered a constant pH value (Igoni, 2006), which would not be the case in practical digestion, it is noteworthy however that the effect of an increasing pH would rather justify the findings of this work, since it would ultimately fix a limit to the required level of PTS.

Unfortunately, the upper limit of the CSTR TS capacity restrains investigation beyond the 10% TS concentration, thus leading to the deduction that the determination of optimum biogas production from a high solids substrate like MSW in a CSTR using the percentage total solid concentration alone may be misleading.

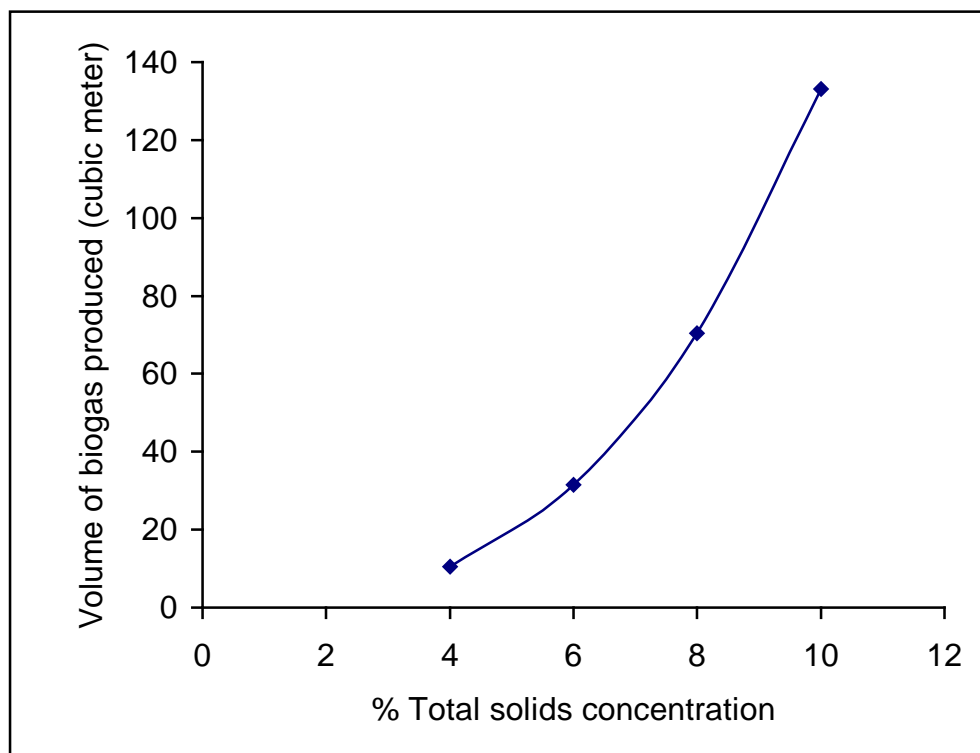

Figure 2. Variation of volume of biogas generated in a CSTR with percentage total solids concentration

4. CONCLUSION

When the percentage total solids (PTS) of municipal solid waste in an anaerobic continuous digestion process increases, there is a corresponding geometric increase for biogas produced. A statistical analysis of the relationship between the volume of biogas produced and the percentage total solids concentration established that the former is a power function of the latter, indicating that at some point in the increase of the PTS, no further rise in the volume of the biogas would be obtained. However, the upper boundary limit of the continuous process imposed by the highest available pump capacity restrained the investigation from establishing that point. It shows that it will be difficult to establish optimum biogas production from CSTR using MSW, with the PTS concentration alone. Notably, in all these processes, appropriate steps must be taken to control the pH of the system, which must be between 7.0 and 7.2 for highest gas production (Stout, 1983, in Itodo and Awulu, 1999).

5. REFERENCES

- Bailey, J. E. and D.F. Ollis, 1986. *Biochemical Engineering Fundamentals*. New York: McGraw-Hill Book Publishers. 753pp.
- Bailie, R. C., J. W. Everett, B. G. Liptak, , D. H. F. Liu, F. M. Rugg and M. S. Switzenbaum. 1996. Solid Waste. In *Environmental Engineers Handbook*, eds. D. H. F. Liu, B. G. Liptak, and P. A. Bouis, pp 1148 – 1248. New York: Lewis Publishers.
- Byrne K. 1997. *Environmental Science*. United Kingdom: Thomas Nelson & Sons Ltd. 206 pp.
- General Environmental Multilingual Thesaurus (GEMET). 2000 [Online]. Available: <http://glossary.eea.eu.int/eeaglossary/b/biogas>
- Harris, P. 2003. *Beginners Guide to Biogas* [Online]. Available: <http://www.ees.adelaide.edu.au/pharis/biogas/beginners/html>
- Hobson, P. N., S. Bousfield and R. Summers. 1981. *Methane Production from Agricultural and Domestic Waste*. London: Applied Science Publishers Ltd. 269 pp.
- Hughes, W. L. 1976. Energy for Rural Development – Renewable resources and alternative technologies for developing countries”, (Edited) *Report Submitted to National Academy of Sciences*, Washington. 307pp.
- Igoni, A. H. 2006. Design of anaerobic bio-reactors for the simulation of biogas production from municipal solid waste. Ph.D Thesis, Rivers State University of Science and Technology, Port Harcourt, Nigeria.
- Igoni, A. H., M. F. N. Abowei, J. M. Ayotamuno, and C. L. Eze. 2007. Effect of total solids concentration of municipal solid waste in anaerobic batch digestion on the biogas produced. *Journal of Food, Agriculture & Environment* 5 (2): 333 – 337.
- Itodo, I. N. and J. O. Awulu. 1999. Effects of total solids concentrations of poultry, cattle, and piggery waste slurries on biogas yield. *Transactions of the ASAE* 42(6): 1853 – 1855.
- Itodo, I. N and T. K. Phillips. 2007. Nomograph for determining temperatures in anaerobic digesters from ambient temperatures in the tropics. *Agricultural Engineering International: the CIGR Ejournal* Vol. IX, Manuscript EE 06 010.
- Kiely, G. 1998. *Environmental Engineering*. International Edition. Boston: Irwin Mcgraw-Hill. 979 pp.
- Madu, C. and O. A. Sodeinde. 2001. Relevance of biomass in the sustainable energy development in Nigeria. In *Proc. National Engineering Conference and Annual General Meeting of the Nigerian Society of Engineers*, 220 - 227.
- Mahnert, P., M. Heiermann and B. Linke. 2005. Batch- and semi-continuous biogas production from different grass species. *Agricultural Engineering International: the CIGR Ejournal* Vol. VII, Manuscript EE 05 010.
- Mattocks, R. 1984. Understanding biogas generation. Technical Paper No. 4. Virginia, USA: *Volunteer in Technical Assistance*. 13 pp.
- Ogunbiyi, A. 2001. Local technology in solid waste management in Nigeria. In *Proc. National Engineering Conference and Annual General Meeting of the Nigeria Society of Engineers*, 73-79.
- Oluka, S. I. 2001. Effects of household size, income level, and food consumption pattern on solid waste generation in Enugu urban of Nigeria. In *Proc 2nd International Conference and*

A.H. Igoni, M.F.N. Abowei, M.J. Ayotamuno and C.L. Eze. “Effect of Total Solids Concentration of Municipal Solid Waste on the Biogas produced in an Anaerobic Continuous Digester”. *Agricultural Engineering International: the CIGR Ejournal*. Manuscript EE 07 010. Vol. X. September, 2008.

- 23rd Annual General Meeting of the Nigerian Institution of Agricultural Engineers, 367-373.
- Oregon State Department of Energy (OSDE). 2002. Biomass energy technology [Online]. Available: <http://www.oregondoe.org>
- Oyinlola, A. K. 2001. Recycling/Resource recovery technology option for a sustainable solid waste management system in Nigeria. In *Proc. National Engineering Conference and Annual General Meeting of the Nigerian Society of Engineers*, 63-72.
- Seedtree Biogas Program. 2003. Biogas [Online]. Available: <http://www.Seedtree.org/biogas.html>.
- Sincero, A. P. and , G. A. Sincero. 1999. *Environmental Engineering – A Design Approach*. New Delhi: Prentice-Hall of India Private Limited. 795pp.
- Steadman, P. 1975. *Energy, Environment and Building*, A Report to the Academy of Natural Sciences of Philadelphia. Cambridge: Cambridge University Press. 287 pp.
- Stout, B. A. 1983. Biomass Energy Profiles. *Agricultural Service Bulletin*, No. 54. Rome, Italy: Food and Agricultural Organization.
- Tchobanoglous, G, H. Theisen and S. Vigil. 1993. *Integrated Solid Waste Management: Engineering Principles and Management Issues*. New York: McGraw-Hill Inc.. 978pp.
- Vassiliou, N. 1997. The Biogas Project of Cyprus. *1st International Conference of Energy and the Environment*, 757-761. Limassol, Cyprus.
- Xureb, P. Biogas [Online]. Available: <http://www.synapse.net.mt/mirin/newsletter/3836.asp>