

Battery-operated upland weeder: An economically viable and environmentally friendly weed management approach for sustainable crop production

Md Ashrafuzzaman Gulandaz* , Muhammad Arshadul Hoque, Md Nurul Amin

(Farm Power Machinery and Post-Harvest Division, Bangladesh Agricultural Research Institute, Joydebpur, Gazipur, 1701, Bangladesh)

Abstract: The goal of this work was to reduce the production cost and drudgery of labor for weeding purposes and use renewable energy for upland crop production. Traditional weeding is common and the most widely used weed control method, but it is labor-intensive. Adverse effects on the environment and the cost of chemical weeding are making farmers consider mechanical methods of weed control. Therefore, a battery-operated (BO) weeder was designed and fabricated considering methodological steps. For performance evaluation, field trials were done among the BO weeder, the Bangladesh Agricultural Research Institute (BARI) push and pull weeder, manual weeding, and chemical weeding. The field trials were conducted on maize, chili, and eggplant. The performance of the BO weeder is quite acceptable for wide row crops. The weeding index of the BO weeder for maize, chili, and eggplant was 92.52%, 95.85%, and 92.79%, respectively, which is very close to chemical weeding. Again, effective field capacity, i.e., the area coverage of the BO weeder for maize, chili, and eggplant, was 0.04643, 0.02167, and 0.0463 ha hr⁻¹, respectively. Plant damage ratio was varied and limited for maize, which was only 0.50%, but it grew a little up to 2.8% for chili and eggplant. The cost of weeding by BO weeder was almost half compared to BARI weeder and just about one-third compared to manual weeding but equivalent to chemical weeding. But no significant difference for yield was found among these three methods except for eggplant. We found better yield in eggplant for battery weeders compared to other practices. Therefore, the newly designed and fabricated BO weeder may be used as an economically viable, environmentally friendly, and non-chemical weed management approach for sustainable crop production in the modern era of changing climate.

Keywords: weeder, battery operated, weed management, environmentally friendly, cost-effective

Citation: Gulandaz, M. A., M. A. Hoque, and M. N. Amin. 2026. Battery-operated upland weeder: An economically viable and environmentally friendly weed management approach for sustainable crop production. *Agricultural Engineering International: CIGR Journal*, 28(2): 81-93.

1 Introduction

A weed is considered a plant but one that is growing mistakenly in terms of place and time and doing more harm than good (Argüelles and March 2021). Weeds are plants that compete with crops for water, nutrients, and light. Crop production can be

reduced significantly due to excessive weeds. The weeds should be managed at their early stage of plant, i.e., 15 to 20 days after sowing. Depending upon the weed density, 20% to 30% loss in yield is quite usual, but for inadequate crop management, yield loss climbs up to 80% (Merfield, 2022). Weeds cause an unexpected loss of farmers' time, which makes an

Received date: 2025-05-04 **Accepted date:** 2025-08-15

*Corresponding author: **Md Ashrafuzzaman Gulandaz**. Farm Power Machinery and Post-Harvest Division, Bangladesh Agricultural Research Institute, Joydebpur, Gazipur, Bangladesh. Email: gulandazfmpe.bari@gmail.com.

obstacle to development (Jayaseelan et al., 2020). One of the most difficult tasks is controlling weeds in agriculture, which marks a considerable stake of the cost involved in agricultural production (Rao et al., 2020). Farmers commonly are very concerned about effective weed control measures to seize the growth and propagation of weeds.

Weeds are an immense problem for Kharif crops (Lavanya et al., 2021). The high cost of weeding can be understood from a comparative study of the losses in the farm due to various causes (Horvath et al., 2023). Under plant protection, weed control plays an important role in increasing the yield (Liu et al., 2023). According to the International Rice Research Institute (IRRI), the yield loss in transplanted and direct-seeded rice due to weeds alone was assessed as 34% and 45%, respectively (Singh et al., 2008). The research result of Bangladesh Agricultural Research Institute (BARI) showed that weeds can affect 80% for eggplant production, 43% for potato production, and 22% for maize production (BARI, 2020). Reduction of the yield becomes more severe when a weed acts as a harbor for insects (Hussain et al., 2021). The losses due to weeds outstrip the losses caused by any other category of agricultural pests (Baker et al., 2020). Of the total annual loss in agricultural produce, weeds account for 34%, insects and pests 26%, salinity 13%, anthropogenic factors 14%, global warming 17%, and disease 20% (Junaid and Gökçe, 2024). But in SRI (System of Rice Intensification), weeds are seen as growth promoters when they are appropriately managed (Deb, 2020).

The weeder is reducing the drudgery and ensuring a comfortable posture for the farmer or operator during weeding, which increases production (Burman et al., 2020). Mechanical weeding keeps the soil surface loose for ensuring soil aeration and water intake capacity (Woyessa, 2022). Rotary operation on the soil surface will always bring the best result (Varani and Mattetti, 2023). The rotary weeder can operate at various working depths, widths, and soil conditions (Mandal et al., 2013). The rotating blades chop and

mix the residues evenly throughout the working depth, outperforming any other mechanism (Yang et al., 2023). Nowadays, the chemical method of weed control is more prominent than manual and mechanical methods (Woyessa, 2022). However, negative impacts on the environment are making farmers consider and accept mechanical methods of weed control. Manual weeding is a very common practice in Bangladeshi agriculture (Paul et al., 2025). Though labor-intensive, it is the most widely used weed control method (Woyessa, 2022). Agricultural labor is becoming scarce day by day in Bangladesh (Quddus and Kropp, 2020). The costs associated with mechanical weeding, such as operating costs, can be lowered, and mechanical weeding can represent a sustainable and cost-effective option for the majority of medium and small-scale farmers in developing countries like Bangladesh (Ahmed et al., 2021).

The main objective of this research is to develop a battery-operated (BO) weeder that can be used in wide row crops, plant spacing systems, various plant intra-row distances, and growth stages, offering an eco-friendly alternative to chemical weed control and fossil fuel-powered weeders. This weeder reduces weeding time, lowers costs, and increases productivity by improving labor efficiency.

2 Materials and methods

2.1 Assumptions

Design of the rotary weeder depends on field conditions, crop and soil types and energy requirement of the machine. The machine is powered by a 48-volt 750-watt motor which is operated by 48-volt rechargeable dry cell battery. A belt and sprocket arrangement is used for transmission of power. Motor speed is 700 rpm; the number of teeth on sprocket is 15, and the number of teeth on sprocket of rotary shaft is $15 \times 2 = 30$; the rotary shaft speed is 350 rpm; the maximum value of soil resistance is 103 kPa; the coefficient of friction is 0.1, and the efficiency of transmission system is 90%.

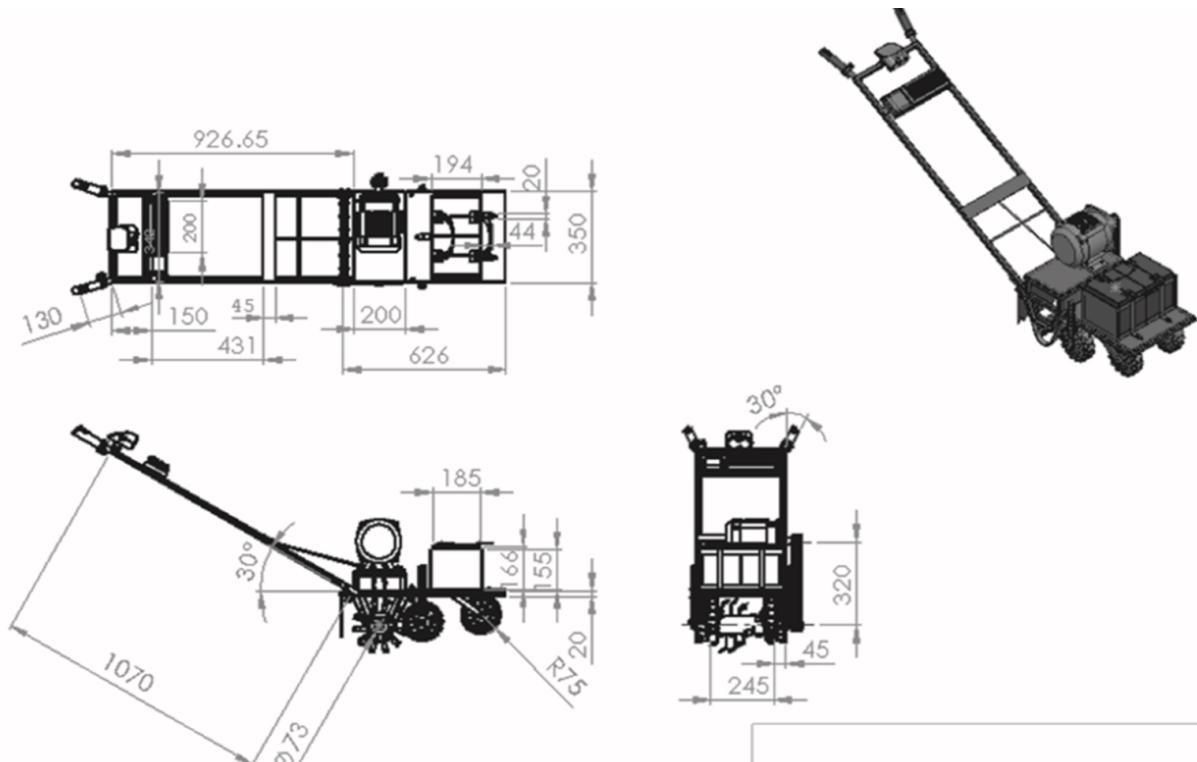

Figure 1 BO weeder with dimension

2.2. Design Process

The power requirement of motor, the chain and sprocket selection, and the design and arrangement of tines must be considered in the design process. There is no power in the wheel; therefore, the weeder should be pushed manually, but the continuous pushing of tines makes weeder go forward easily. The power supply on the rotary shaft should be taken into

consideration. There are two parts of the weeder, one is the body and another is the handle. The body part consists of the motor, battery, wheel, and rotary shaft, while the handle consists of an auto switch and converter. Figure 1 represents the drawing of weeder with dimension and Figure 2 represents the 3D drawing of weeder.

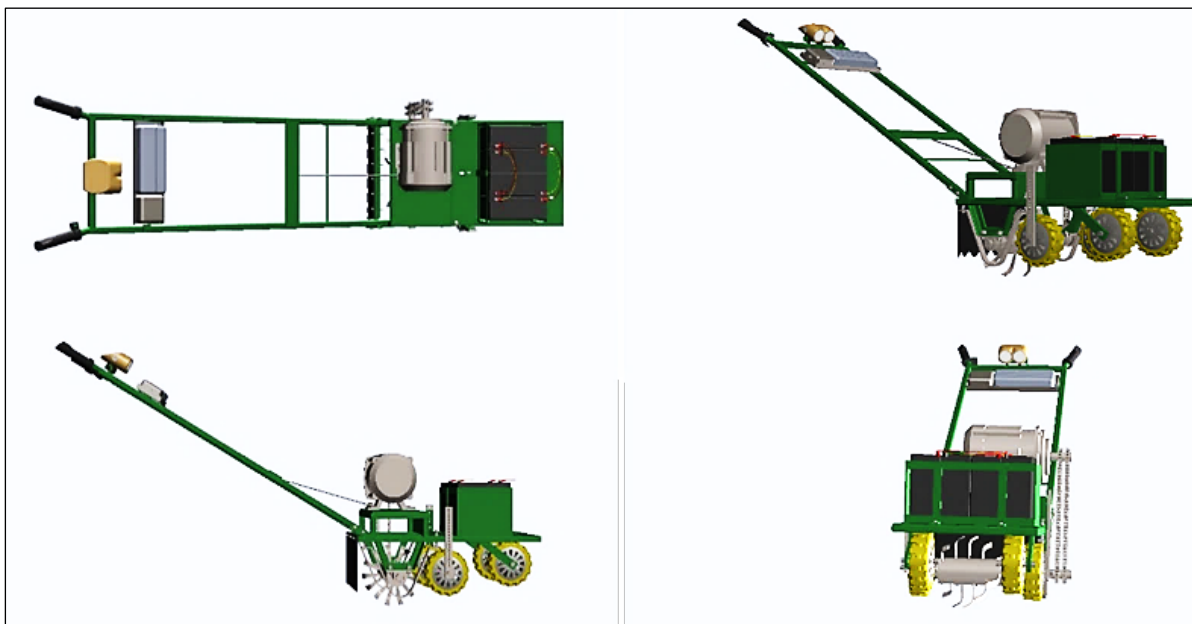

Figure 2 Top, isometric, side, and front views of BO weeder

2.3 Power requirements

The following equations are used for calculating

the power requirement (Hunt, 1983):

$$P_d = \frac{S r \times d \times w \times v}{75} (h_p) \tag{1}$$

Where,

S_r = soil resistance, kgf cm^{-2} ;

d = depth of cut = 2.5 cm;

w = effective width of cut = 26 cm;

v = linear velocity of the tine at the point of contact with the soil = 1 cm s^{-1} ;

Hence, power requirement is estimated as

$$P_d = \frac{S_r \times d \times w \times v}{75} = \frac{1.05 \times 2.5 \times 26 \times 1}{75} = 0.91$$

Total power required:

The total power required is estimated as 1.89 hp as follows:

$$P_t = \frac{P_d}{\eta} = 1.01 = 1 \text{ hp}$$

Where,

P_d = Power required to dig the soil;

η = Transmission efficiency (0.90).

Thus, a prime mover of 0.735 kW was required for this weeder.

2.3 Chain and sprocket selection:

Chain and sprocket arrangement were adopted for transmission of power. The chain, sprocket, and shaft selection were based on agricultural machinery management data. The size of the chain is 60B, and the number of teeth of the sprocket is 14. The chain, sprocket, and shaft are shown in Figure 3.



Figure 3 Chain and sprocket for BO weeder

2.3 Weeding tines and tine Arrangement

A J-shaped tine is designed on the shaft, which is shown in Figure 4. The length and width of the tine are 80 mm, the curve angle of tine is 120° and 18 mm respectively (Figure 5). The dimensions of the shaft are 245 mm and 73 mm, respectively. The shaft consists of tines of equal lengths arranged in a spiral shape determined as follows (Figure 5).

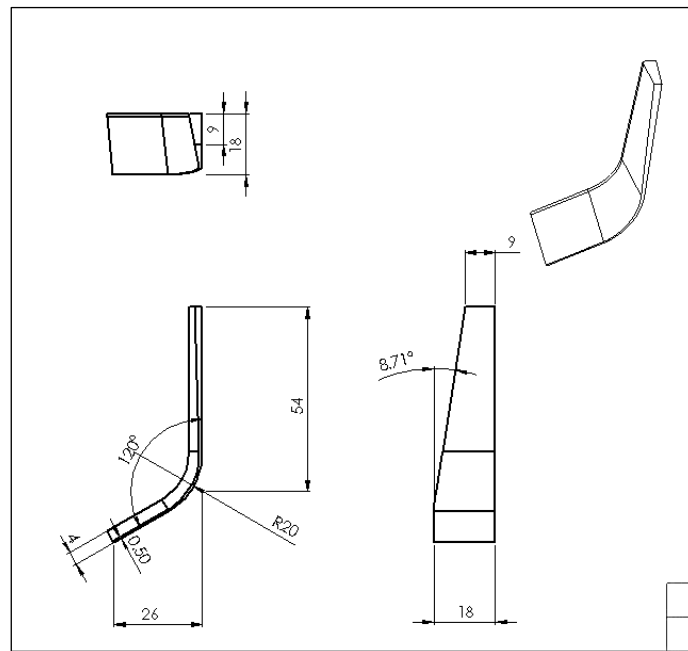

Figure 4 J-shaped tine for BO weeder

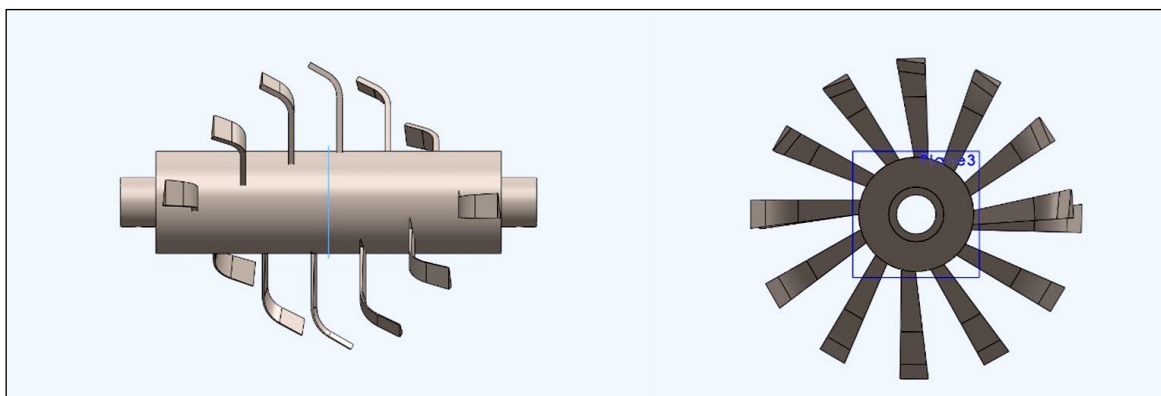

Figure 5 Spiral arrangement of J-shaped tine for BO weeder

2.4 Machine description

The power to the rotary hoe is supplied from the motor through a chain and sprocket. Most of the components of the weeder were fabricated at the Farm Machinery and Post-Harvest Process Engineering (FMPE) Division, Bangladesh Agricultural Research

Institute (BARI) (23.9912664, 90.4178956). Standard components, such as motor and transmission elements, were picked up locally, and the parts were assembled at the same workshop. The pictorial view of the rotary weeder was shown as Figure 6. The specifications of the BO weeder are shown in Table 1.

Table 1 Specification of BO weeder

Sl no	Items		Measurement
1	Power	Motor	1 hp (750 watt)
		Battery	48-volt Dry cell rechargeable Battery
2	Dimension (with Rotary Tine)		1560 mm x 350 mm
3	Weeder Forward Speed		2 km h ⁻¹
4	Rated Motor Speed		700 rpm
5	Rated Rotary Speed		350 rpm
6	Rotary Shaft	Length	245 mm
		Diameter of Shaft	73 mm
7	Tine	Number of Tine	14
		Type of Tine	J-shaped
		Tine Arrangement	Spiral
		Width of tine	18 mm
8	Diameter of wheel	Length of tine	75 mm
			160 mm
9	Starting System		Auto switch
10	Net Weight		kg



Figure 6 Pictorial view of BO weeder

2.4 Performance test and evaluation

2.4.1 Laboratory test

The laboratory test results are summarized in Table 2.

2.4.2 Site and experimental condition

The experiment was conducted at the FMPE division research field of Bangladesh Agricultural Research Institute (BARI) (23.9912664, 90.4178956)

during the Kharif season of 2018-19. The soil was clay loam, and soil penetration was recorded before each

treatment was imposed. The experiment plot was well pulverized and leveled with a tractor.

Table 2 Laboratory test results

Parameter	Average value
Rated motor speed, rpm	580
Rotary blade speed, rpm	500
Theoretical field capacity, ha h ⁻¹	0.05

2.4.3 Crop and weeds

2.4.3.1 Maize

Hybrid maize (elite) was planted manually in the experimental plot (6.5 x 7 m each) with 60 cm row-to-row spacing and 25 cm plant-to-plant spacing. Each plot accommodated 6 rows. The date of the planting was 14th December 2018. The density of weed was recorded before and after treatment was imposed. The weed sampling was done randomly in the middle three rows in 1.2 x 1 m quadrants. The width of the cut is 20 cm, so three passes are done to cover 60 cm of width. The amount of plant damage is recorded, and interplant weeds were removed by mechanical methods.

2.4.3.2 Chili

BARI chili-1 was planted manually in the experimental plot (4 x 2 m each) with 50 cm row-to-row spacing and 50 cm plant-to-plant spacing. Each plot accommodated 4 rows. The date of the planting was 20th December 2018. The density of weed was recorded before and after treatment was imposed. The weed sampling was done randomly in the middle three

rows in 1.2 x 1 m quadrants. The width of the cut is 20 cm, so three passes are done to cover the 50 cm width. The number of plant damage is recorded, and interplant weeds were removed by mechanical methods.

2.4.3.3 Eggplant

BARI BT Begun-4 was planted manually in the experimental plot (5 x 4 m each) with 100 cm row-to-row spacing and 75 cm plant-to-plant spacing. Each plot accommodated 4 rows. The planting date was 17th December 2018. The density of weed was recorded before and after treatment was imposed. The weed sampling was done randomly in the middle three rows in 1.2 x 1 m quadrants. The width of the cut is 20 cm, so three passes are done to cover 60 cm of width. The number of plant damage is recorded, and interplant weeds were removed by mechanical methods.

The common species of weeds were recorded. The following weeds are significantly present in the testing plots, which are shown in Table 3.

Table 3 Most common weeds in the testing plot

Local Name	Specifications	Comments
Chapra	Eleusine indica L.	
Durba	Cynodon dactylon L.	
Mutha	Cyperus rotundus	First three were dominant
Helencha	Enhydra fluctuans L.	
Paddy seedlings	Oryza sativa	

Table 4 BARI-recommended dose of fertilizer and irrigation

Crops	Nitrogen (N)	Phosphorus (P)	Potassium (K)	Sulfur (S)	Zinc (Zn)	Irrigation
Maize	75	20	40	15	-	5, 25, 50, 75 DAS*
Chili	32	15	25	5	0.5	Maintaining consistent soil moisture over the period
Egg plant	45	12	35	5	-	4 DAT** and during fruit development stage. Maintaining consistent soil moisture over the period

Note: *DAS= Days after sowing, **DAT = Days after transplanting

2.4.3.4 Fertilizer, irrigation, and earthing up

Fertilizer and irrigation were applied as BARI-

recommended doses shown in Table 4. And earthing up for maize is done manually at 45 days after sowing

(DAS).

2.4.4 Experimental design

The study included three treatments replicated four times. The experiment was designed in a randomized complete block. The treatments were T₁—weeding by BARI battery-operated weeder at 15 and 30 DAT; T₂—weeding by BARI push and pull weeder at 15 and 30 DAT; T₃—manual weeding at 15 and 30 DAT; and T₄—chemical weeding by herbicide (Gramoxon-3 ml/liter) spray at 15 and 30 DAT.

2.4.5 Test procedure

The performance of the weeder is examined by the following indicators:

2.4.6 Weeding index

The weeding index is a ratio between the number of weeds removed by a weeder and the number present in a unit area and is expressed as a percentage (Rangasamy et al., 1993). Three randomized selected areas of 1 m x 1 m in each replication were marked out for sampling. Weeds in each plot were counted before and after weeding using the BO rotary weeder. The time taken to perform this operation was noted. Equation 2 (Rangasamy et al., 1993) was used to calculate the weeding index.

$$\text{Weeding Index, } I_w = \frac{w_1 - w_2}{w_1} \quad (2)$$

Where,

W₁ = weeds number before weeding;

W₂ = weeds number after weeding

2.4.7 Plant damage

Plant damage was observed in the mechanical method and recorded. Plants, damaged completely or uprooted, were counted as 'damaged' and expressed as a percent of each plot; the plant damage percent was evaluated by using Equation 3 (Hedayatipour et al., 2021).

Plant Damage percent

$$\Sigma = \frac{w_2}{w_1} \times 100 \quad (3)$$

where,

w₁ = number of Plant before weeding;

w₂ = number of the damaged plant after weeding;

Σ = Plant Damage percent

2.4.8 Field efficiency

The ratio of actual or effective field capacity (EFC) to TFC is called the machine's field efficiency (FE).

$$\text{Field efficiency} = \frac{\text{Effective Field Capacity}}{\text{Theoretical Field capacity}} \times 100 \quad (4)$$

Theoretical Field Capacity: Theoretical field capacity (TFC) depends only on the full operating width of the machine and the average travel speed in the field.

Field capacity: The weeding tools were tested on the same plots to determine the field capacity of each of the practices. Field capacity is the amount of area that a weeding tool can cover per unit time, as shown in Equations 4 and 5 (Hunt, 1983).

$$\text{Field Capacity (ha hr}^{-1}\text{)} = \frac{60}{t} \times \frac{A}{10000} \quad (5)$$

where,

A = Area covered (m²);

t = Time taken in hours

2.5 Cost parameters for economic analysis

2.5.1 Depreciation cost

The ratio between salvage values deducted from the purchase price and the life of a machine.

2.5.2 Benefit-cost ratio (BCR)

It refers to the ratio of gross/total return to the gross cost or total cost. It indicated the amount of taka a farmer receives for every taka he spent.

2.5.3 Payback period

The length of time required to recover the cost of an investment.

2.6 Statistical analysis:

All statistical analyses in this experiment were carried out using the statistical package "R 3.4.4" for Windows Version 2010. Analysis of variance (ANOVA), coefficient of variance (CV%), and least significant difference (LSD) between mean values was calculated at a 5% significance level.

3 Results and discussion

3.1 Experimental factors

Experimental factors used in the field evaluation of the rotary power weeder were approximately equal speeds in three blocks. The motor had the option for operating at low, medium, and high speeds. So, the weeder was operated at medium speed in all the plots.

The weeding performance was compared with the BARI manual weeder and the traditional weeding method. Weeding experiments were conducted in maize, chili, and eggplant at the FMPE division's experimental field.

3.2 Performance evaluation and experimental analysis:

3.2.1 Maize

The performance evaluations were done to investigate the effect of weed density on the performance of four weeding methods, such as battery-operated (BO) weeder (T_1), BARI push and pull weeder (T_2), manual weeding by spade (T_3), and

chemical weeding through weedicide (T_4). Prior to each weeding schedule, weed density in each experimental unit was determined by laying out a squared grid (1 m x 1 m) in the plot and counting weeds in the grid. Four such determinations were made for each experimental unit.

Field capacity, weeding index, plant damage, and grain yield in weeding by BO weeder, BARI push and pull weeder, manual weeding by spade, and chemical weeding methods in maize fields and their coefficient of variance (CV%) as well as least significant difference (LSD) values are shown in Table 5.

Table 5 Field performance of different weeding methods in maize fields

Treatment	Field capacity (ha h ⁻¹)	Weeding index (%)	Plant damage ratio (%)	The yield of maize grain (t ha ⁻¹)
T ₁ (BO weeder)	0.04643 a	92.52 b	0.50 a	8.90 a
T ₂ (BARI weeder)	0.01370 c	86.19 c	0.75 a	8.42 a
T ₃ (Manual weeding)	0.01413 c	93.48 b	0.50 a	8.42 a
T ₄ (Chemical weeding)	0.03920 b	99.22 a	0.00 b	7.91 a
CV (%)	3.8087	1.92	37.82	10.89
LSD (0.05)	0.0033	3.57	0.33	1.83

Table 6 The performance of the BO weeder for maize compared to other weeding practices

Items	Weeding Method			
	BO weeder	BARI weeder	Manual weeding	Chemical Weeding
Row to row distance (cm)	60	60	60	N/A
Number of turns per row	3	4	N/A	N/A
Average Weeding depth (cm)	4.93	1.5	N/A	N/A
Cutting width (mm)	200	150	180	N/A
Average soil penetration (kPa) (10 cm height)	648	648	648	648
Forward speed (km h ⁻¹)	2.5	2	1.5	N/A
Theoretical field capacity (ha h ⁻¹)	0.050	0.030	0.027	N/A
Field efficiency, (%)	92.82	45.67	52.32	N/A
Average Plant height (mm)	153	145.67	146.67	148
Cost of weeding (US\$ ha ⁻¹)	5.25	11	12	5

Significantly, the highest field capacity was found using the BO weeder (0.04643 ha h⁻¹), followed by chemical weeding (0.0392 ha h⁻¹), but the field capacities of the BARI push and pull weeder and manual weeding are scored lowest. Singh et al. (2020) found that the power weeder having the higher field capacity (0.075 ha h⁻¹) was the efficient tool for weeding. The almost similar weeding index was found between the BO weeder and the manual weeding method, but a significantly higher weeding index was found in chemical weeding, and the lowest weeding

index was found for the BARI push and pull weeder. These results indicated that more than 90% of weeds were removed by the BO weeder and the manual weeding method, and there was no significant difference between them. Whereas the combination of herbicides intra-row and hoeing inter-row gives on average 99% weed control (plant damage of the BO weeder (0.50%) and manual weeding (0.50%) is found insignificant, but for chemical weeding it was observed to be nil, and little plant damage was found for the BARI push and pull weeder (0.75%). While

Woyessa (2022) found 1.76% plant injuries for the power weeder. There were no significant differences in grain yields among the treatments; similar findings were found by Woyessa (2022). However, the BO weeder showed better performance among the treatments for weeding in the maize field.

Field capacity and field efficiency of maize weeding were 0.046 ha h⁻¹ and 92% for the BO weeder and 0.013 ha h⁻¹ and 47% for the BARI push and pull weeder, respectively. Plant damage ratio was very low, which was less than 1% for the BO weeder. The cutting width was 200 mm, and the depth of cut was 49.3 mm for the BO weeder. The weeding cost per ha of the BO weeder (5 US\$ ha⁻¹) was lower than that of the BARI push and pull weeder (11 US\$ ha⁻¹) and manual

weeding (12 US\$ ha⁻¹) but almost equivalent to chemical weeding (5 US\$ ha⁻¹). Although Woyessa (2022) found that the cost of mechanical weeding was 2% lower than chemical weeding. The performance data of the battery weeder for maize are shown in Table 6.

3.2.2 Chili

Field capacity, weeding index, plant damage, time of weeding, and grain yield in weeding by the BO weeder, BARI push and pull weeder, manual weeding by spade, and chemical weeding methods in chili fields and their coefficient of variance (CV%) as well as least significant difference (LSD) values are shown in Table 7.

Table 7 Field performance of different weeding methods in chili fields

Treatment	Field capacity (ha h ⁻¹)	Weeding index (%)	Plant damage ratio (%)	The yield of chili grain (t ha ⁻¹)
T ₁ (BO weeder)	0.02167 a	95.85 a	2.083 ab	2.653 a
T ₂ (BARI weeder)	0.01233 b	97.53 a	3.125 a	2.318 a
T ₃ (Manual weeding)	0.01133 b	97.81 a	4.167 a	2.165 a
T ₄ (Chemical weeding)	0.01233 b	99.22 a	0.000 b	1.649 a
CV (%)	8.0084	2.453	49.689	25.536
LSD (0.05)	0.00230	4.784	2.326	1.120

Weeding Index (WI) and yield are insignificant among the four practices, but a high weeding index is found in chemical weeding, and the lowest weeding index was found for the BARI push and pull weeder, but the performance of the battery weeder is comparatively acceptable. These results indicated that more than 90% of weeds were removed by the BO weeder and manual weeding method, and there was no significant difference between them. Significantly, the highest field capacity was found in the BO weeder (0.02167 ha h⁻¹), which is unacceptable compared to Tewari et al. (2014), followed by chemical weeding (0.01233 ha h⁻¹) and the BARI push and pull weeder (0.01233 ha h⁻¹), but manual weeding (0.01133 ha h⁻¹) scored lowest, and an insignificant relation was found between them. Though plant damage from chemical weeding was observed to be nil, which was significantly the lowest among the four treatments. Plant damage of the BO weeder (2.083%), which was found to be higher compared to Paul et al. (2025) and manual weeding (4.167%) and the BARI push and pull

weeder (3.125%), was found to be insignificant, but the performance of the BO weeder was comparatively better. There were no significant differences in grain yields among the treatments. But BO weeder showed better performance among the treatments for weeding in the chili field.

Field capacity and field efficiency of weeding in eggplant were 0.0216 ha h⁻¹ and 44.05% for the BO weeder, but the BARI push and pull weeder and manual weeding were 0.0123 ha h⁻¹, 41.70%, and 0.0114 ha h⁻¹, 42.229%, respectively. Plant damage ratio was acceptable but more than 2%. The cutting width was 200 mm, and the depth of cut was 48.3 mm for the BO weeder. The weeding cost per ha of BO weeder (5.25 US\$ ha⁻¹) was lower than that of BARI push and pull weeder (11 US\$ ha⁻¹) and manual weeding (12 US\$ ha⁻¹) but almost equivalent to chemical weeding (5 US\$ ha⁻¹). Except for the chemical weeding cost, the BO weeder is half of the other two practices. The performance data of the BO weeder for chili are shown in Table 8.

Table 8 The performance of the BO weeder for chili compared to other weeding practices

Items	Weeding method			
	Battery weeder	BARI weeder	Manual weeding	Chemical weeding
Row to row distance (cm)	50	50	50	N/A
Number of turns per row	3	4	N/A	N/A
Average Weeding depth (cm)	4.83	1.5	N/A	N/A
Cutting width (mm)	200	150	180	N/A
Average soil penetration (kPa) (10 cm height)	648	648	648	648
Forward speed (km h ⁻¹)	2.5	2	1.5	N/A
Theoretical field capacity (ha h ⁻¹)	0.050	0.030	0.027	N/A
Field efficiency (%)	44.0556	41.708	42.229	N/A
Average Plant height (mm)	118.00	121.67	120.67	121.00
Cost of weeding (US\$ ha ⁻¹)	5.25	11	12	5

3.2.3 Eggplant

Field capacity, weeding index, plant damage, time of weeding, and grain yield in weeding by BO weeder, BARI push and pull weeder, manual weeding by spade, and chemical weeding methods in chili fields and their coefficient of variance (CV%) as well as least significant difference (LSD) values are shown in Table 8. Significantly, the highest field capacity was found in the BO weeder (0.0463 ha h⁻¹), which is acceptable compared to Tewari et al. (2014), followed by chemical weeding (0.0273 ha h⁻¹), but the field capacity of the BARI push and pull weeder and manual weeding are scored lowest. The almost similar weeding index was found between the BO weeder and the BARI push and pull weeder, but a significantly higher weeding index was found in chemical weeding,

and the lowest weeding index was found for manual weeding. Although the range of plant damage for vegetables was found in Tewari et al. (2014) to be from 1.6% to 2.8%, we found plant damage from the BO weeder (2.840%) to be significantly lower than the other four treatments. Plant damage from manual weeding (5.633%), the BARI push and pull weeder (5.893%), and chemical weeding (4.506%) was found insignificant, but the BARI push and pull weeder scored higher. Surprisingly, we found significant differences in grain yields among the treatments. The BO weeders scored the highest, and manual weeding scored the lowest. But the other two practices were found insignificant. The performance of different types of weeding methods for eggplant is shown in Table 9.

Table 9 Field performance of different weeding methods in eggplant fields

Treatment	Field capacity (ha h ⁻¹)	Weeding index (%)	Plant damage ratio (%)	The yield of eggplant grain (t ha ⁻¹)
T ₁ (BO weeder)	0.0463 a	92.79 b	2.840 b	11.63 a
T ₂ (BARI weeder)	0.01067 c	91.62 bc	5.893 a	10.44 ab
T ₃ (Manual weeding)	0.0100 c	88.06 c	5.633 ab	9.83 b
T ₄ (Chemical weeding)	0.0273 b	99.58 a	4.506 ab	10.31 ab
CV (%)	6.889	2.284905	31.39778	7.404359
LSD (0.05)	0.00325	4.246174	2.959786	1.561045

Table 10 Performance of different types of weeding methods for eggplant

Items	Weeding Method			
	BO weeder	BARI weeder	Manual weeding	Chemical weeding
Row-to-row distance (cm)	60	60	60	60
Number of turns per row	3	4	N/A	N/A
Average weeding depth (cm)	4.83	1.5	N/A	N/A
Cutting width (mm)	200	150	180	N/A
Average Soil penetration, kPa (10 cm height)	634	634	634	634
Forward speed (km h ⁻¹)	2.5	2	1.5	N/A
Theoretical field capacity (ha h ⁻¹)	0.050	0.030	0.027	N/A
Field efficiency, (%)	60.63	35.04	37.23	N/A
Average plant height (mm)	77.33	79.33	77.67	76.67
Cost of weeding (US\$ ha ⁻¹)	5.25	11	12	5

The field efficiency of eggplant weeding is 60.63% for the BO weeder, but for the BARI push and pull weeder, it was only 35.04%. The cutting width is 200 mm, and the depth of cutting is 48.3 mm for the BO weeder. The weeding cost per ha of BO weeder (5.25 US\$ ha⁻¹) was lower than that of BARI push and pull weeder (11 US\$ ha⁻¹) and manual weeding (12 US\$ ha⁻¹) but almost equivalent to chemical weeding (5 US\$ ha⁻¹). Except for the chemical weeding cost of the battery, the weeder is half of the other two practices. The performance data of the battery weeder for maize is shown in Table 10.

3.3 Economic analysis

For economic analysis, we need to consider that the

weeder is used for a business purpose that is rental farming. Table 11 illustrates the economic analysis of the BO weeder. The total cost of BO weeder was comparatively lower than that of chemical weeding but higher than that of manual weeding and the BARI push and pull weeder. On the other hand, net return per year is ominously higher than that of the other three practices. The net benefit-cost ratio (BCR) over the total cost of the BO weeder is 1.46, so it is justified and acceptable. On the other hand, the payback period of the BO weeder is 12.98 days or 25.96 ha of land. That means by using 12.98 days or weeding 25.96 ha of land, farmers can get their investment.

Table 11 Economic analysis of BO weeder (US\$)

Cost Parameter	BO weeder	BARI weeder	Chemical weeding	Manual weeding
Fixed cost				
Purchase price of weeder	206	16.5	60	100
Salvage value (5% of Purchase Price of weeder)	10.3	0.825	3	5
Machine life (yr)	5	5	5	2
Depreciation cost per year	39.14	3.135	11.4	47.5
Interest in investment (15%)	30.9	2.475	9	15
Total fixed cost per year	286.34	22.94	83.40	167.50
Total fixed cost per day	0.78	0.06	0.23	0.46
Total fixed cost per ha	0.39	0.03	0.11	0.23
Variable cost				
No of labor / Operator required per day	2	2	2	5
Cost of operator per day	16	16	10	25
Cost of operator per year	800	800	500	1250
Input cost per year (Battery charge, pesticide)	600	0	1450	0
Repair & Maintenance per year	40	30	30	10
Total variable cost per year	1440	830	1980	1260
Total variable cost per day	28.8	16.6	39.6	25.2
Total variable cost per ha	14.4	8.3	19.8	12.6
Total cost per Year	1726.34	852.935	2063.4	1427.5
Total cost per day	34.5268	17.0587	41.268	28.55
Total cost per ha	17.2634	8.52935	20.634	14.275
Return				
Gross Income				
Area covered (ha h ⁻¹)	0.263	0.098	0.223	0.0119
Average area (ha) covered per day (8 h day ⁻¹)	2	1	2	0.095
Total area under weeding per year (ha)	63	24	54	3
Rent per ha (Tk ha ⁻¹)	40	40	40	40
Gross income per year	2520	960	2160	120
Gross income per day	50.4	19.2	43.2	2.4
Gross income per ha	25.2	9.6	21.6	1.2
Net Income				
Net Income over total cost per year	793.66	107.065	96.6	-
Net Income over total cost per day	15.87	2.14	1.93	-
Net Income over total cost per ha	7.93	1.07	0.96	-
Rate of return (BCR)	1.46	1.13	1.05	-
Payback period in day	12.98	7.71	31.06	-
Payback period in ha	25.96	15.41	62.11	-

4 Conclusion

The BO weeder is designed by SolidWorks software and fabricated in view of methodological steps. For performance evaluation of the BO weeder, field trials are done in the Farm Machinery and Postharvest Process Engineering division research field among the BO weeder, the BARI push and pull weeder, manual weeding, and chemical use of weeding. The performance of the BO weeder is found to be quite satisfactory, and it is an excellent weeding technology for farmers. We found a significant difference in the weeding index, time of weeding, and plant damage due to weeding among four weeding methods. And there is no significant difference in yield among the treatments. But BO weeder showed better performance among all treatments. The weeding index of the BO weeder is very close to manual weeding. Effective field capacity and plant damage ratio are acceptable. Though the cost of weeding with a BO weeder is lower than chemical weeding but higher than the other two weeding methods. However, the weeding index, field capacity, and net return were much higher than the other weeding methods. Although interplant weed removal is not possible, it has no significant effect on yield. But multipurpose use of the battery can ensure the sustainability of the BO weeder.

Acknowledgement

The execution of the CRG sub-project has successfully been completed by the Farm Machinery and Postharvest Process Engineering Division, Bangladesh Agricultural Research Institute, using the research grant of the USAID Trust Fund and GoB through the Ministry of Agriculture. We would like to thank the World Bank for arranging the grand fund and supervising the CRGs by BARC. It is worthwhile to mention the cooperation and quick responses of PIU-BARC, NATP 2, in respect of field implementation of the sub-project in multiple sites. Preparing the project completion report required contacting several persons for the collection of information and processing of

research data. Without the help of those persons, the preparation of this document could not have been made possible. All of them, who made it possible, deserve thanks. Our thanks are due to the Director of PIU-BARC, NATP 2, and his team, who gave their wholehearted support to prepare this document. We hope this publication will be helpful to the agricultural scientists of the country for designing their future research projects on technology generation as well as increasing production and productivity for sustainable food and nutrition security in Bangladesh. It would also assist the policymakers of the agricultural sub-sectors in setting their future research directions.

References

- Ahmed, S., V. Kumar, M. Alam, M. R. Dewan, K. A. Bhuiyan, A. A. Miajy, A. Saha, S. Singh, J. Timsina, and T. J. Krupnik. 2021. Integrated weed management in transplanted rice: options for addressing labor constraints and improving farmers' income in Bangladesh. *Weed Technology*, 35(5): 697-709.
- Argüelles, L., and H. March. 2021. Weeds in action: Vegetal political ecology of unwanted plants. *Progress in Human Geography*, 46(1): 44-66.
- Baker, B. P., T. A. Green, and A. J. Loker. 2020. Biological control and integrated pest management in organic and conventional systems. *Biological Control*, 140: 104095.
- BARI (Bangladesh Agricultural Research Institute). 2020. Krishi projukti hatboi (handbook on agro technology). 9th ed. Gazipur, Bangladesh: Bangladesh Agricultural Research Institute.
- Burman, R. R., P. Joshi, J. P. Sharma, N. Sharma, G. S. Mahra, S. Sharma, R. Kumar, R. Singh, V. P. Chahal, and A. K. Singh. 2020. Quantification of drudgery and ergonomics assessment of weeding activity in vegetable production system. *Indian Journal of Agricultural Sciences*, 90(3): 634-638.
- Deb, D. 2020. Is the system of rice intensification (SRI) consonant with agroecology? *Agroecology and Sustainable Food Systems*, 44(10): 1338-1369.
- Hedayatipour, A., M. Goodarzi, and M. Mostafavirad. 2021. Investigation of different mechanical weeding methods performance for weed control efficiency, mechanical injuries and yield in three bean varieties. *CIGR Journal*, 23(1): 128-137.
- Horvath, D. P., S. A. Clay, C. J. Swanton, J. V. Anderson, and W. S. Chao. 2023. Weed-induced crop yield loss: a new

- paradigm and new challenges. *Trends in Plant Science*, 28(5):567-582.
- Hunt, D. 1983. *Farm Power and Machinery Management*. 8th ed. Iowa, USA: Iowa State University Press.
- Hussain, M. I., Z. Abideen, S. Danish, M. A. Asghar, and K. Iqbal. 2021. Integrated weed management for sustainable agriculture. In *Sustainable Agriculture Reviews*, vol. 52, ed. E. Lichtfouse, ch. 11, 367-393. Cham, Switzerland: Springer.
- Jayaseelan, V., R. M. Kumar, and M. MayaKannan. 2020. Design and fabrication of a battery-operated weeder machine. *International Research Journal of Engineering and Technology*, 7(5): 4245-4249.
- Junaid, M. D., and A. F. Gökçe. 2024. Global agricultural losses and their causes. *Bulletin of Biological and Allied Sciences Research*, 9: 66.
- Lavanya, Y., K. Srinivasan, C. R. Chinnamuthu, P. M. Arthanari, S. Shanmugasundaram, and C. N. Chandrasekhar. 2021. Study on effect of weed management practices on weed dynamics and productivity of kharif maize. *The Pharma Innovation*, 10(1): 662-665.
- Liu, C., K. Yang, Y. Chen, H. Gong, X. Feng, Z. Tang, D. Fu, and L. Qi. 2023. Benefits of mechanical weeding for weed control, rice growth characteristics and yield in paddy fields. *Field Crops Research*, 293: 108852.
- Mandal, S. K., B. Bhattacharyya, S. Mukherjee, and P. Chattopadhyay. 2013. Design & development of rotavator blade: Interrogation of CAD method. *International Journal of Scientific Research in knowledge*, 1(10): 439.
- Merfield, C. N. 2022. Redefining weeds for the post-herbicide era. *Weed Research*, 62(4):263-267.
- Paul, S., B. C. Nath, M. D. Huda, M. G. K. Bhuiyan, and H. Paul. 2025. Assessment of mechanical weeders in paddy fields: A study on operational effectiveness in Bangladesh. *Heliyon*, 11(4): e42639.
- Quddus, A., and J. D. Kropp. 2020. Constraints to agricultural production and marketing in the lagging regions of Bangladesh. *Sustainability*, 12(10): 3956.
- Rangasamy, K., M. Balasubramanian, and K. R. Swaminathan. 1993. Evaluation of power weeder performance. *Agricultural Mechanization in Asia, Africa & Latin America* 24(4):16-18.
- Rao, A. N., R. G. Singh, G. Mahajan, and S. P. Wani. 2020. Weed research issues, challenges, and opportunities in India. *Crop Protection*, 134: 104451.
- Singh, S., D. Padhee, S. Sonwani, and T. Sahu. 2020. Design, Fabrication and Evaluation of Wheel Operated Sprayer. *International Journal of Current Microbiology and Applied Sciences*, 9(1): 1649-1659.
- Singh, Y., V. P. Singh, B. Chauhan, A. Orr, A. M. Mortimer, D. E. Johnson, and B. Hardy. 2008. Direct seeding of rice and weed management in the irrigated rice-wheat cropping system of the Indo-Gangetic Plains. Los Baños, Philippines: International Rice Research Institute; Pantnagar, India: Directorate of Experiment Station, G.B. Pant University of Agriculture and Technology.
- Tewari, V. K., C. N. Singh, K. P. Vidhu, and H. Tripathi. 2014. Performance evaluation and scope of adoption of rotary power weeder in vegetable crops. *Agricultural Engineering Today*, 38(3):10-14.
- Varani, M., and M. Mattetti. 2023. Rotary ripper: A possible solution to increase the efficiency of tillage operations. *Agronomy*, 13(2): 365.
- Woyessa, D. 2022. Weed control methods used in agriculture. *American Journal of Life Science and Innovation*, 1(1): 19-26.
- Yang, Y., Z. Hu, F. Gu, and Q. Ding. 2023. Simulation and experimental study of the tillage mechanism for the optimal design of wheat rotary strip-tiller blades. *Agriculture*, 13(3): 632.